

the better way to heat

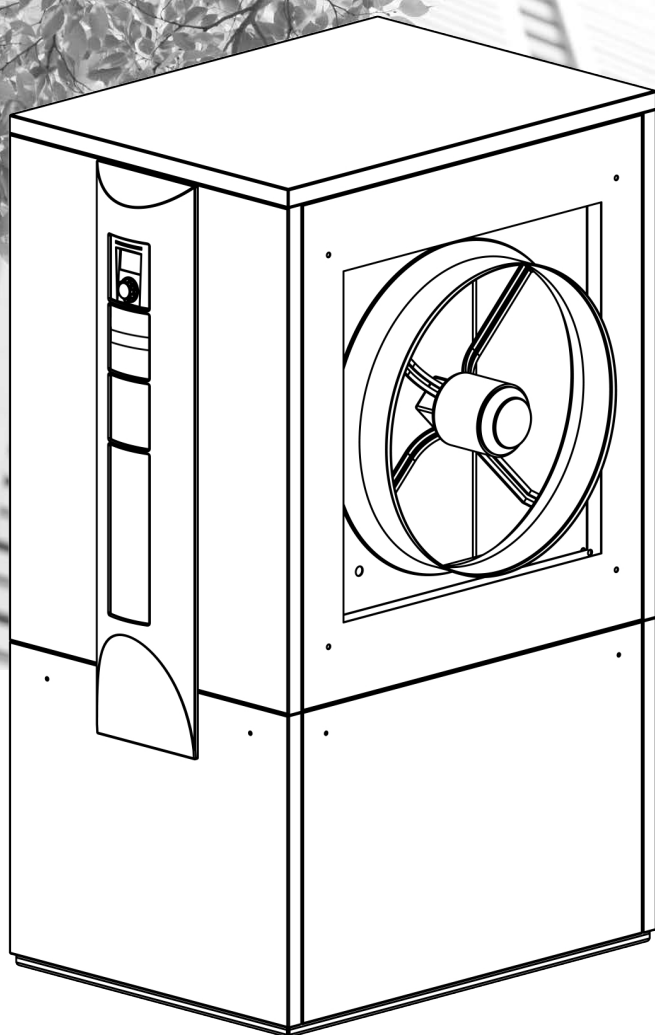

Air/Water Heat Pumps
Indoor installation

Operating Manual

LW 140(L) – LW 251(L)





1 Please read first

This operating manual provides important information on the handling of the unit. It is an integral part of the product and must be stored so that it is accessible in the immediate vicinity of the unit. It must remain available throughout the entire service life of the unit. It must be handed over to subsequent owners or operators of the unit.

Read the operating manual before working on or operating the unit. This applies in particular to the chapter on safety. Always follow all instructions completely and without restrictions.

It is possible that this operating manual may contain instructions that seem incomprehensible or unclear. In case of questions or uncertainty, contact the factory customer service department or the manufacturer's local service partner.

Since this operating manual was written for several different models of the unit, always comply with the parameters for the respective model.

This operating manual is intended only for persons assigned to work on or operate the unit. Treat all constituent parts confidentially. The information contained herein is protected by copyright. No part of this information may be reproduced, transmitted, copied, stored in electronic data systems or translated into another language, either wholly or in part, without the express written permission of the manufacturer.

2 Symbols

The following symbols are used in the operating manual. They have the following meaning:



Information for users.



Information or instructions for qualified technicians.



DANGER

Indicates a direct impending danger resulting in severe injuries or death.



WARNING

Indicates a possibly dangerous situation that could result in severe injuries or death.



CAUTION

Indicates a possibly dangerous situation that could result in medium or light injuries.



IMPORTANT

Indicates a possibly dangerous situation, which could result in property damage.



NOTE

Emphasized information.



Prerequisite for an action.



Single-step instruction for action.

1., 2., 3., ... Numbered step within a multi-step instruction for action. Adhere to the given sequence.



List.



Reference to further information elsewhere in the operating manual or in another document.



ENERGY SAVING TIP

Indicates suggestions that help to save energy, raw materials and costs.



Contents

1	Please read first	2
2	Symbols	2
3	Intended use	4
4	Disclaimer	4
5	EC conformity	4
6	Safety and Security	4
7	Contact	6
8	Warranty/Guarantee	6
9	Waste disposal	6
10	Operating principle of heat pumps	6
11	Area of utilisation	6
12	Heat quantity recording	7
13	Operation	7
14	Care of the unit	7
15	Scope of delivery	8
16	Transport, installation, assembly	8
16.1	Installation location	9
16.2	Transport to installation location	9
16.3	Installation	12
16.4	Mounting the air ducts	12
16.5	Installation / connection to heating circuit	16
16.6	Condensate discharge	16
17	Pressure relief	17
18	Overflow valve	17
19	Buffer tank	17
20	Circulating pumps	17
21	Water heating	17
22	Hot-water tank	17
23	Electrical connections	18
24	Rinsing, filling and bleeding the system	19
25	Insulating the hydraulic connections	20
26	Installation of the control element	20
27	Installation and removal of the screen	21
28	Set the overflow valve	22
29	Commissioning	23
30	Maintenance of the unit	23
30.1	Annual maintenance	24
30.2	Cleaning and rinsing of unit components	24
31	Malfunctions	24
31.1	Unlock the safety temperature limiter	24
32	Dismantling	25
32.1	Removal of the buffer battery	25
	Technical data/scope of delivery	26
	Performance curves	28
	LW 140(L)	28
	LW 180(L)	29
	LW 251(L)	30
	Dimensional drawings	31
	LW 140 – LW 180	31
	LW 140L – LW 180L	32
	LW 251	33
	LW 251L	34
	Installation plans	35
	LW 140(L) – LW 180(L)	
	Installation plan version 1	35
	Installation plan version 2	36
	Installation plan version 3	37
	Installation plan version 4	38
	LW 251(L)	
	Installation plan version 1	39
	Installation plan version 2	40
	Installation plan version 3	41
	Installation plan version 4	42
	LW 140(L) – LW 251(L)	
	Coastal installation	43
	Hydraulic integration	44
	LW 140(L) – LW 251(L)	
	Row tank	44
	Separate buffer tank	45
	Legend Hydraulic integration	46
	Terminal diagram	47
	LW 140(L) – LW 251(L)	47
	Circuit diagrams	48
	LW 140(L)	48
	LW 180(L)	51
	LW 251(L)	54
	EC declaration of conformity	59



3 Intended use

The unit may be used only for the intended purpose. That means:

- for heating.
- for heating hot water.

The unit may be operated only within its technical parameters.

→ "Technical data/scope of delivery", from page 26



NOTE

Notify the responsible power supply company of the use of a heat pump or heat pump system.



CAUTION

The unit is not suitable for use in IT network systems.

4 Disclaimer

The manufacturer will not be liable for damage resulting from unauthorized use of the unit.

The manufacturer's liability will also be voided in the following cases:

- if work is performed on the unit and its components in a manner that does not comply with the terms of this operating manual;
- if work is performed on the unit and its components in an improper manner;
- if work is performed on the unit that is not described in this operating manual, and this work was not expressly approved in writing by the manufacturer;
- if the unit or components in the unit are modified, redesigned or removed without the express written permission of the manufacturer.

5 EC conformity

The unit bears the CE mark of conformity.

→ "EC declaration of conformity", page 59

6 Safety and Security

The unit is safe to operate when used for its intended purpose. The construction and design of the unit conform to current state-of-the-art standards, all relevant DIN/VDE regulations and all relevant safety regulations.

The operating manuals supplied with the product are intended for all users of the product.

The operation of the product via the heating and heat pump control and work on the product which is intended for end customers / operators is suitable for all age groups of persons who are able to understand the activities and the resulting consequences and can carry out the necessary activities.

Children and adults who are not experienced in handling the product and do not understand the necessary activities and the resulting consequences must be instructed and, if necessary, supervised by persons experienced in handling the product and who are responsible for safety.

Children must not play with the product.

The product may only be opened by qualified personnel.

All instructional information in this operating manual is solely directed at qualified, skilled personnel.

Only qualified, skilled personnel is able to carry out the work on the unit safely and correctly. Interference by unqualified personnel can cause life-threatening injuries and damage to property.

- ▶ Ensure that the personnel is familiar with the local regulations, especially those on safe and hazard-aware working.
- ▶ Only allow qualified personnel with "electrical" training to carry out work on the electrics and electronics.
- ▶ Only allow qualified, skilled personnel to do any other work on the system, e.g.
 - Heating installer
 - Plumbing installer
 - Refrigeration system installer (maintenance work)

Every person who carries out work on the unit must comply with the applicable accident prevention and safety regulations. This applies in particular to the wearing of personal protective clothing.

During the warranty and guarantee period, service work and repairs may only be carried out by personnel authorised by the manufacturer.



DANGER

Danger of fatal injury due to electric current!

Electrical connections may be installed only by qualified electricians.

Before opening the unit, disconnect the system from the power supply and secure it from being switched back on!

Existing earthing connections within housings or on mounting plates must not be altered. If this should nevertheless be necessary in the course of repair or assembly work:

- ▶ Restore earthing connections to their original condition after completion of the work.



IMPORTANT

If using the unit in 3~230V systems, please note that the residual-current circuit breaker (RCCB) used must be AC-DC sensitive.



WARNING

Observe safety labels on and in the unit.



WARNING

Unit contains refrigerants!

Leaking refrigerant could result in personal injury or material damage. Therefore:

- Shut down unit.
- Notify the manufacturer's authorized service center.



IMPORTANT

For safety reasons:

Never disconnect the unit from the power supply, unless the unit is being opened.



IMPORTANT

Install the heat pump only indoors and operate only with outside air as the heat source. The air ducts must discharge into the open air. Do not restrict or block the air ducts.

- "Dimensional drawings", from page 31, and "Installation plans", from page 35, for respective unit model



WARNING

Switch on unit only if air ducts are mounted on the unit.

Take measures on the fan side to prevent injuries from the rotating fan (above-ground air duct discharge: below-ground air-channel discharge: wire mesh grille – accessories not included in scope of delivery).



IMPORTANT

The integration of the heat pump in ventilation systems is not permissible. The use of the cooled air for cooling purposes is not permitted.



IMPORTANT

The ambient air in the location where the heating pump is installed and also the intake air which is used as a source of heat must not contain any kind of corrosive components! Components such as ammonia, sulphur, chlorine, salt, sewer gas, flue gases etc. may cause damage leading to complete failure or even a total write-off of the heating pump!



WARNING

In the air outlet area the air temperature is ca. 5K below the ambient temperature. Under certain climatic conditions, therefore, an ice layer can form in the air outlet area. Install the heat pump so that the air blower does not blow in the direction of footpaths.

Decommissioning / draining the heating

If the system/heat pump is decommissioned or drained after already being filled, it must be ensured that the condenser and any heat exchangers have been drained completely in the event of freezing temperatures. Residual water in heat exchangers and condensers can result in damage to the components.

1. Completely drain the system and the condenser, and open vent valves.
2. Blow them clear with compressed air, if required.



7 Contact

Addresses for purchasing accessories, for servicing or for answers to questions about the unit and this operating manual can be found on the internet and are kept up-to-date:

- Germany: www.alpha-innotec.de
- EU: www.alpha-innotec.com

8 Warranty/Guarantee

For warranty and guarantee conditions, please refer to the purchase documents.



NOTE

Please contact your dealer concerning warranties and guarantees.

9 Waste disposal

When decommissioning the unit, always comply with applicable laws, directives and standards for the recovery, recycling and disposal of materials and components of cooling units.

→ "32 Dismantling", page 25

10 Operating principle of heat pumps

Heat pumps operate on the principle of a refrigerator: the same technology, only with the opposite effect. The refrigerator extracts heat from foods, which is released into the room through fins on the back.

The heat pump extracts heat from our environment: air, earth or ground water. The extracted heat is conditioned in the unit and supplied to the heating water. Even when it is extremely cold outside, the heat pump draws enough heat to heat a house.

Example: drawing of a brine/water heat pump with floor heating:

ca. 3/4

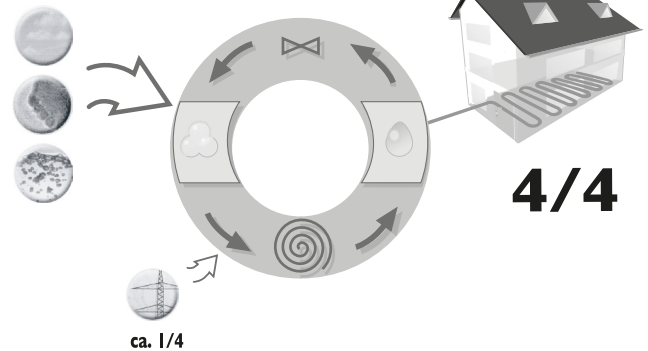

$\frac{4}{4}$ = usable energy
 approx. $\frac{3}{4}$ = environmental energy
 approx. $\frac{1}{4}$ = external electrical energy

11 Area of utilisation

Taking into consideration the ambient conditions, limits of application and the applicable regulations, every heat pump can be utilized in new or existing heating systems.

→ "Technical data/scope of delivery", from page 26



12 Heat quantity recording

In addition to the proof of the unit's efficiency, EE-WaermeG also meets the demand for a heat quantity recording (hereafter referred to as HQR). The HQR is mandatory with air/water heat pumps. With brine/ water and water/water heat pumps, a HQR may only be set up when a forward flow temperature of $\geq 35^\circ\text{C}$ has been reached. The HQR must record the total warm energy release (heating and hot water) in the building. In heat pumps with heat quantity recording, the analysis is conducted by the regulator. The regulator displays the thermal energy that is exchanged from the heating system in kWh.

13 Operation

Your decision to purchase a heat pump or a heat pump system is a long-term contribution to protecting the environment through low emissions and reduced primary energy use.

You can operate and control the heat pump system with the control element of the heating and heat pump regulator.



NOTE

Make sure that the control settings are correct.

→ Operating manual of the heating and heat pump regulator

To ensure that your heat pump or heat pump system operates efficiently and ecologically, the following are especially important:



ENERGY SAVING TIP

Avoid unnecessarily high flow temperatures. A lower flow temperature on the hot water side increases the efficiency of the system.



ENERGY SAVING TIP

When letting in fresh air, do not leave windows open for an extended period in order to save energy and reduce your heating costs.

14 Care of the unit

The outer surfaces of the unit can be cleaned with a damp cloth and household cleaning products.

Do not use cleaning or care products that contain abrasives, acids and/or chlorine. Such products would destroy the surfaces and could also damage the technical components of the unit.



15 Scope of delivery

Example of scope of delivery:

View 1:



View 2:



Unit with a completely hermetically enclosed compressor, all safety-related components for monitoring of the cooling circuit, integrated heating and heat pump regulator, sensors mounted in the unit for the monitoring of hot gas, heating water forward flow and return flow temperatures, as well as a hose for condensate discharge (connected to heat pump side)

1. Inspect delivery for outwardly visible signs of damage.
2. Check to make sure that delivery is complete. Any defects or incorrect deliveries must be claimed immediately.



NOTE

Note the model. Check the air blow-out direction of the unit.

- Units with the abbreviation L in the model designation blow the air out to the left (when viewed from the control side).

→ "Technical data/scope of delivery", from page 26

Accessories necessary for operation



IMPORTANT

Use only original accessories from the manufacturer of the unit.

Air ducts (with air duct accessories) must be ordered separately.

Additional accessories

You must order separately:

- installation accessories (vibration decouplers) for air/water indoor installation heat pumps
- air / magnetic sludge separator

16 Transport, installation, assembly

Observe the following when performing all work:



NOTE

Always comply with applicable accident prevention regulations, statutory regulations, ordinances and directives.



NOTE

Observe the sound levels of the respective model.

→ "Technical data/scope of delivery", from page 26, "Sound" section



16.1 Installation location

! IMPORTANT
Install the unit only indoors.

Installation room and space requirements

i NOTE
Note and follow the local regulations and standards regarding the installation room and space requirements. The table shows the regulations according to EN 378-1 relevant in Germany.

Refrigerant	Limit value [kg/m ³]
R 134a	0.25
R 404A	0.52
R 407C	0.31
R 410A	0.44
R 448A	0.39

→ "Technical data/scope of delivery", from page 26

$$\text{Minimum room volume} = \frac{\text{Refrigerant capacity [kg]}}{\text{Limit value [kg/m}^3\text{]}}$$

i NOTE
If several heat pumps of the same type are installed, only one heat pump need to be taken into account. If several heat pumps of different types are installed, only the heat pump with the largest refrigerant volume needs to be taken into account.

- ✓ Minimum volume corresponds to the requirements for the refrigerant used.
- ✓ Installation inside the building only.
- ✓ Installation room is dry and frost-free.
- ✓ Clearance dimensions are met
- "Dimensional drawings", from page 31, and "Installation plans", from page 35, for respective unit model

i NOTE
The noise emissions of the heat pumps must be taken into account in the respective installation plans for air/water heat pumps. The respective regional regulations must be observed.

- ✓ The surface/floor is suitable for installation of the unit:
 - level and horizontal foundation
 - load-bearing capacity for the unit's weight

16.2 Transport to installation location

To prevent damage during transport, always transport the unit to final installation location in its original packaging, using a lifting truck.

i NOTE
You can underpin the LW 251(L) using a lifting truck; transport the other units on the wooden pallet.

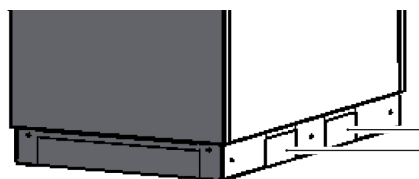

LW 251(L)

If it is not possible to transport the unit to the final installation location using a lifting truck, you can also transport the heat pumps using a hand truck (not applicable for the LW 251(L)).

→ "Lifting the unit with pipes", from page 10

! DANGER
Several people are required to transport the unit. Do not underestimate the weight of the unit.

→ "Technical data/scope of delivery", from page 26, "General unit data" section

! DANGER
The unit is not fastened to the wooden pallet!. Danger of tipping over during transport! This can result in personal injury and damage to the unit.
▶ Take suitable precautionary measures to eliminate the danger of tipping.

! IMPORTANT
Never use components and hydraulic connections on the unit for purposes of transport.

! IMPORTANT
Do not damage the hydraulic connections under any circumstances.

! IMPORTANT
Do not tilt the unit more than a maximum of 45° (in any direction).



Lifting the unit with pipes (not possible with the LW 251(L))

The LW 140(L) and LW 180(L) units can be lifted with $\frac{3}{4}$ " and/or 1" pipes (provided by customer) that are suitable for the weight of the respective unit. Special holes are provided in the frame for this purpose.

1. Remove lower facing panels on the switch box side (= operator side) side of the unit. To do so, loosen quick-release screws. Turn counter-clockwise 90° .

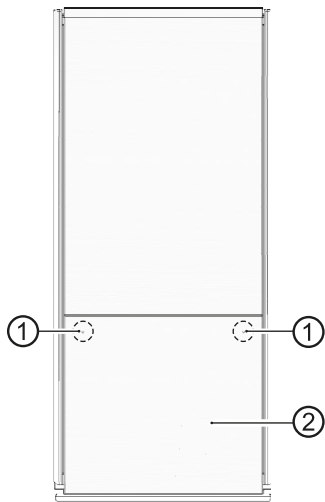

- 1 Quick-release screws
- 2 Lower facing panel

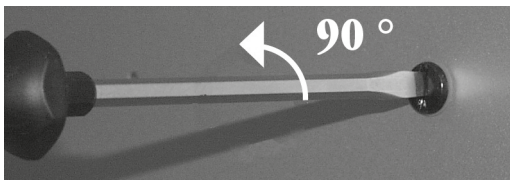

2. Pull lower facing panel upwards and outwards, detach and set securely to the side.



3. On the back of the unit, remove the sealing grommet.

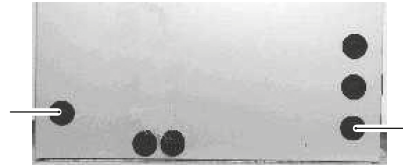

4. Insert the pipes through the holes in the frame on the switch box side (= operator side).

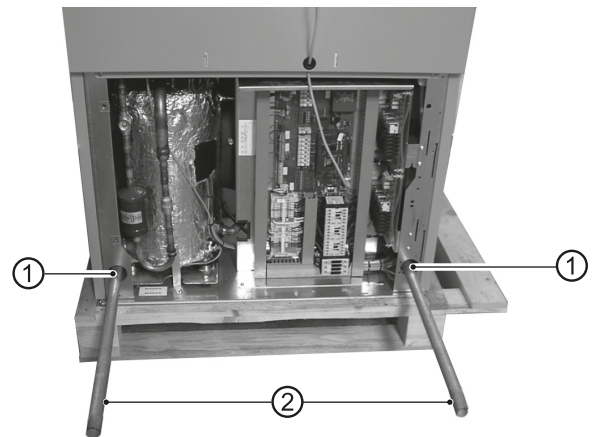

- 1 Holes in the frame
- 2 Inserted pipes

Make sure that pipes do not damage cable assemblies and components in the unit. Guide pipes carefully past cable assemblies and components in the unit.

5. Guide pipes through the marked openings on the back side of the unit.

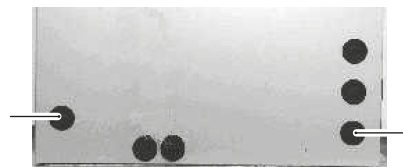

6. Lift the unit on the pipes with at least four people and carry it to its final installation location.
7. Put the unit in its final installation location. Make sure that the frame of the unit is in full contact with the underlying surface.
8. Remove the pipes and re-place the sealing grommets on the back side of the unit.
9. If the electrical connections will not be carried out directly thereafter, mount the lower facing panel on the operating side.



Retractable ventilator

In order to allow the unit to be easily transported through tight cellar spaces and narrow doorways and/or hallways, the ventilator retracts approx. 10 cm into the body of the unit.

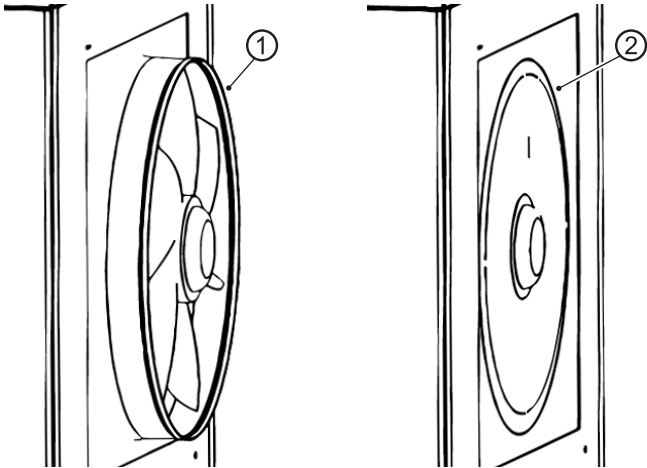

- 1 Fan in delivery condition
- 2 Fan pushed into the unit

! IMPORTANT

Only retract the ventilator into the body of the unit for transport purposes and extend it to its original positions following transport.

1. Remove lower facing panels on the fan side of the unit. To do so, loosen quick-release screws. Turn counter-clockwise 90°.

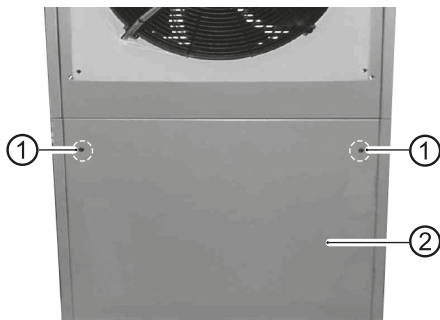

- 1 Quick-release screws
- 2 Lower facing panel

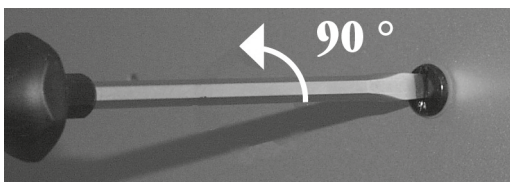

2. Pull lower facing panel upwards and outwards, detach and set securely to the side.



3. Remove the screws located on the lower side of the upper facing panel.



4. Slant the facing panel upwards, remove and set aside in a safe place.

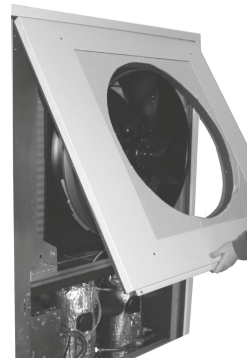

Then remove side facing panels from the unit too and store safely.

5. At the fan, thread the two guide rods supplied through the metal tab and fan.

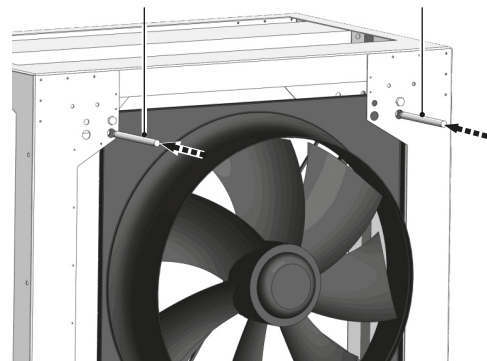



Then, on both sides, hook the guide rods in the keyhole slot pattern of the upper metal tab inside the unit.

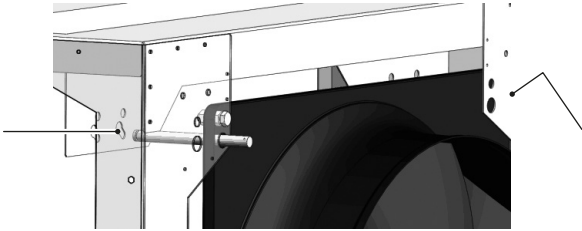

6. On the inside of the device, undo all four nuts (M12) of the fan's connections and remove together with the spring washers.

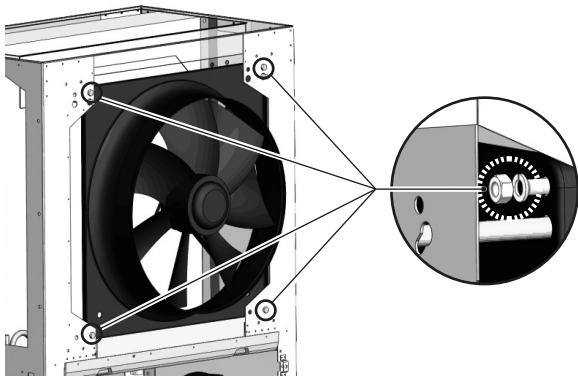

7. Push the fan in the direction of the evaporator up to the top metal tab inside the unit.

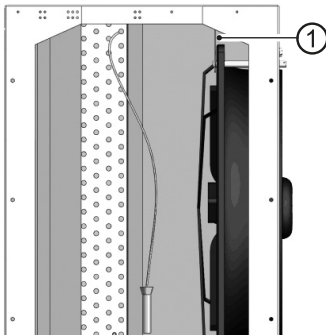

1 top metal tab inside the unit

8. Push the screws M12 x 40 (2x) supplied through the fan and the top metal tab and secure with nuts M12.

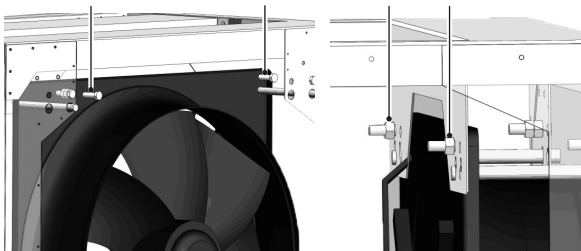

9. Lower the unit at the installation location. Make sure that the frame of the unit is in full contact with the underlying surface and the unit is positioned horizontally.
Undo the mounting nuts at the top metal tab and remove the corresponding screws.
Then pull the fan out of the unit and screw tightly back onto the unit frame (do not forget the spring washers).
10. Remove guide rods and attach all facing panels back onto the unit.

16.3 Installation

Set the unit on a stable, solid and level, preferably sound-insulated surface. Make sure that the foundation is designed for the weight of the heat pump.



CAUTION

In the air outlet area the air temperature is ca. 5K below the ambient temperature. Under certain climatic conditions, therefore, an ice layer can form in the air outlet area. Install the heat pump so that the air blower does not blow in the direction of footpaths.



IMPORTANT

Do not tilt the unit more than a maximum of 45° (in any direction).



NOTE

Always observe the installation plan for the respective model. Note the size and minimum clearances.

→ "Installation plans", from page 35, for respective unit model

Set up the unit so that the switch box side (= operating side) is accessible at all times.

16.4 Mounting the air ducts



NOTE

Note the air blow-out direction of the unit.

- Units with the abbreviation L in the model designation blow the air out to the left (when viewed from the control side).



IMPORTANT

Use only original accessories or air ducts recommended by the manufacturer (fibre-glass lightweight concrete ducts).

Mount air ducts only according to the installation plan for the respective unit.

→ "Installation plans", from page 35, for respective unit model



Wall duct(s) assembly

1. Remove the parts necessary for the assembly of the wall duct(s) from their respective boxes.

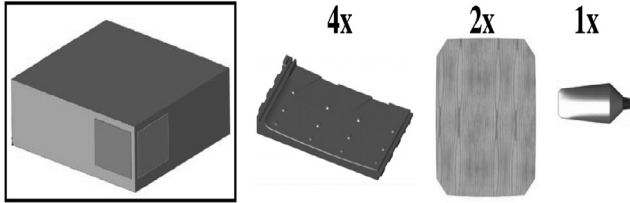

2. Next, interlock the 2 pieces of the wall duct(s) that belong together, as illustrated in the following drawing. Use the lubricant supplied upon delivery to help in this process.

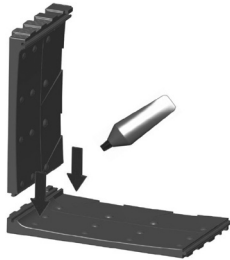

3. Affix an additional part as illustrated.

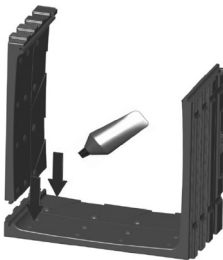

4. Rotate the already-interlocked parts 90° and affix the final piece at the bottom.

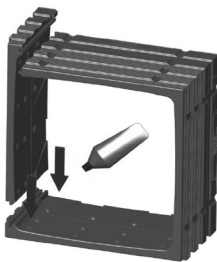

5. Rotate the already-interlocked parts by 90° once again and set up the final connection.

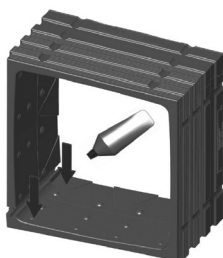

6. Stabilise the wall duct from the inside using the chipboard included with delivery.

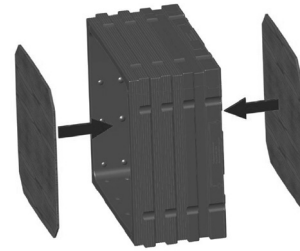

7. Install the wall duct in the masonry **from the house exterior**. This can either be done during the construction phase (by means of sealing).



NOTE

Mount the wall ducts 1 cm above the finished outer facade.

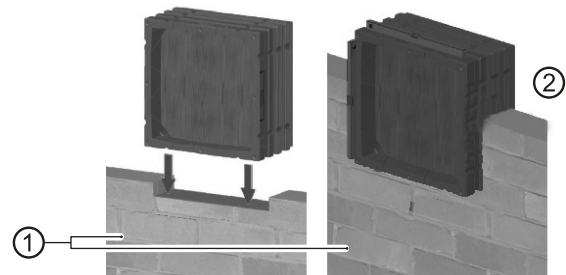

- 1 Masonry of the house exterior
- 2 Insert the wall duct in the masonry (1 cm above the finished outer facade)

or retrofit (using foam in the masonry):

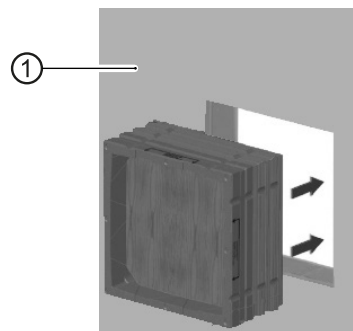

- 1 Finished outer facade



NOTE

Wall ducts fix wall openings, help avoid cold air transmission in the masonry as well as assist in the assembly of weather / rain guards and wire mesh grilles



Air ducts assembly

1. Remove the parts necessary for the assembly of the air duct(s) from their respective boxes.

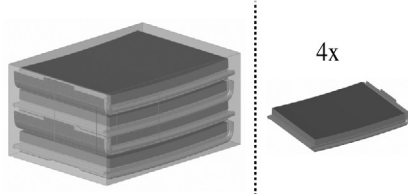

2. The interlocking of the air ducts is carried out as described in the section 2 – 5 entitled "Wall duct(s) assembly".

! IMPORTANT

The height difference between the vertical centre of the air duct connections on the unit and the top edge of the air inlet / air outlet on the building must not exceed 2 m.

Securing the air duct into the wall duct

1. Pull the roll seal included with delivery over the end of the air duct.
2. Push this end of the air duct into the wall duct.

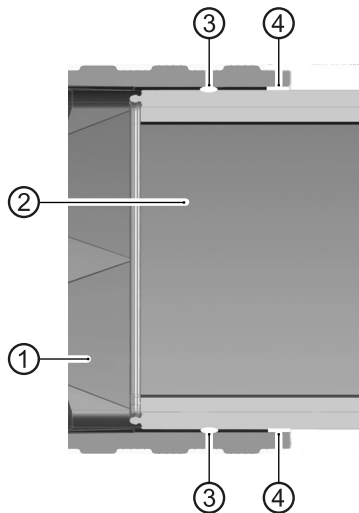

- 1 Wall duct
- 2 Air duct
- 3 Roll seal
- 4 Bentonite waterproofing tape (apply only after assembling the unit's connection fastener)



NOTE

After the other end of the air duct has been secured to the heat pump, close the opening between the wall duct and the air duct using the bentonite waterstop tape included with delivery.

Securing the air duct on the heat pump

1. Clip on the assembly rail and secure it using special screws to the spots on the air duct designated as the air intake side.
2. Stick the adapter base included with delivery on the edge of the air duct.
3. Position the air duct on the respective opening of the air intake side.
4. Hook the 4 tension springs included with delivery into the holes provided for them on the air intake side of heat pump.
5. Hook the tension springs into the assembly tail that has been screwed on to the air duct.
6. Secure a protective cap over the assembly rail.

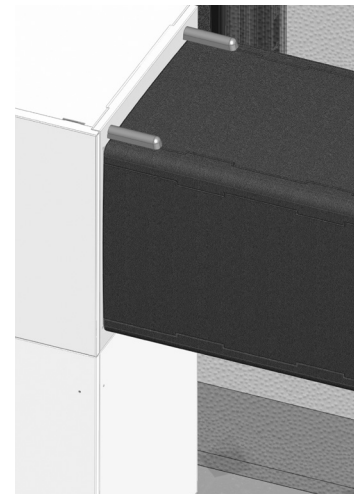

7. Repeat ① – ⑥ the process on the air output side.



NOTE

Don't forget:
After the air ducts have been secured to the heat pump, close the opening between the wall duct and the air duct using the bentonite waterstop tape included with delivery.



NOTE

Secure the air ducts to the cover using appropriate measures.



Screen frame assembly

Screw the screen frame to the wall ducts on both the air intake and output sides.

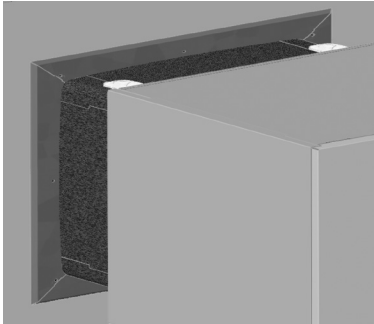

NOTE

The screen frame has no function, it is included solely to provide an optically attractive transition to the wall duct.

Wire mesh grille and weather/rain guards assembly

1. Remove the wire mesh grille and the weather / rain guards as well as the assembly frame and fastening material from their respective boxes.

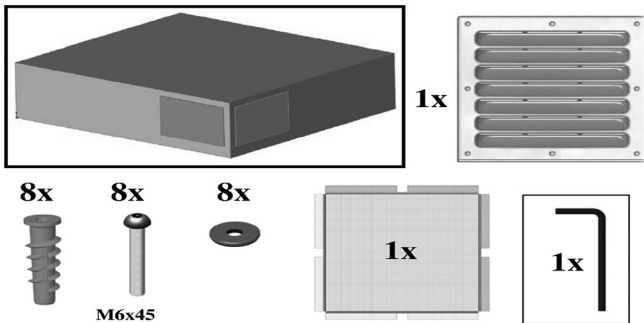

2. From the outside of the house inwards, insert the assembly frame into the wall duct on the air intake side and secure with screws.

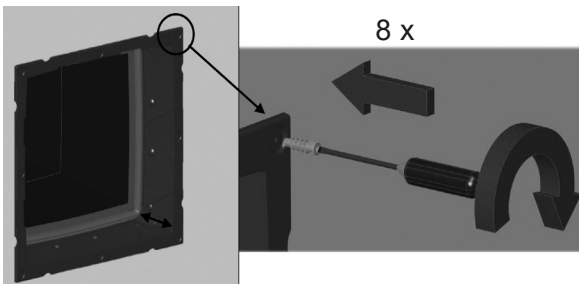

3. Position the wire mesh grille in the assembly frame.

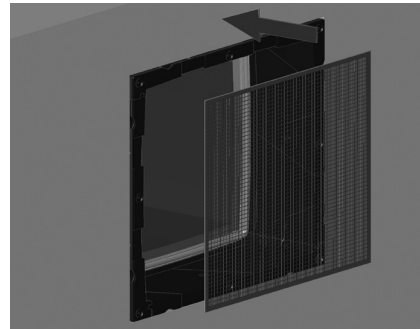

4. Set the weather / rain guards on the assembly frame in the wall duct and screw down.

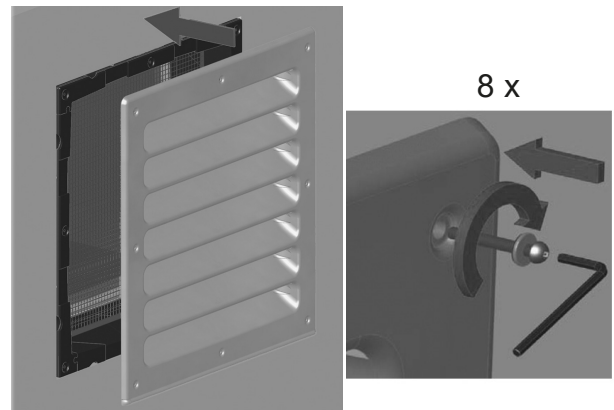

NOTE

If the wall duct is positioned above ground level, attach the weather guard.
If the wall duct is positioned in a light well (below ground level), attach the rain guard.

5. Repeat 2 – 4 the process on the air output side.



16.5 Installation / connection to heating circuit

! IMPORTANT

Connect the unit to the heating circuit according to the hydraulic diagram for the respective model.

→ Hydraulic connection" instructions

i NOTE

Check to make sure that the diameters and lengths of the pipes for the heating circuit are sufficiently dimensioned.

i NOTE

Circulating pumps must be multi-stage, regulated pumps. They must be able to deliver at least the minimum hot water flow rate required for your model.

→ "Technical data/scope of delivery", from page 26, "heating circuit" section

! IMPORTANT

The hydraulic system must be equipped with a buffer tank, the required volume of which depends on the model of your unit.

→ "Technical data/scope of delivery", from page 26, "heating circuit, buffer tank" section

! IMPORTANT

Dirt and deposits in the (existing) hydraulic system can cause damage to the heat pump.

▶ Ensure that a sludge separator is installed in the hydraulic system.

▶ Rinse the hydraulic system thoroughly prior to establishing the hydraulic connection of the heat pump.

! IMPORTANT

When installing the connections, always secure the connections on the unit from twisting, in order to prevent damage to the copper pipes in the interior of the unit.

1. Install shut-off devices for the hot water outflow (forward flow) and hot water inflow (return flow) on the heat pump side.

i NOTE

During installation of the shut-off devices, the liquefier of the heat pump can be rinsed, if necessary.

2. Connect the unit to the pipes of the heating circuit via vibration decouplers. They must be installed in order to prevent damage from vibrations to the pipes.

i NOTE

If an existing system is being replaced, the old vibration decoupling may not be reused. Vibration decouplers are available as accessories.

The connections for the heating water outflow (forward flow) and the hot water inflow *(return flow) are marked accordingly.

→ For positioning of the connections: "Dimensional drawings", from page 31, for the respective model

16.6 Condensate discharge

The condensation water that accumulated from the air must be drained via the pre-mounted hose in the unit for condensate discharge. To do so, connect the hose for condensate discharge with a water drain.

→ For positioning of the connection for condensate discharge: "Dimensional drawings", from page 31, for the respective model

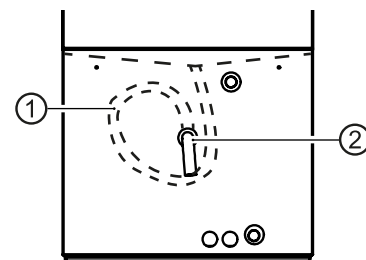

- 1 Hose for condensate discharge in interior of unit
- 2 Connection for the condensate discharge on the outside of the unit



! IMPORTANT

Guide the pre-mounted hose in the unit for condensate discharge in the interior of the unit as a siphon, as shown in the illustration.

Discharge of the condensate into the sewage system is permitted only via a funnel siphon, which must be accessible at all times.

17 Pressure relief

Equip the heating circuit in accordance with local standards and directives with a safety valve and an expansion tank.

Also install filling and emptying devices, shut-off devices and non-return valves in the heating circuit.

18 Overflow valve

Use an overflow valve for tanks integrated in series to ensure the minimum flow rate of the heating circuit volume flow through the heat pump. The overflow valve must be dimensioned so that the minimum flow rate of the volume flow through the heat pump is ensured when the heating circuit is shut off.

→ "28 Set the overflow valve", page 22

19 Buffer tank

The hydraulic connection of the heat pump requires a buffer tank in the heating circuit. It ensures a minimum operating time of the heat pump when the heating circuit valves are closed. The required volume of the buffer tank is calculated based on the following formula:

$$V_{\text{Buffer tank}} = \frac{\text{minimum flow rate of heat circuit volume flow / hour}}{10}$$

→ For the minimum flow rate of the heat circuit volume flow: "Technical data/scope of delivery", from page 26, "Heating circuit" section

In mono-energetic air/water systems, integrate the buffer tank in the heating water outflow (forward flow) before the overflow valve.

20 Circulating pumps

! IMPORTANT

Always note the model.

Do not use regulated circulating pumps.

Circulating pumps and domestic hot water circulation pumps must be multi-stage pumps.

21 Water heating

Water heating with the heat pump requires an additional hot water circuit, parallel to the heating circuit. Make sure that the heating water charge is not channeled through the buffer tank of the heating circuit.

→ "Hydraulic connection" instructions

22 Hot-water tank

If the heat pump will be used for heating hot water, you must integrate special hot-water tanks in the heat pump system. The storage volume must be sufficient so that the required hot water quantity is available even during a power outage.

i NOTE

The heat exchanger surface of the hot water tank must be dimensioned so that the heating capacity of the heat pump is transferred with minimal spreading.

We offer a variety of hot-water tanks for you to choose from. They are optimized for use with your heat pump.

i NOTE

Integrate the hot-water tank in the heat pump system corresponding to the hydraulic diagram for your system.

→ "Hydraulic connection" instructions



23 Electrical connections

Observe the following when performing all work:



DANGER

Danger of fatal injury due to electric current!

Electrical connections may be installed only by qualified electricians.

Before opening the unit, disconnect the system from the power supply and secure it from being switched back on!



DANGER

Observe the relevant EN-, VDE and/or applicable local safety regulations during the installation and during all electrical work.

Comply with technical connection requirements of the responsible power supply company (if required by the latter)!



NOTE

All live wires must be stripped before they are installed in the cable duct of the switch boxes!

Power connection

1. If the unit is closed, open the facing panels on the operating side.
→ "Lifting the unit with pipes", page 10, point 1
2. Open electrical switch box of unit.

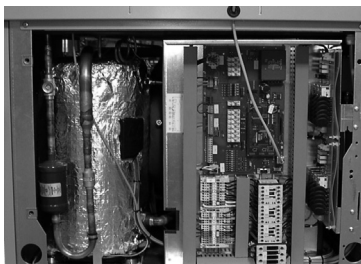

Example of open electrical switch box

3. Lead 230V power cable, power cable for circulating pumps and cable for external temperature sensor through the rubber sockets on the facing panel in the unit.

- 3.1. Cut out the rubber sockets on the facing panel.

→ For positioning of the rubber sockets for inserting the wires: "Dimensional drawings", from page 31, for the respective model

- 3.2. Insert the cables through the rubber sockets in the unit.

The wires inside the unit are guided in a closed wire duct to the terminals on the switch plate.

4. Install electric connections according to the terminal diagram that applies to your model.

→ "Terminal diagram", page 47



IMPORTANT

Ensure clockwise rotary field of the load power supply (compressor).

- An incorrect rotary field of the compressor during operation can cause serious, irreparable damage to the compressor.



IMPORTANT

The power supply for the heat pump must be equipped with an all-pole miniature circuit-breaker with at least 3 mm contact spacing to IEC 60947-2.

Residual current circuit breaker type A is sufficient.

→ "Technical data/scope of delivery", from page 26, "Electric" section.



IMPORTANT

If using the unit in 3~230V systems, please note that the residual-current circuit breaker (RCCB) used must be AC-DC sensitive.



NOTE

Factory setting for the electric heating element in units with integrated electric heating elements is 6 kW (9 kW). It can be changed at contactor Q5 (Q6) for 2 kW (3 kW) or 4 kW (6 kW).



→ For further information, see the adhesive label on the electric heating element



NOTE

The control element of the heat and heat pump regulator can be connection with a computer or network using a network cable designed for such purposes, thus allowing the heating and heat pump regulator to be controlled remotely.

If such a connection is desired, install a screened network cable (category 6, with RJ-45 plug) through the unit when installing the connections and run it through the front facade of the unit, parallel to the already-present heating and heat pump regulator control cable.

5. Close electrical switch box of unit.
6. Attach the lower facing panels.

24 Rinsing, filling and bleeding the system

! IMPORTANT

The system must be absolutely free from air before commissioning.

Unsuitable quality of the water for filling up and replenishing the heating circuit

The efficiency of the system and the service life of the heat generator and the heating components depend decisively on the quality of the heating water.

If the system is filled with untreated drinking water, calcium deposits will form as scale. Lime scale deposits accumulate on the heat transfer surfaces of the heating. The efficiency is reduced and energy costs increase. In extreme cases, the heat exchangers will be damaged.

Heating water quality



NOTE

- For detailed information refer, among other things, to the VDI Guidelines 2035 “Vermeidung von Schäden in Warmwasserheizanlagen” (preventing damage in hot water heating systems)
 - Required pH value: 8.2 ... 10;
for aluminium materials:
pH value: 8.2 ... 8.5
- ▶ Fill the system with deionised heating water (VE water) or with water corresponding to the VDI 2035 norm only (low-salt operation of the system).

Advantages of low-salt operation:

- Low corrosion-promoting properties
 - No formation of mineral scale
 - Ideal for closed heating circuits
 - Ideal pH value due to self-alkalisation after filling the system
- ▶ If the required water quality is not achieved, consult a company specialising in the treatment of heating water.
- ▶ Keep a system log for hot water heating systems in which relevant planning data is entered (VDI 2035).



Monitoring

Analytical recording and monitoring of the relevant water values and the added active conditioning substances is of decisive importance. Therefore, they should be monitored regularly using appropriate water test equipment.

Rinsing, filling and bleeding

To bleed the hot water tank, the heating circuit and hot water circuit must be rinsed simultaneously.

1. Rinse, Fill and bleed the heating circuit.
2. In addition, bleed the condensor of the heat pump.
 - 2.1. Open the lower facing panel.
 - 2.2. Open the bleeding valve (①).

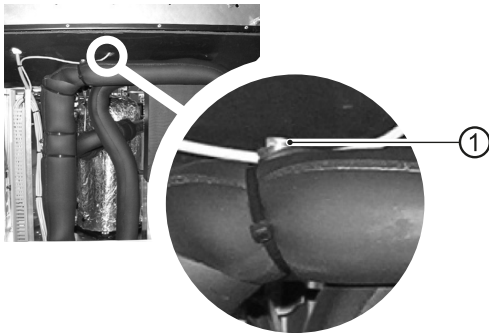

3. Following bleeding, close the lower facing panel.

25 Insulating the hydraulic connections

Insulate the vibration decouplers and the pipes of the heating circuit.



NOTE

Insulate in accordance with applicable local standards and directives.

26 Installation of the control element

Situated at different heights in the front facade of the unit are recesses (each with 4 recesses) for the fastening of the control element:

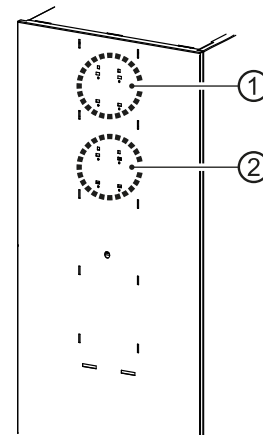

- 1 four upper recesses
- 2 four lower recesses

4 hooks are located on the back side of the control element and can be used to hang the control element on the front facade of the unit:

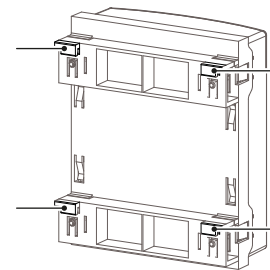

1. Hang the control element's hooks on the recesses of the front facade (either in the upper or lower recesses).

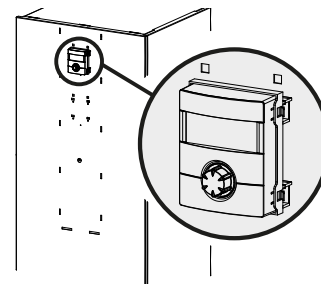

Example:
Control element in upper recesses



2. Push the control element down until it locks into position.

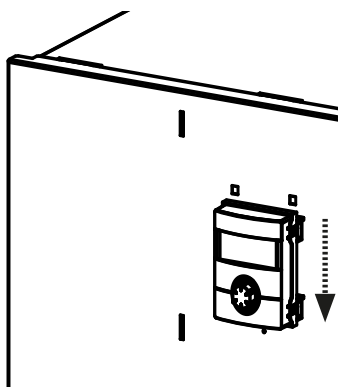

3. Stick the heating and heat pump regulator's control cable into the **right** bushing on the bottom of the control element.

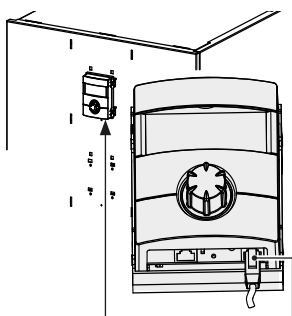

NOTE

A connection to a computer or a network can be installed via the left bushing on the bottom of the control element, thus allowing the heating and heat pump regulator to be controlled remotely. One pre-condition is that a screened network cable (category 6) be installed through the unit when installing the unit.

- Operating manual for the heating and heat pump regulator, part 2, "Web server" section.

If this network cable is available, insert the network cable's RJ-45 plug into the left bushing of the control element.



NOTE

The network cable can be exchanged at any time. In order to be able to connect it, the screen must first be removed.

27 Installation and removal of the screen

27.1 Installing the screen



NOTE

The screen is provided at the time of delivery so that the control element may be inserted in the upper recesses of the front facade. If the control element has been inserted in the lower recesses of the front facade, you must first remove the screen's temporary cover and then reinsert it above the logo.

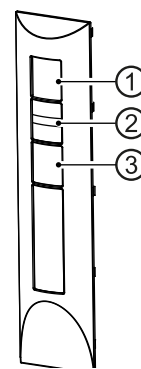

Screen at time of delivery:

- 1 recess for control element
- 2 logo
- 3 temporary cover

1. First, insert the screen **below**, in the provided slots on the front of the facade.

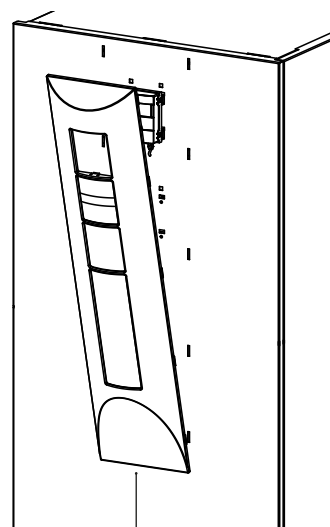



2. Beginning first on one side and moving upwards, lock the screen's snap-in lugs in place **in the slots** provided on the front of the facade.

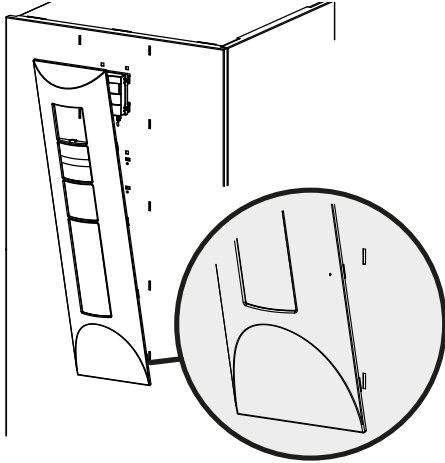

3. **Next, on the opposite side, moving upwards.** lock the screen's snap-in lugs **in place** in the slots provided on the front of the facade.
4. Finally, press the screen's upper snap-in lugs into the slots provided on the front of the facade.

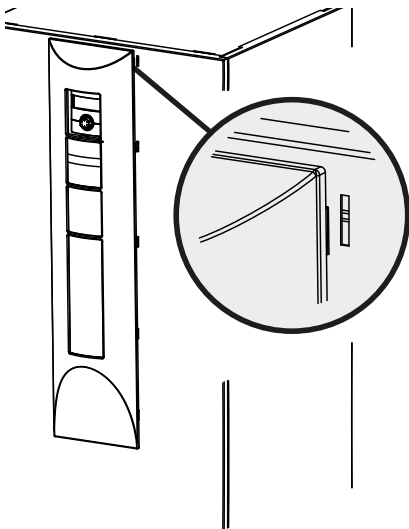

27.2 Removing the screen

In order to remove the screen, the snap-in lugs must **first be loosened by pressing one side completely toward the middle of the screen.**

Thereafter, remove the snap-in lugs from the opposite side.

28 Set the overflow valve



REMARQUE

The activities in this section are only necessary for in-line tank integration.

Complete the worksteps quickly, otherwise the maximum return temperature can be exceeded and the heat pump switches to high-pressure fault.

Turn the adjusting knob at the overflow valve to the right to increase the temperature difference (the temperature drop), turn it to the left to reduce it.

System is running in heating mode (ideally in cold condition).

1. In case of low heating curve: Set the system to "Forced heating".
→ Operating manual of the heating and heat pump controller
2. Shut off valves to the heating circuit.
3. Ensure that the total flow is routed via the overflow valve.
4. Read out the flow and return temperature at the heating and heat pump controller.
→ Operating manual of the heating and heat pump controller
5. Turn the adjusting knob (①) of the overflow valve (②) until the temperature drop between the flow and return temperature is set as follows:

External temperature	Recommended settings
-10 °C	4 K
0 °C	5 K
10 °C	8 K
20 °C	9 K
30 °C	10 K

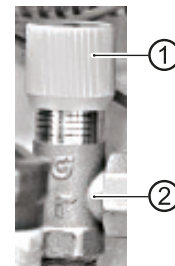

6. Open valves to heating circuit.
7. Reset the heating and heat pump controller.



29 Commissioning



DANGER

The unit may only be started up if the air ducts, weather and/or rain louvres have been installed and the facing panels are closed.



NOTE

The commissioning has to be in the heating mode.

1. Carry out a thorough installation check and work through the general checklist.

→ Manufacturer's homepage

By checking the installation you prevent damage to the heat pump system, which could be caused by work carried out improperly.

Check that.

- **clockwise rotary field** of the load power supply (compressor) is ensured.
 - The heat pump **installation and assembly** have been carried out according to the requirements of this operating manual.
 - the electrical installation work has been completed properly.
 - The power supply for the heat pump must be equipped with an all-pole automatic circuit-breaker with at least 3 mm contact spacing to IEC 60947-2.
 - The heating circuit is flushed, filled and thoroughly vented.
 - All valves and shut-off devices of the heating circuit are open.
 - All pipe systems and components of the system are leaktight.
2. Carefully fill out and sign the completion report for heat pump systems...

→ Manufacturer's homepage

3. Within Germany:
Send completion report for heat pump systems and general checklist to the manufacturer's factory customer service department.

In other countries:

Send completion report for heat pump systems and general checklist to the manufacturer's local partner.

4. The heat pump system is commissioned by customer service personnel authorised by the manufacturer. There is a fee for starting up!

30 Maintenance of the unit

The cooling circuit of the heat pump requires no regular maintenance.

According to EU regulation (EC) 517/2014, leak inspections and maintenance of a log book are required by law for certain heat pumps!

→ Logbook for heat pumps, Section "Information on use of the log book"

The components of the heating circuit and the heat source (valves, expansion vessels, circulating pumps, filters, dirt traps) should be inspected as well as cleaned as needed - at the very least annually - by a qualified heating or cooling system technician.

! IMPORTANT

Regularly check to ensure that the condensate can drain out of the unit unobstructed. To do this, regularly check the condensate tray in the unit and the condensate drain for dirt / blockages and if necessary clean.

Always regularly control for unimpeded air infeed accordingly. Constrictions or even blockages which, for example occur

- when applying house insulation with polystyrene balls
- through packaging material (foils, films, cartons etc.)
- through foliage, snow, icing or similar weather-related deposits
- through vegetation (bushes, tall grass etc.)
- through air shaft covers (fly protection screens etc.)

and which must be prevented and/or removed immediately.

Icing of the protective grating

If temperatures fall below freezing and humidity is high at the same time, ice can form on the protective grating. In order to ensure problem-free operation, the ice must be removed at regular intervals.



30.1 Annual maintenance

- Determine the quality of the heating water by analysis. In the event of deviations from the specifications, take suitable measures without delay.

It is best to arrange a maintenance agreement with a heating installation company. The company will conduct the required maintenance at regular intervals.



NOTE

Any person who works on the refrigerant circuit must have a qualification certificate issued by a body accredited by the industry.

30.2 Cleaning and rinsing of unit components



WARNING

Unit components may be cleaned and rinsed only by customer service personnel authorized by the manufacturer. Use only liquids recommended by the manufacturer. Rinsing of the liquefier with chemical cleaning agents must be followed by neutralization of residue and intensive rinsing with water. Always observe the technical data of the manufacturer of the heat exchanger.

31 Malfunctions

In the event of a malfunction, you can detect the cause of the malfunction via the diagnostic program of the heating and heat pump regulator.

- Operating manual of the heating and heat pump regulator



WARNING

Service and repair work on the components of the unit may be performed only by customer service personnel authorized by the manufacturer.



NOTE

If the safety temperature limiter on the electric heating element (depending on unit model) has tripped, no fault is displayed.

31.1 Unlock the safety temperature limiter

A safety temperature limiter is installed in the electric heating element (depending on unit model). If the heat pump fails or there is air in the system:

- Check whether the reset button (②) of the safety temperature limiter (①) has jumped out (by approx. 2 mm).

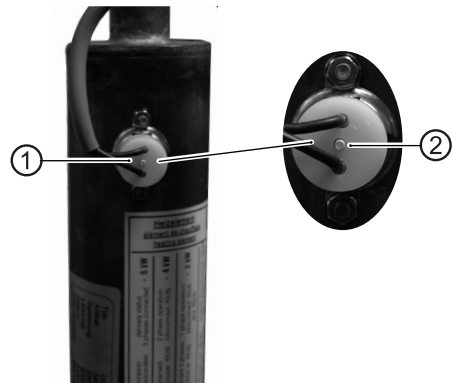

- Press the reset button (②) back in again.
- If the safety temperature limiter trips again, contact the local partner of the manufacturer or the factory's customer service.



32 Dismantling



DANGER

Danger of fatal injury due to electric current!

Electrical connections may be installed only by qualified electricians.

Before opening the unit, disconnect the system from the power supply and secure it from being switched back on!



WARNING

Only qualified heating or cooling system technicians are allowed to remove the unit from the system.



IMPORTANT

Recycle or provide for proper disposal of unit components, refrigerants and oil in accordance with the applicable regulations, standards and directives.

32.1 Removal of the buffer battery



IMPORTANT

Before scrapping the heating and heat pump regulator, remove the buffer battery on the processor board. The battery can be pushed out using a screwdriver. Dispose of battery and electronic components in keeping with environmental considerations.



Technical data / scope of delivery

Heat pump type	Brine/water Air/water Water/water	• applicable — not applicable
Installation location	Indoors Outdoors	• applicable — not applicable
Conformity		CE
Performance data	Heating capacity/COP at	
	A7/W35 Standard point acc. to DIN EN 14511-x: 2013	2 Compressors 1 Compressor kW ... kW ...
	A7/W45 Standard point acc. to DIN EN 14511-x: 2013	2 Compressors 1 Compressor kW ... kW ...
	A2/W35 Operating point according to DIN EN 14511-x: 2013	2 Compressors 1 Compressor kW ... kW ...
	A10/W35 Operating point according to DIN EN 14511-x: 2013	2 Compressors 1 Compressor kW ... kW ...
	A-7/W35 Operating point according to DIN EN 14511-x: 2013	2 Compressors 1 Compressor kW ... kW ...
	A-15/W65	2 Compressors 1 Compressor kW ... kW ...
Limits of application	Heating circuit	°C
	Heat source	°C
	Additional operating points	°C
Sound	Internal sound pressure level (open air test field, distance of 1m around the engine, average)	dB(A)
	External sound pressure level (open air test field, distance of 1m around the air supplies, average) (2x 1m original straight air duct)	dB(A)
	Sound power level, inside	dB(A)
	Sound power level, outside	dB(A)
Heat source	Air volume flow at maximum external compression	m³/h
	Maximum external pressure	Pa
Heating circuit	Volume flow: minimum flow rate nominal flow rate A7/W35 DIN EN 14511-x: 2013 maximum flow rate	l/h
	Pressure loss heat pump Δp volume flow	bar l/h
	Free compression heat pump Δp volume flow	bar l/h
	Content of buffer tank	l
	3-way valve, heating/hot water	...
General unit data	Dimensions (see dimensional drawing for the specified unit size)	unit size
	Total weight	kg
	Connections Heating circuit	...
	Heat source	...
	Refrigerant Refrigerant type Quantity	... kg
	Free cross section, air channels	mm
	Cross section, condensate water / length from unit	mm m
Electric	Voltage code all-pole circuit breaker heat pump **)	... A
	Voltage code circuit breaker control voltage **)	... A
	Voltage code circuit breaker electric heating element **)	A
Heat Pump	Effective power consumption in standard point A7/W35 acc. to DIN EN 14511-x: 2013: Power consumption current consumption $\cos\phi$	kW A ...
	Maximum device current within the limits of application	A
	Starting current: direct with soft starter	A A
	Protection type	IP
	Output electric heating element 3 2 1 phase	kW kW kW
Components	Circulating pump heating circuit at nominal flow rate: Power consumption current consumption	kW A
Safety equipment	Safety component heating circuit Safety component heat source	Includ. in sc. of del.: • yes — no
Heating and heat pump regulator		Includ. in scope of delivery: • yes — no
Control and sensor wire		Includ. in scope of delivery: • yes — no
Power cable to unit		Includ. in scope of delivery: • yes — no
Electronic soft starter		integrated: • yes — no
Expansion vessels	Heat source: Scope of delivery Volume Initial pressure	• yes — no bar
Overflow valve		integrated: • yes — no
Vibration decouplers	Heating circuit heat source	Included in scope of delivery: • yes — no

UK813517b

*) depending on components tolerances and flow **) comply with local regulations n.n. = not detectable w.w. = to choice
 1) hot water return 2) hot water flow The performance data and the operating limits apply to clean heat exchangers



	LW 140(L)	LW 180(L)	LW 251(L)
	— • —	— • —	— • —
	• —	• —	• —
	•	•	•
	—	19.6 3.9	27.3 3.9
	14.4 4.3	10.1 4.2	14.1 4.2
	—	18.7 3.3	26.1 3.3
	13.9 3.5	9.8 3.4	13.7 3.4
	—	17.2 3.6	24.0 3.6
	13.8 3.7	9.5 3.8	13.2 3.8
	—	21.2 4.0	29.2 4.0
	14.1 4.4	10.3 4.5	14.2 4.5
	—	14.1 2.8	19.4 2.8
	10.8 3.0	7.3 2.9	10.1 2.9
	—	—	—
	—	—	—
	20 ¹ – 50 ²	20 ¹ – 50 ²	20 ¹ – 50 ²
	-20 – 35	-20 – 35	-20 – 35
	A> -7 / 60 ²	A> -7 / 60 ²	A> -7 / 60 ²
	50	51	55
	51	52	53
	—	—	—
	56	57	58
	5600	5600	7800
	25	25	25
	2000 2900 3600	2000 3800 4800	2500 5000 6200
	0.12 2900	0.18 3800	0.12 5000
	— —	— —	— —
	—	—	—
	—	—	—
	4	4	5
	370	420	540
	G5/4*AG	G5/4*AG	G5/4*AG
	—	—	—
	R407C 5.8	R407C 6.8	R407C 9.8
	770 x 770	770 x 770	770 x 770
	30 1	30 1	30 1
	3~N/PE/400V/50Hz C16	3~N/PE/400V/50Hz C20	3~N/PE/400V/50Hz C25
	1~N/PE/230V/50Hz B10	1~N/PE/230V/50Hz B10	1~N/PE/230V/50Hz B10
	3~N/PE/400V/50Hz B16	3~N/PE/400V/50Hz B16	3~N/PE/400V/50Hz B16
	3.4 7.0 0.7	5.0 (2.4) 10.3 (4.9) 0.7 (0.7)	7.0 (3.4) 14.4 (7.0) 0.7 (0.7)
	13.0	18.0	24.5
	74 26	51.5 30	74 30
	20	20	20
	9 6 3	9 6 3	9 6 3
	— —	— —	— —
	— —	— —	— —
	•	•	•
	—	—	—
	—	—	—
	•	•	•
	— — —	— — —	— — —
	—	—	—
	—	—	—
	813522d	813523e	813524e



LW 140(L)

Performance curves

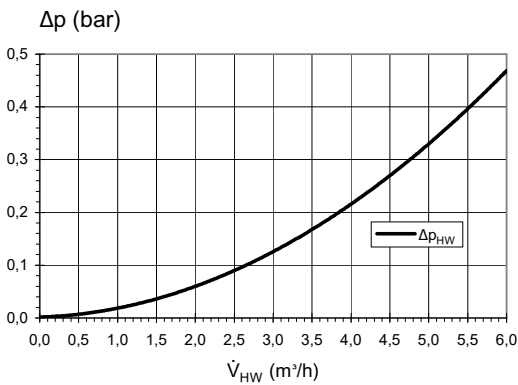
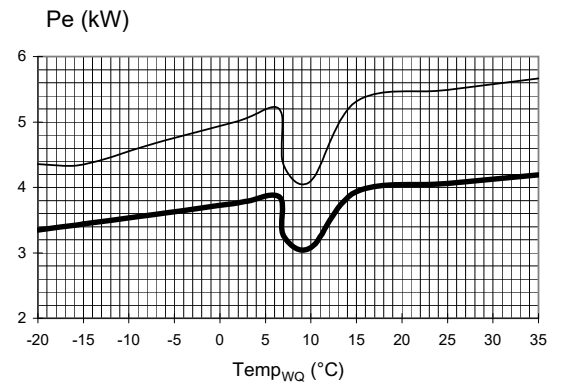
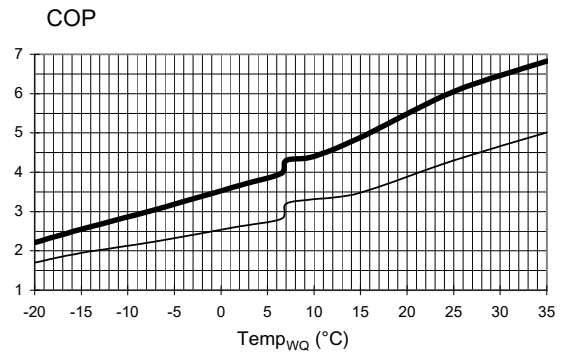
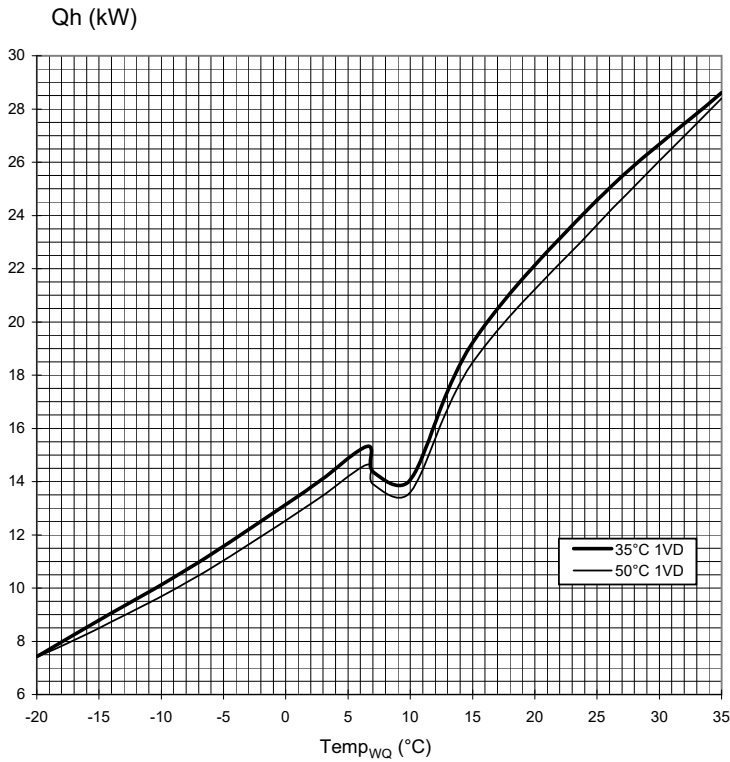

823154

Legend:	UK823129L/170408
\dot{V}_{HW}	Volume flow, heating water
$Temp_{WQ}$	Temperature, heat source
Q_h	Heating capacity
P_e	Power consumption
COP	Coefficient of performance / efficiency rating
Δp_{HW}	Pressure loss heat pump
VD	Compressor(s)



Performance curves

LW 180(L)

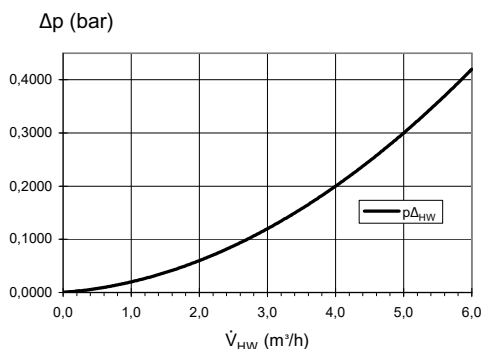
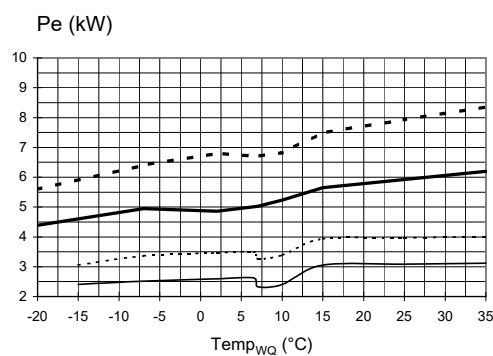
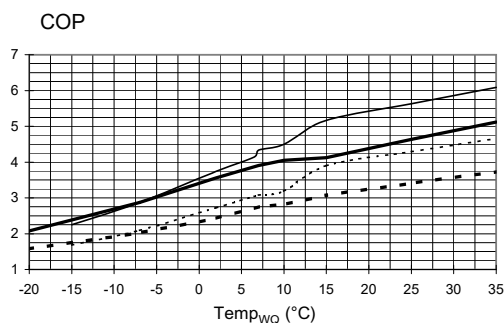
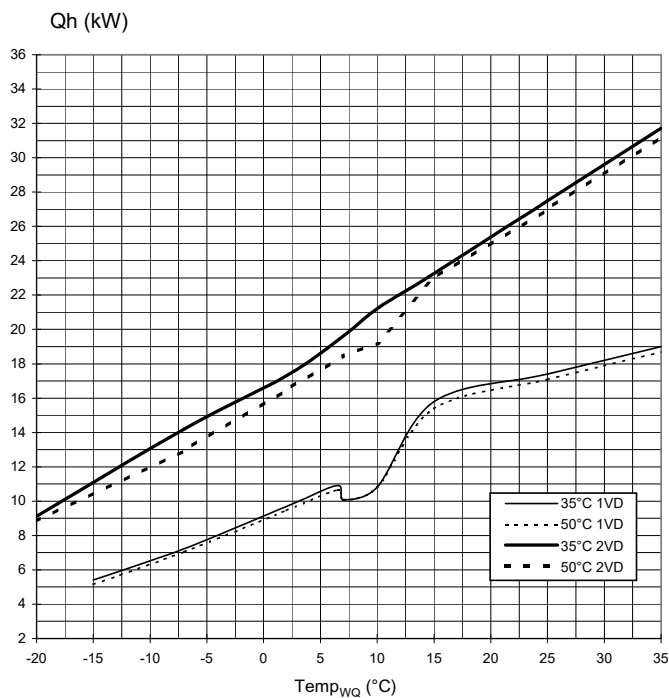

823155

Legend:	UK823129L/170408
V _{HW}	Volume flow, heating water
Temp _{WQ}	Temperature, heat source
Qh	Heating capacity
Pe	Power consumption
COP	Coefficient of performance / efficiency rating
Δp _{HW}	Pressure loss heat pump
VD	Compressor(s)



LW 251(L)

Performance curves

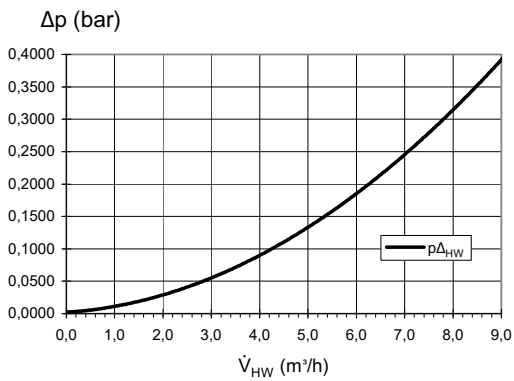
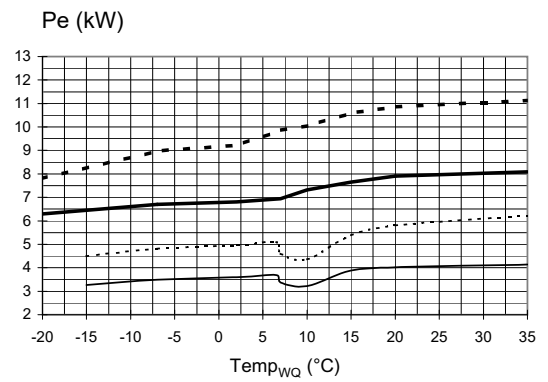
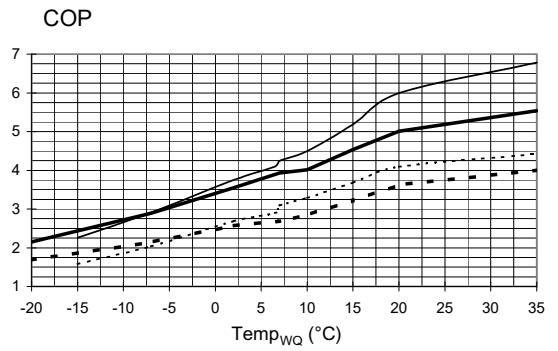
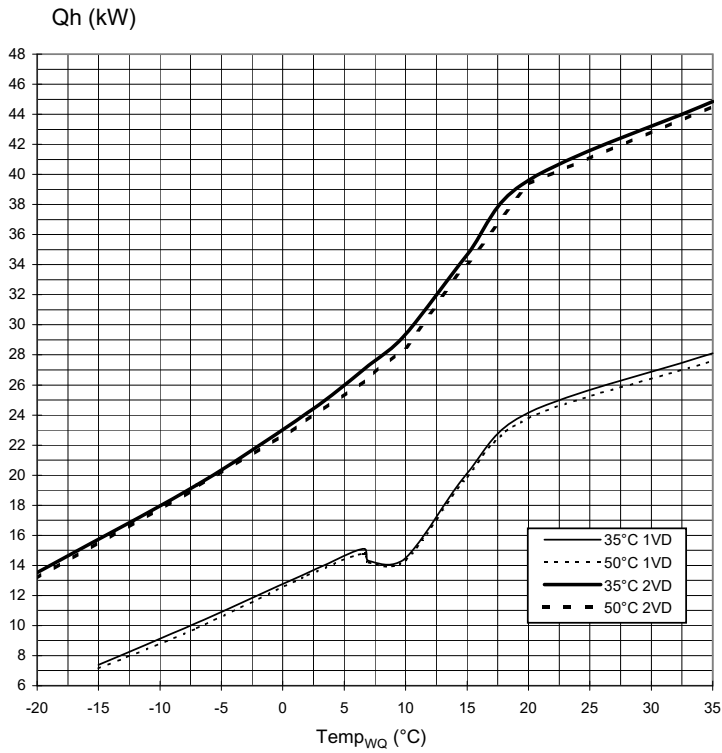

823156a

Legend:	UK823129L/170408
V _{HW}	Volume flow, heating water
Temp _{WQ}	Temperature, heat source
Qh	Heating capacity
Pe	Power consumption
COP	Coefficient of performance / efficiency rating
Δp _{HW}	Pressure loss heat pump
VD	Compressor(s)



LW 140 – LW 180

Dimensional drawings

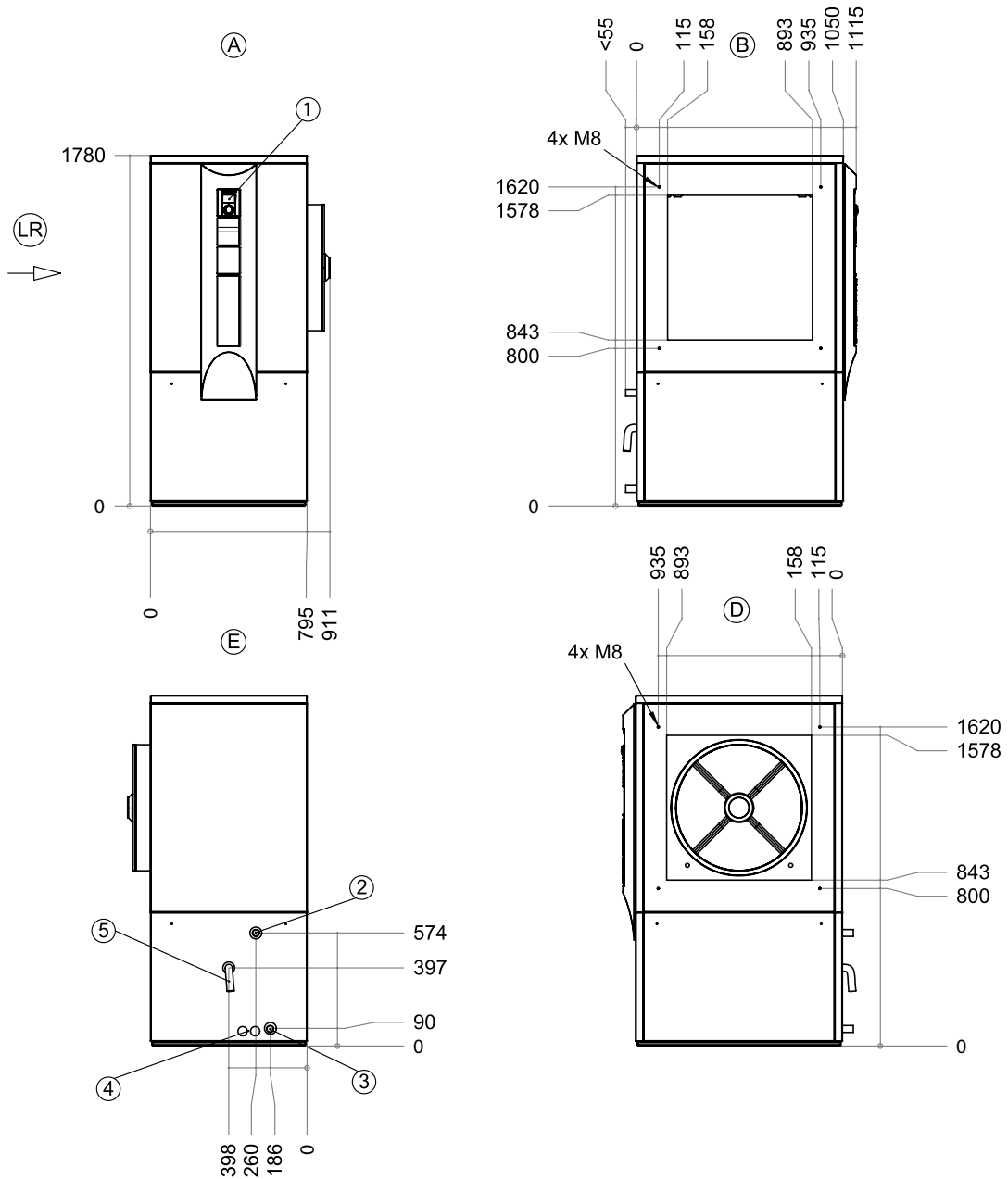

Legend: UK819355b
All dimensions in mm.

- A Front view
- B Side view from left
- D Side view from right
- E Rear view
- LR Air direction

- | Item | Designation |
|------|---|
| 1 | Control panel |
| 2 | Hot water outlet (flow) |
| 3 | Hot water inlet (return) |
| 4 | Bushings for electrical / sensor cables |
| 5 | Condensate hose \varnothing i 30 |

G 5/4" DIN ISO 228
G 5/4" DIN ISO 228

Length from device 1m



Dimensional drawings

LW 140L – LW 180L

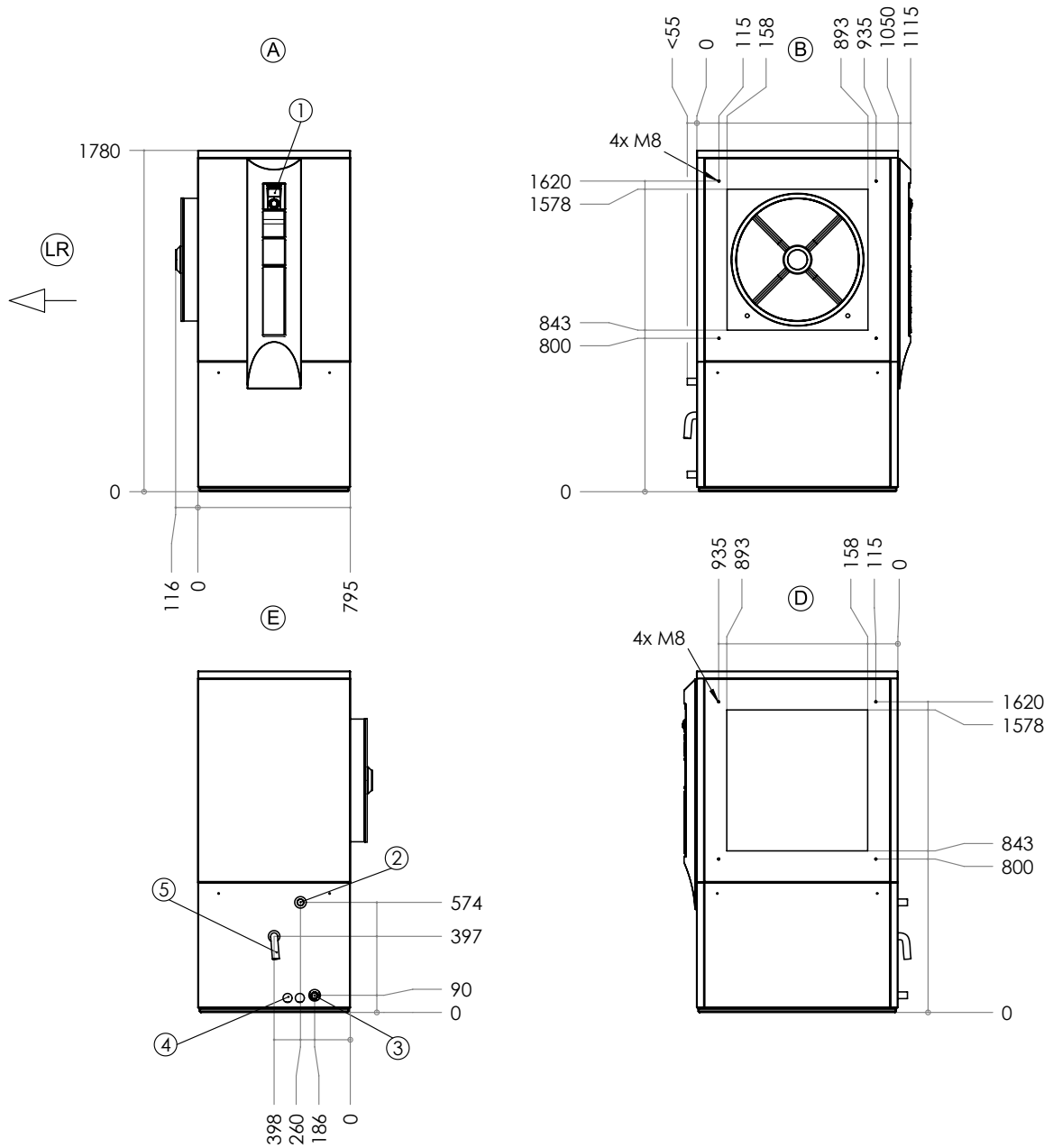

Legend: UK819356a
All dimensions in mm.

- A Front view
- B Side view from left
- D Side view from right
- E Rear view
- LR Air direction

Item	Designation
1	Control panel
2	Hot water outlet (flow)
3	Hot water inlet (return)
4	Bushings for electrical / sensor cables
5	Condensate hose \varnothing i 30

G 5/4" DIN ISO 228

G 5/4" DIN ISO 228

Length from device 1m



LW 251

Dimensional drawings

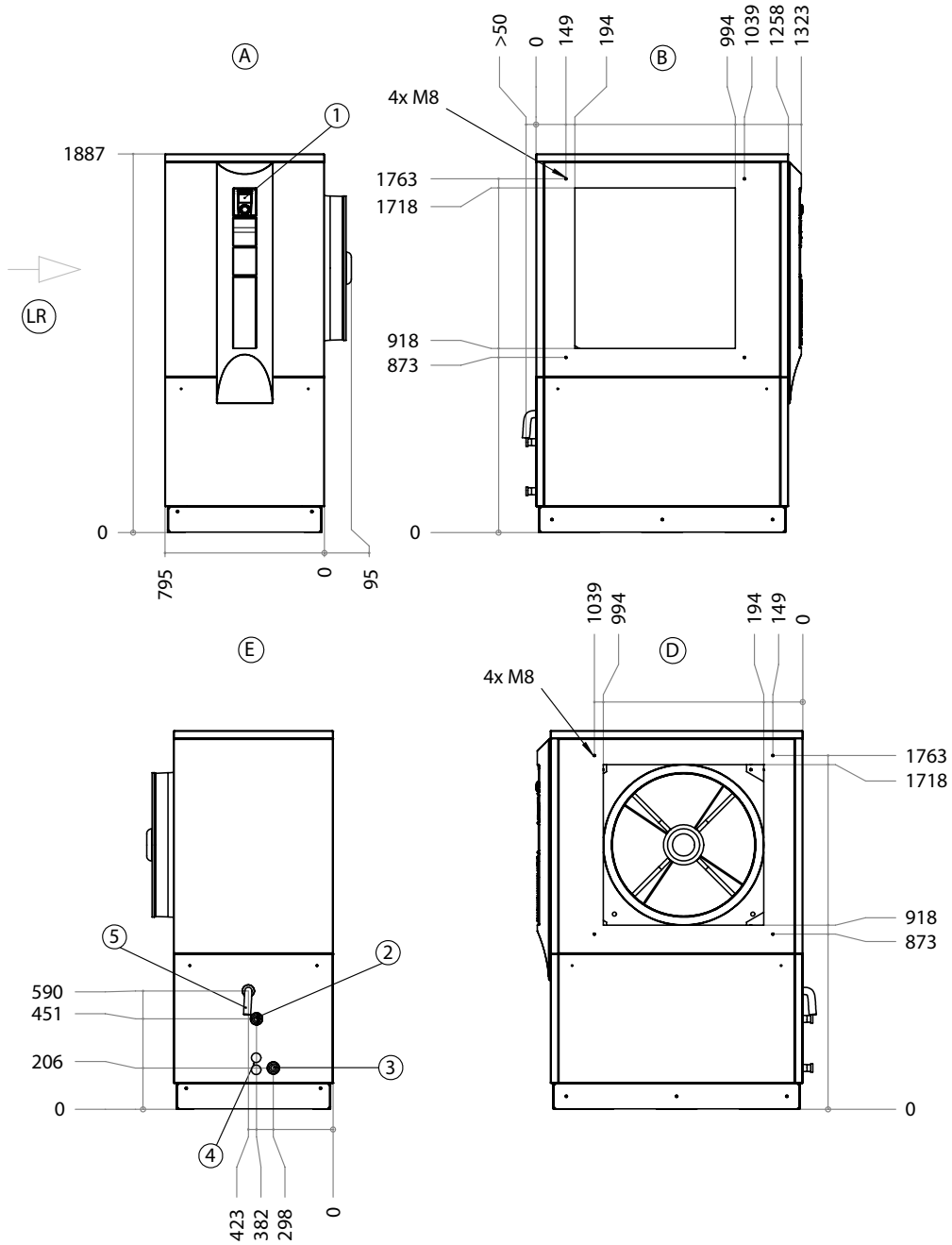

Legend: UK819357b
All dimensions in mm.

- A Front view
- B Side view from left
- D Side view from right
- E Rear view
- LR Air direction

- | Item | Designation |
|------|---|
| 1 | Control panel |
| 2 | Hot water outlet (flow) |
| 3 | Hot water inlet (return) |
| 4 | Bushings for electrical / sensor cables |
| 5 | Condensate hose \varnothing i 30 |

G 5/4" DIN ISO 228
G 5/4" DIN ISO 228

Length from device 1m



Dimensional drawings

LW 251L

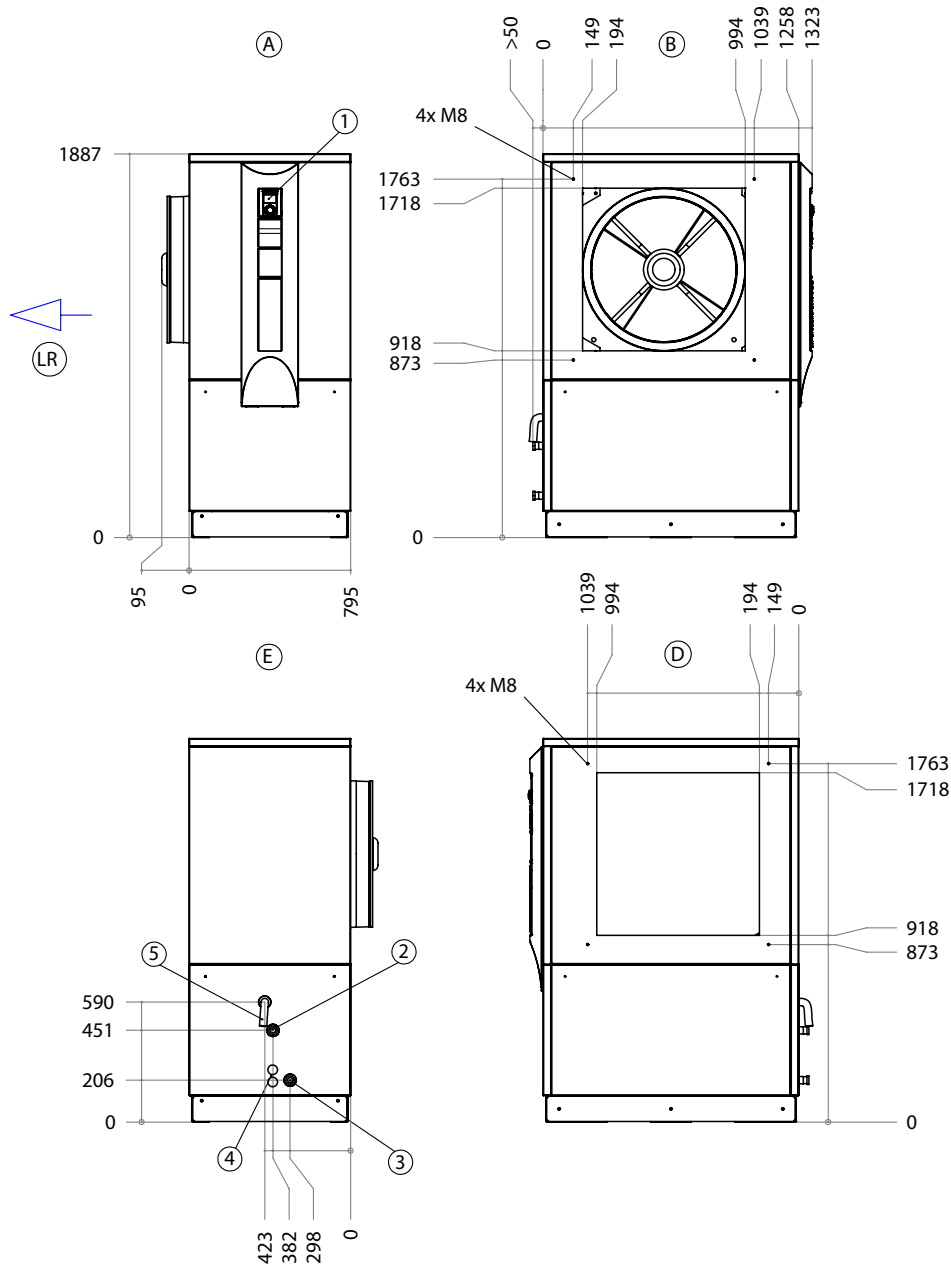

Legend: UK819358b
All dimensions in mm.

- A Front view
- B Side view from left
- D Side view from right
- E Rear view
- LR Air direction

Item	Designation
1	Control panel
2	Hot water outlet (flow)
3	Hot water inlet (return)
4	Bushings for electrical / sensor cables
5	Condensate hose \varnothing i 30

G 5/4" DIN ISO 228
G 5/4" DIN ISO 228

Length from device 1m



LW 140(L) – LW 180(L)

Installation plan version 1

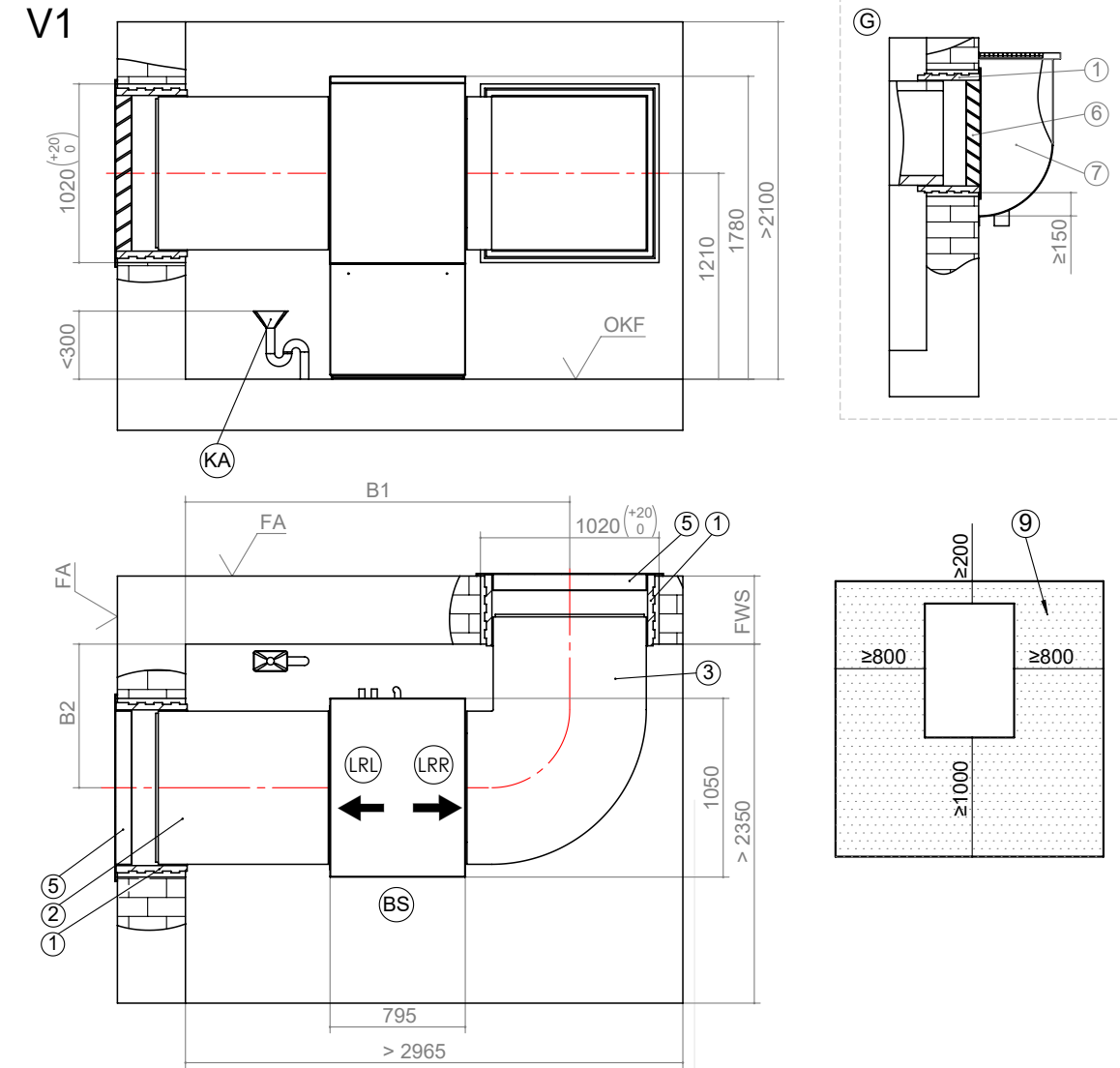

Item	Designation	Dim.
B1	With finished wall thickness 240 to 320	2340
	With finished wall thickness 320 to 400	2260
B2	With finished wall thickness 240 to 320	920
	With finished wall thickness 320 to 400	840

V1	Version 1
OKF	Top edge of finished floor
FA	Finished outer façade
LR	Air direction
LRR	Air direction on machines with fan right
LRL	Air direction on machines with fan left
BS	Operator side
FWS	Finished wall thickness
KA	Condensate discharge
G	Section installation in light well

Legende: UK819336c-1

All dimensions in mm.

Item	Designation
1	Accessory: wall duct 1000x1000x420
2	Accessory air duct 900x900x1000
3	Accessory: air duct bend 900x1050x1450
5	Installation above ground level Accessory: weather guard 1045x1050
6	Installation in light well Accessory: rain guard 1045x1050
7	provided by customer: light well with water drain min. exposed cross section 0,75m ²
9	Minimum clearance for service purposes If the distances were to be reduced to the minimum dimension, the air ducts must be made shorter. This leads to a significant increase in the sound intensity level!

Tilting dimension of heat pumps = 1950mm



Installation plan version 2

LW 140(L) – LW 180(L)

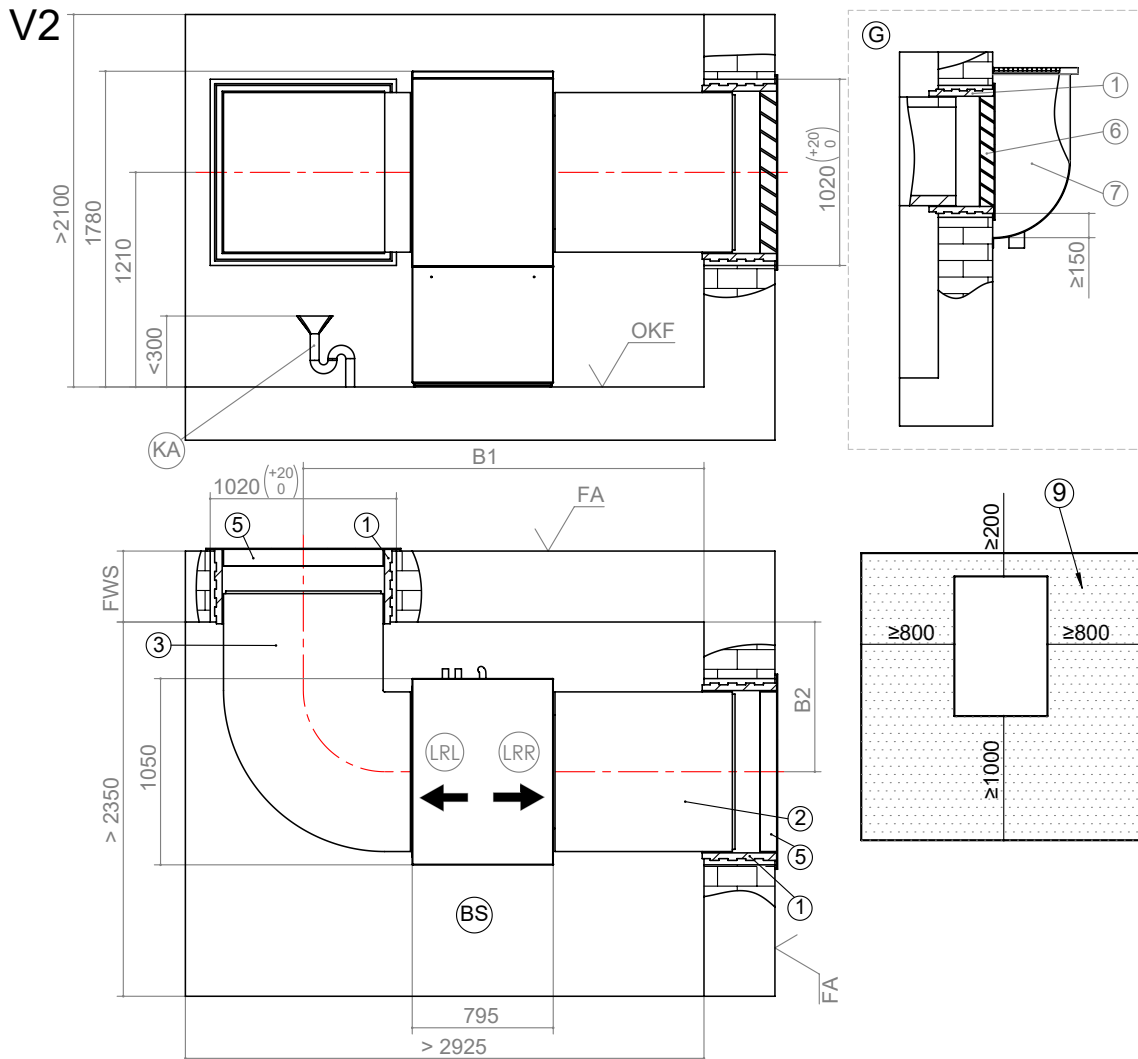

Item	Designation	Dim.
B1	With finished wall thickness 240 to 320	2340
	With finished wall thickness 320 to 400	2260
B2	With finished wall thickness 240 to 320	920
	With finished wall thickness 320 to 400	840

V2	Version 2
OKF	Top edge of finished floor
FA	Finished outer façade
LR	Air direction
LRR	Air direction on machines with fan right
LRL	Air direction on machines with fan left
BS	Operator side
FWS	Finished wall thickness
KA	Condensate discharge
G	Section installation in light well

Tilting dimension of heat pumps = 1950mm

Legende: UK819336c-2
All dimensions in mm.

Item	Designation
1	Accessory: wall duct 1000x1000x420
2	Accessory air duct 900x900x1000
3	Accessory: air duct bend 900x1050x1450
5	Installation above ground level Accessory: weather guard 1045x1050
6	Installation in light well Accessory: rain guard 1045x1050
7	provided by customer: light well with water drain min. exposed cross section 0,75m ²
9	Minimum clearance for service purposes If the distances were to be reduced to the minimum dimension, the air ducts must be made shorter. This leads to a significant increase in the sound intensity level!



LW 140(L) – LW 180(L)

Installation plan version 3

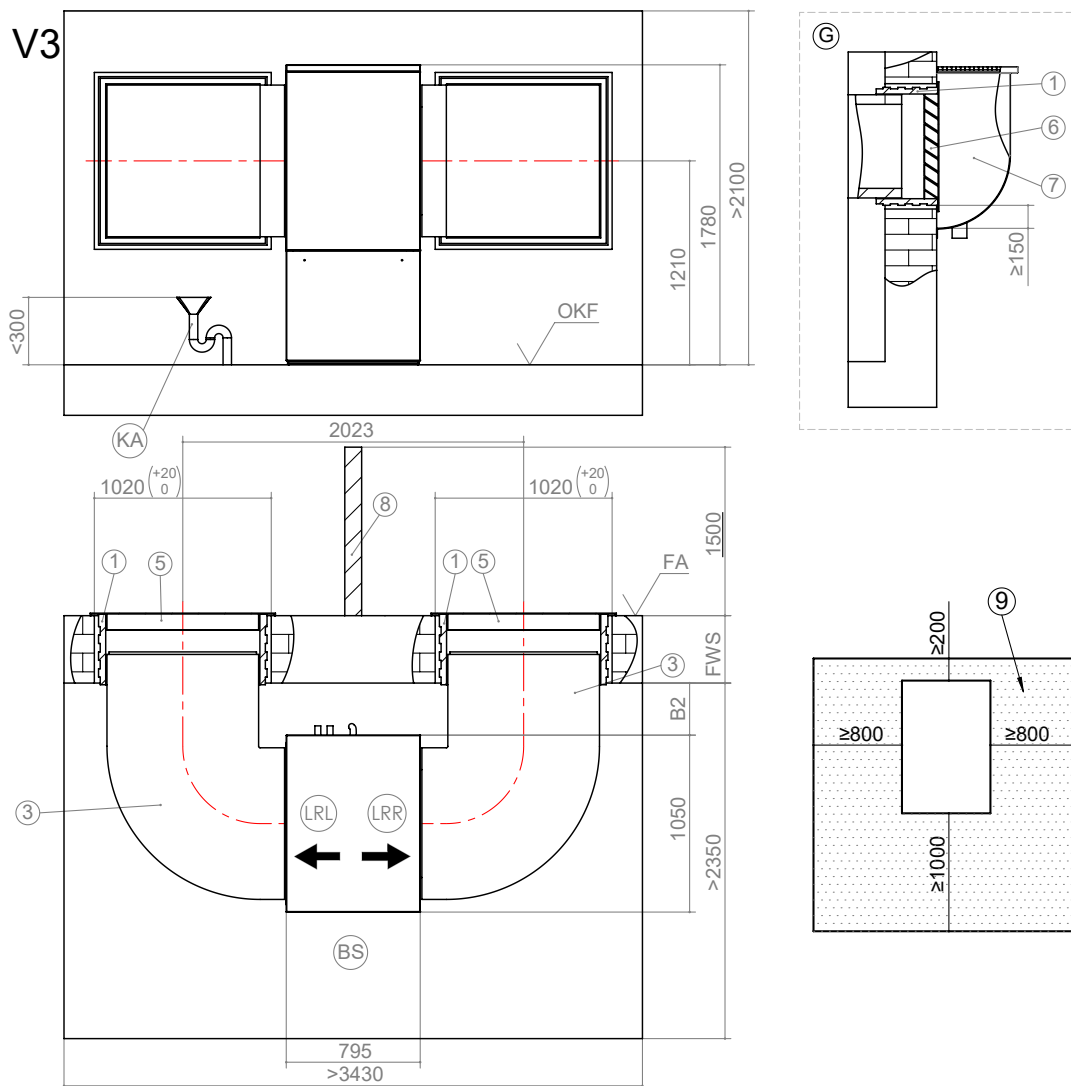

Item	Designation	Dim.
B2	With finished wall thickness 240 to 320	390
	With finished wall thickness 320 to 400	310

V3	Version 3
OKF	Top edge of finished floor
FA	Finished outer façade
LR	Air direction
LRR	Air direction on machines with fan right
LRL	Air direction on machines with fan left
BS	Operator side
FWS	Finished wall thickness
KA	Condensate discharge
G	Section installation in light well

Tilting dimension of heat pumps = 1950mm

Legende: UK819336c-3

All dimensions in mm.

Item	Designation
1	Accessory: wall duct 1000x1000x420
3	Accessory air duct bend 900x1050x1450
5	Installation above ground level Accessory: weather guard 1045x1050
6	installation in light well Accessory: rain guard 1045x1050
7	provided by customer: light well with water drain min. exposed cross section 0,75m ²
8	Ventilation separation: Depth 1000 Height by light well installation 1000 Height by installation above ground level 1700, 300 above weather guard
9	Minimum clearance for service purposes If the distances were to be reduced to the minimum dimension, the air ducts must be made shorter. This leads to a significant increase in the sound intensity level!



Installation plan version 4

LW 140(L) – LW 180(L)

V4

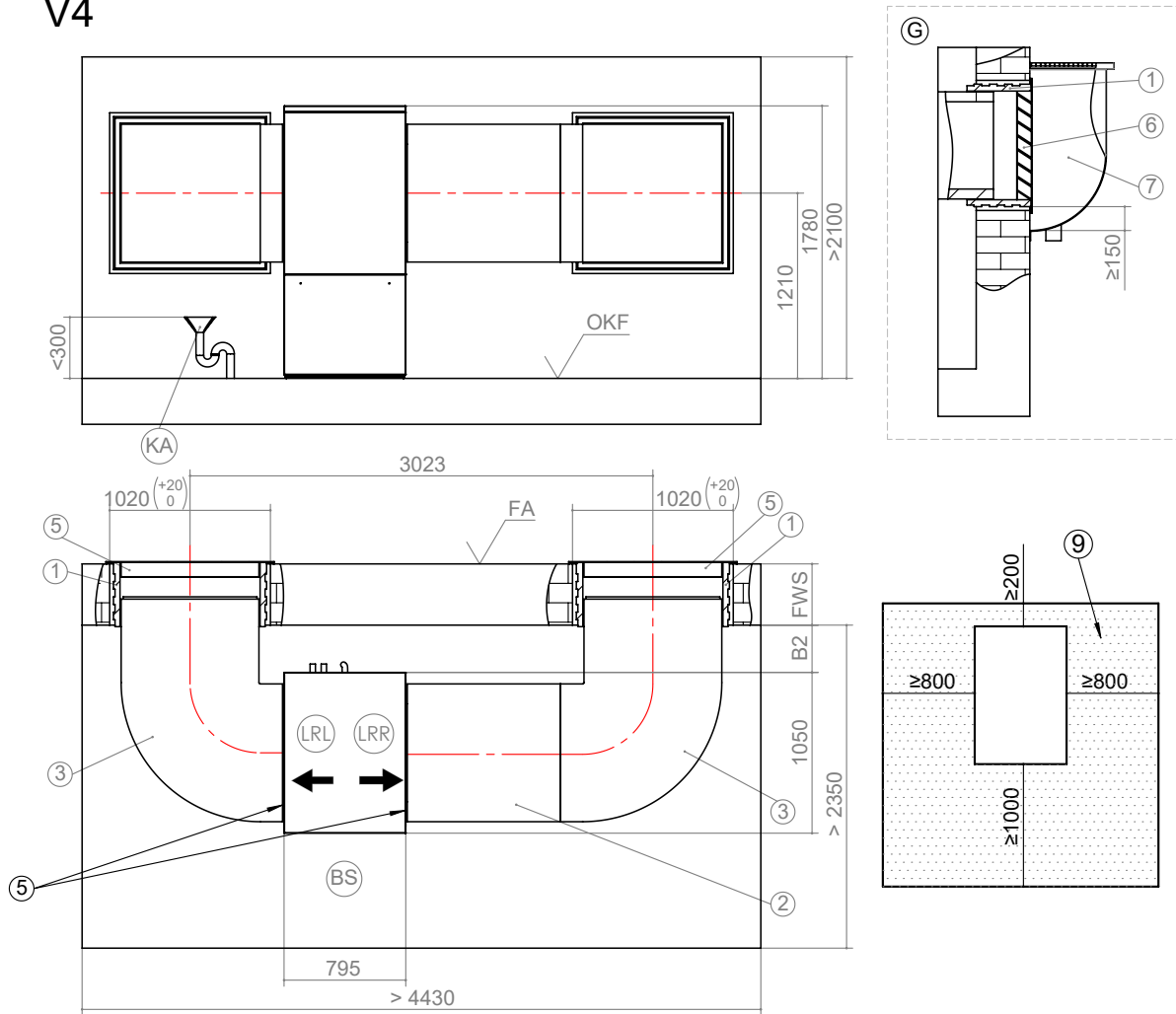

Item	Designation	Dim.	Legende: UK819336c-4
B2	With finished wall thickness 240 to 320 With finished wall thickness 320 to 400	390 310	All dimensions in mm.

V4	Version 4
OKF	Top edge of finished floor
FA	Finished outer façade
LR	Air direction
LRR	Air direction on machines with fan right
LRL	Air direction on machines with fan left
BS	Operator side
FWS	Finished wall thickness
KA	Condensate discharge
G	Section installation in light well

Tilting dimension of heat pumps = 1950mm

Item	Designation
1	Accessory: wall duct 1000x1000x420
2	Accessory air duct 900x900x1000
3	Accessory: air duct bend 900x1050x1450
5	Installation above ground level Accessory: weather guard 1045x1050
6	installation in light well Accessory: rain guard 1045x1050
7	provided by customer: light well with water drain min. exposed cross section 0,75m ²
9	Minimum clearance for service purposes If the distances were to be reduced to the minimum dimension, the air ducts must be made shorter. This leads to a significant increase in the sound intensity level!



LW 251(L)

Installation plan version 1

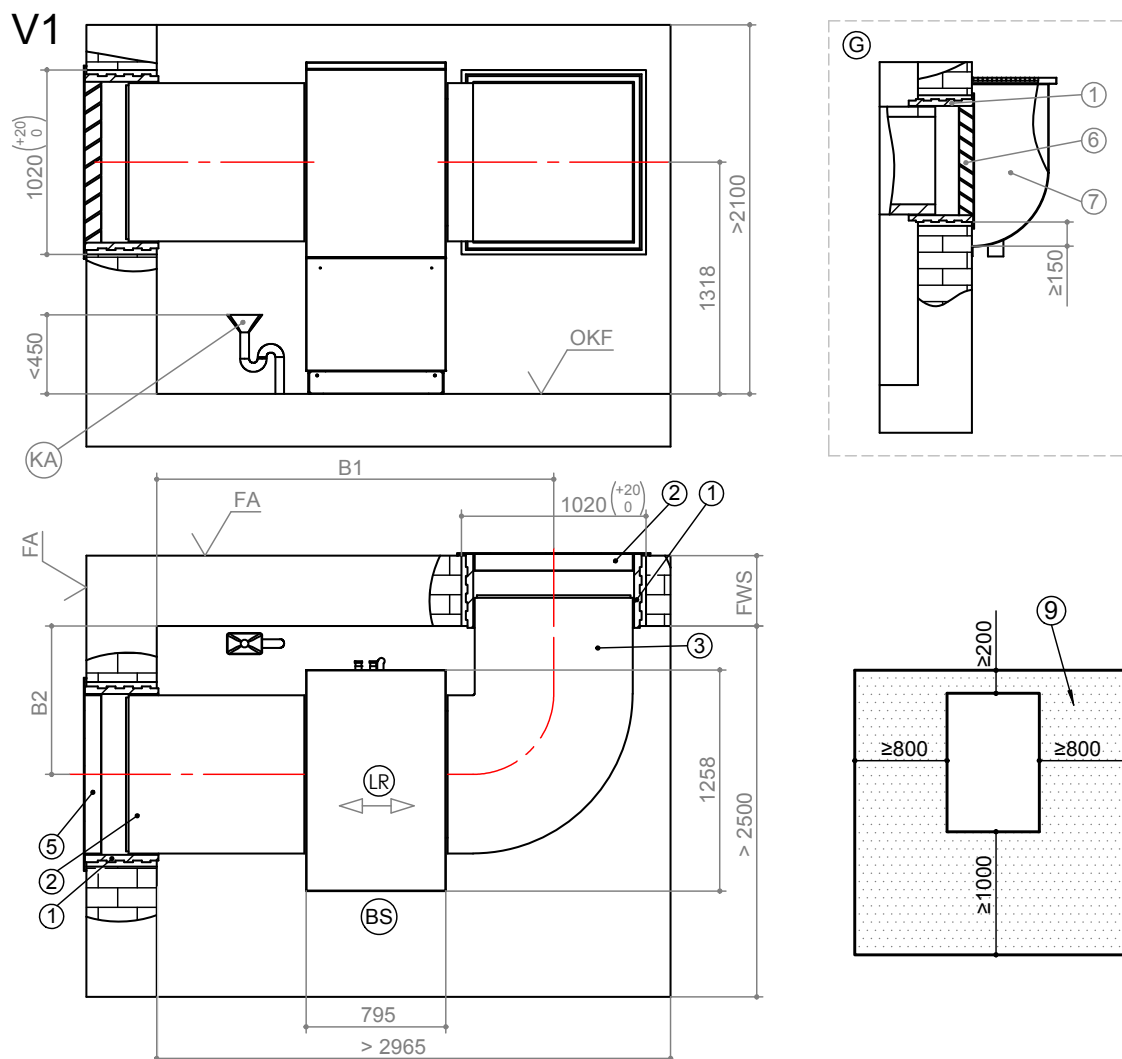

Legend: UK819337a-1

All dimensions in mm.

Item	Designation	Dim.
B1	With finished wall thickness 240 to 320	2340
	With finished wall thickness 320 to 400	2260
B2	With finished wall thickness 240 to 320	920
	With finished wall thickness 320 to 400	840

- V1 Version 1
- OKF Top edge of finished floor
- FA Finished outer façade
- LR Air direction
- BS Operator side
- FWS Finished wall thickness
- KA Condensate discharge
- G Section installation in light well

Tilting dimension of heat pumps = 2050mm

- | Item | Designation |
|------|--|
| 1 | Accessory: wall duct 1000x1000x420 |
| 2 | Accessory air duct 900x900x1000 |
| 3 | Accessory: air duct bend 900x1050x1450 |
| 5 | Installation above ground level
Accessory: weather guard 1045x1050 |
| 6 | Installation in light well
Accessory: rain guard 1045x1050 |
| 7 | provided by customer: light well with water drain min. exposed cross section 0,75m ² |
| 9 | Minimum clearance for service purposes
If the distances were to be reduced to the minimum dimension, the air ducts must be made shorter. This leads to a significant increase in the sound intensity level! |



Installation plan version 2

LW 251(L)

V2

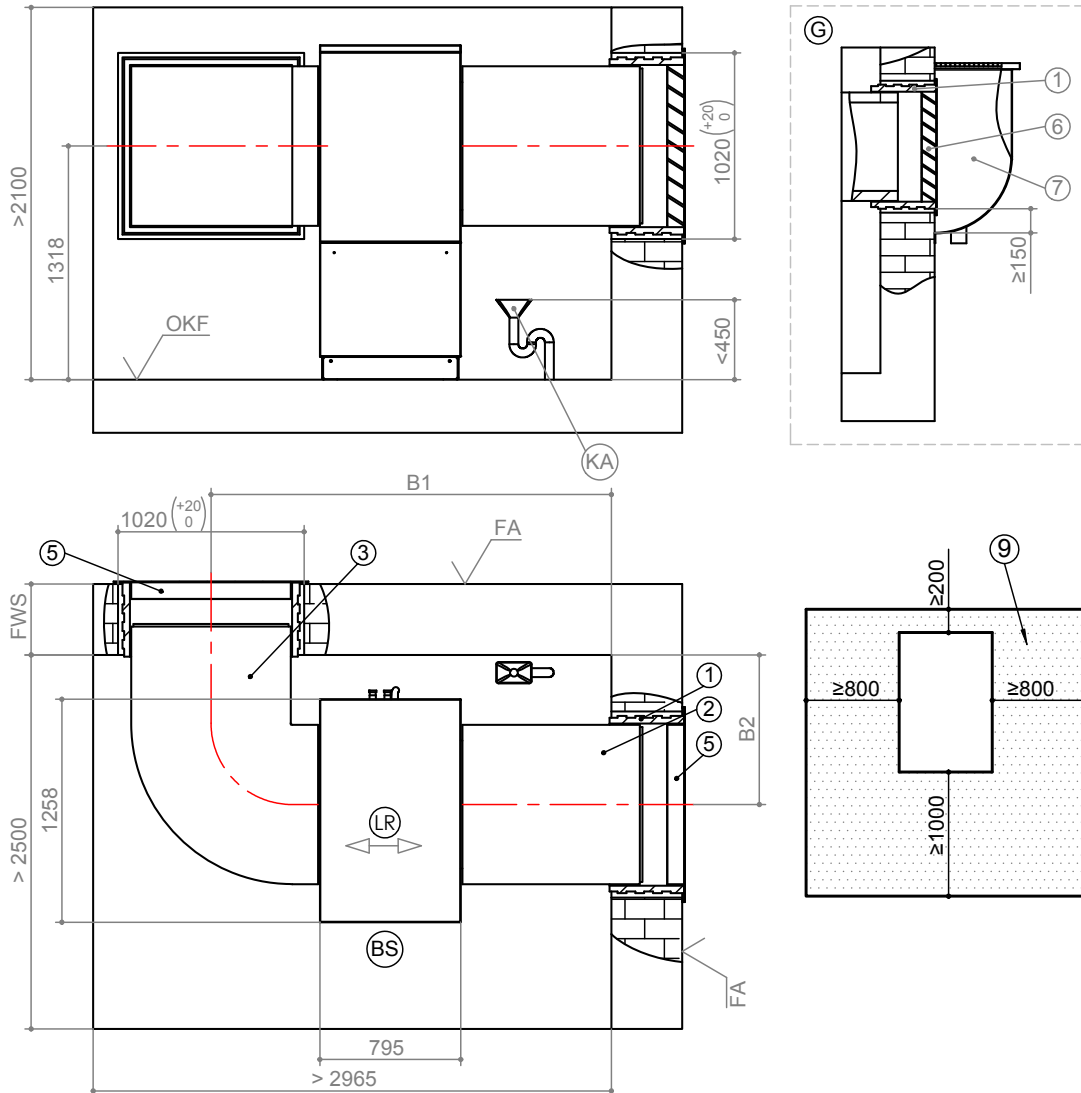

Legend: UK819337a-2

All dimensions in mm.

Item	Designation	Dim.
B1	With finished wall thickness 240 to 320	2340
	With finished wall thickness 320 to 400	2260
B2	With finished wall thickness 240 to 320	920
	With finished wall thickness 320 to 400	840

- V2 Version 2
- OKF Top edge of finished floor
- FA Finished outer façade
- LR Air direction
- BS Operator side
- FWS Finished wall thickness
- KA Condensate discharge
- G Section installation in light well

Item Designation

- 1 Accessory: wall duct 1000x1000x420
- 2 Accessory air duct 900x900x1000
- 3 Accessory: air duct bend 900x1050x1450
- 5 Installation above ground level
Accessory: weather guard 1045x1050
- 6 Installation in light well
Accessory: rain guard 1045x1050
- 7 provided by customer: light well with water drain min. exposed cross section 0,75m²
- 9 Minimum clearance for service purposes
If the distances were to be reduced to the minimum dimension, the air ducts must be made shorter. This leads to a significant increase in the sound intensity level!

Tilting dimension of heat pumps = 2050mm



LW 251(L)

Installation plan version 3

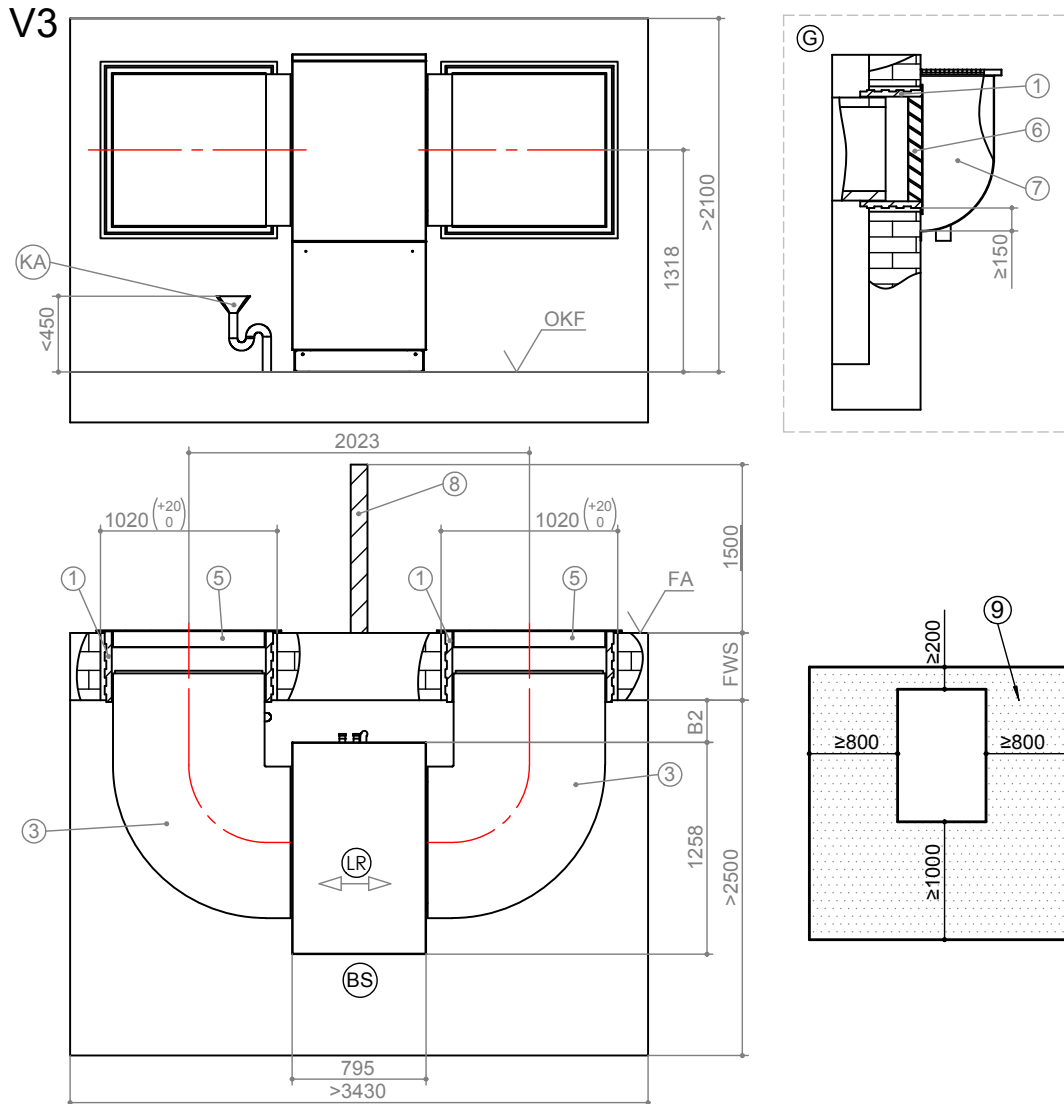

Legend: UK819337a-3

All dimensions in mm.

Item	Designation	Dim.
B2	With finished wall thickness 240 to 320	330
	With finished wall thickness 320 to 400	250
V3	Version 3	
OKF	Top edge of finished floor	
FA	Finished outer façade	
LR	Air direction	
BS	Operator side	
FWS	Finished wall thickness	
KA	Condensate discharge	
G	Section installation in light well	

Item	Designation
1	Accessory: wall duct 1000x1000x420
3	Accessory air duct bend 900x1050x1450
5	Installation above ground level Accessory: weather guard 1045x1050
6	installation in light well Accessory: rain guard 1045x1050
7	provided by customer: light well with water drain min. exposed cross section 0,75m ²
8	Ventilation separation: Depth 1000 Height by light well installation 1000 Height by installation above ground level 1700, 300 above weather guard
9	Minimum clearance for service purposes If the distances were to be reduced to the minimum dimension, the air ducts must be made shorter. This leads to a significant increase in the sound intensity level!

Tilting dimension of heat pumps = 2050mm



Installation plan version 4

LW 251(L)

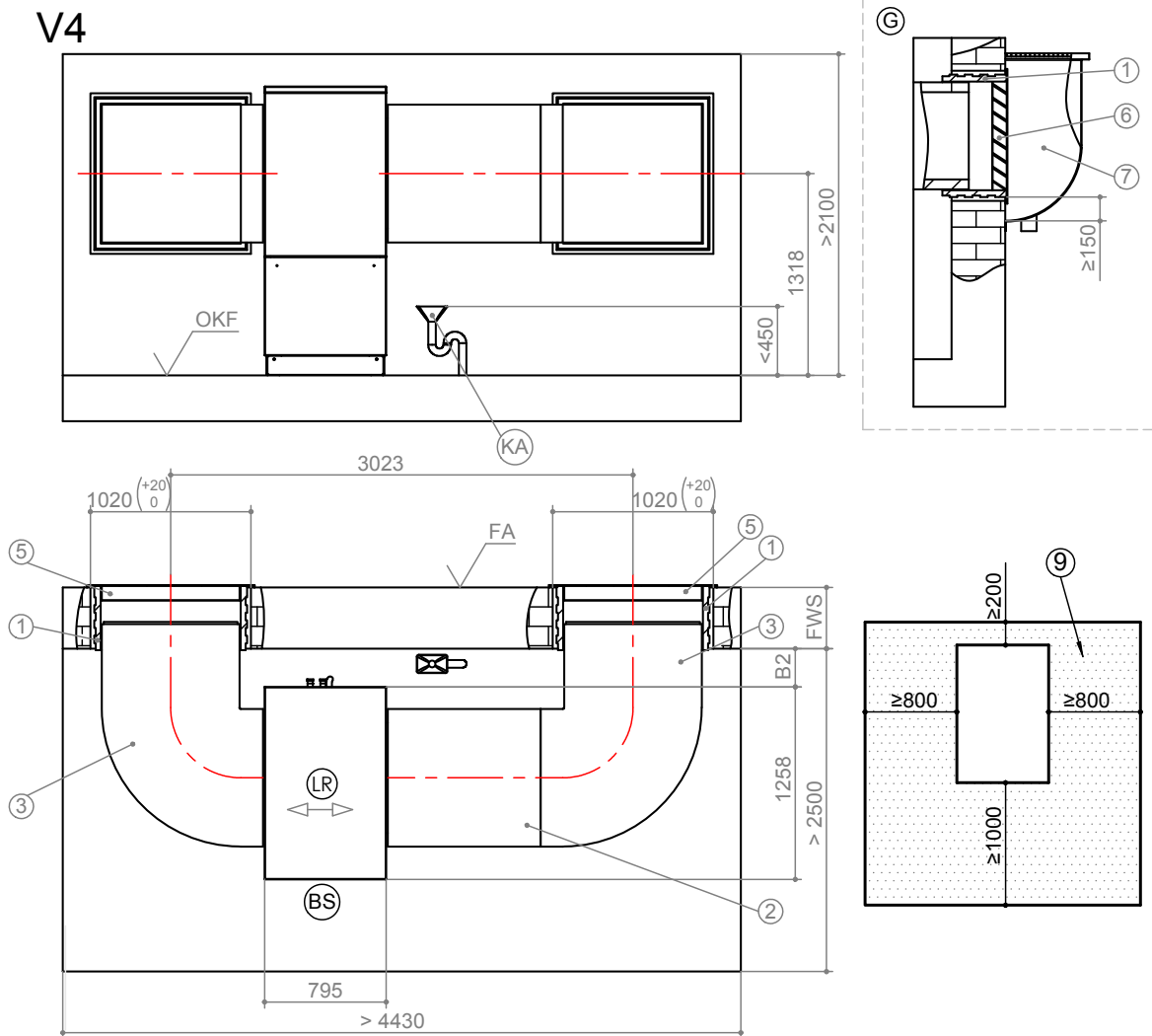

Legend: UK819337a-4

Item	Designation	Dim.
B2	With finished wall thickness 240 to 320	330
	With finished wall thickness 320 to 400	250

- V4 Version 4
- OKF Top edge of finished floor
- FA Finished outer façade
- LR Air direction
- BS Operator side

- FWS Finished wall thickness
- KA Condensate discharge
- G Section installation in light well

Tilting dimension of heat pumps = 2050mm

All dimensions in mm.

- | Item | Designation |
|------|--|
| 1 | Accessory: wall duct 1000x1000x420 |
| 2 | Accessory air duct 900x900x1000 |
| 3 | Accessory: air duct bend 900x1050x1450 |
| 5 | Installation above ground level
Accessory: weather guard 1045x1050 |
| 6 | installation in light well
Accessory: rain guard 1045x1050 |
| 7 | provided by customer: light well with water drain min. exposed cross section 0,75m ² |
| 9 | Minimum clearance for service purposes
If the distances were to be reduced to the minimum dimension, the air ducts must be made shorter. This leads to a significant increase in the sound intensity level! |



LW 140(L) – LW 251(L)

Coastal installation

IMPORTANT

The minimum distances necessary for correct and safe operation as well as any service work must be observed.

- ✓ Air intake on the side facing away from the coast / from the prevailing wind direction
- ✓ Air outlet not on the side facing the coast / prevailing wind direction

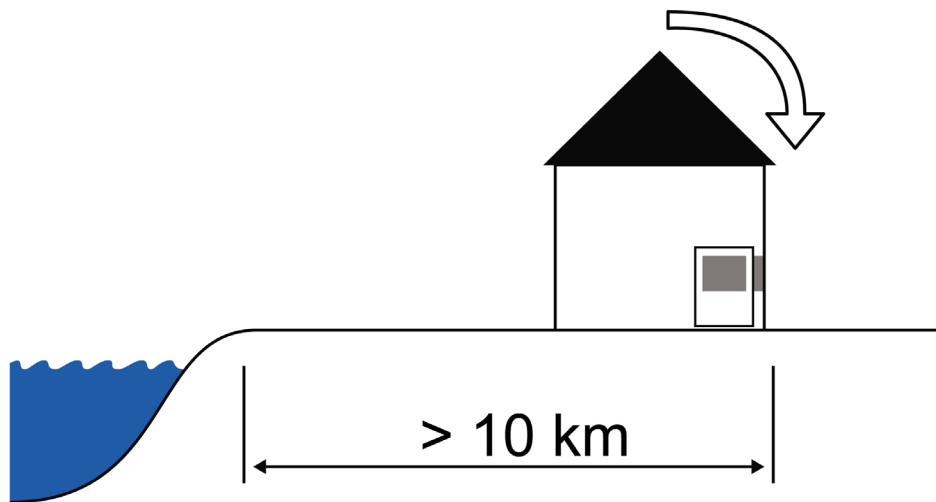



LW 140(L) – LW 251(L)

Row tank

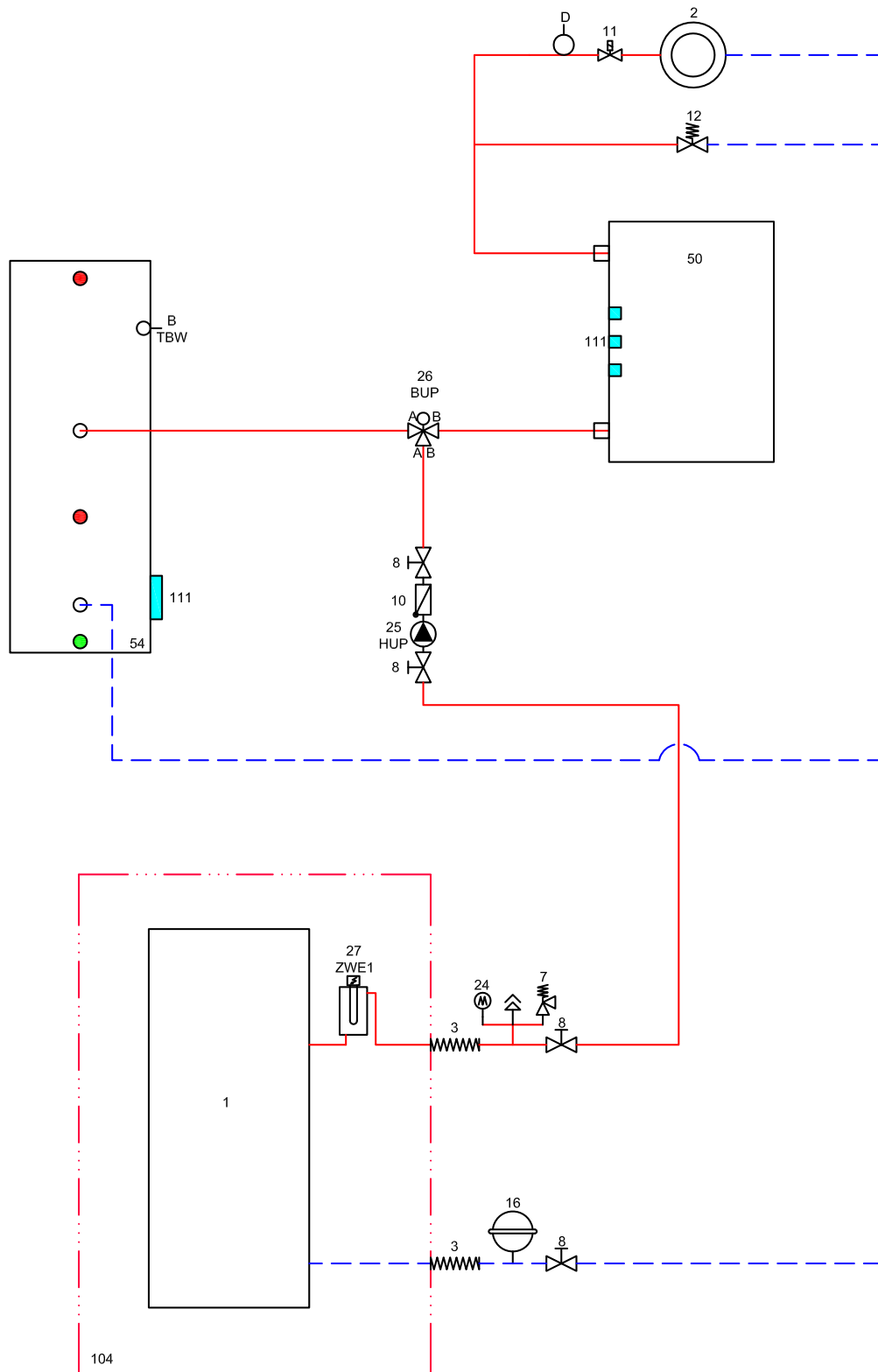



Separate buffer tank

LW 140(L) – LW 251(L)

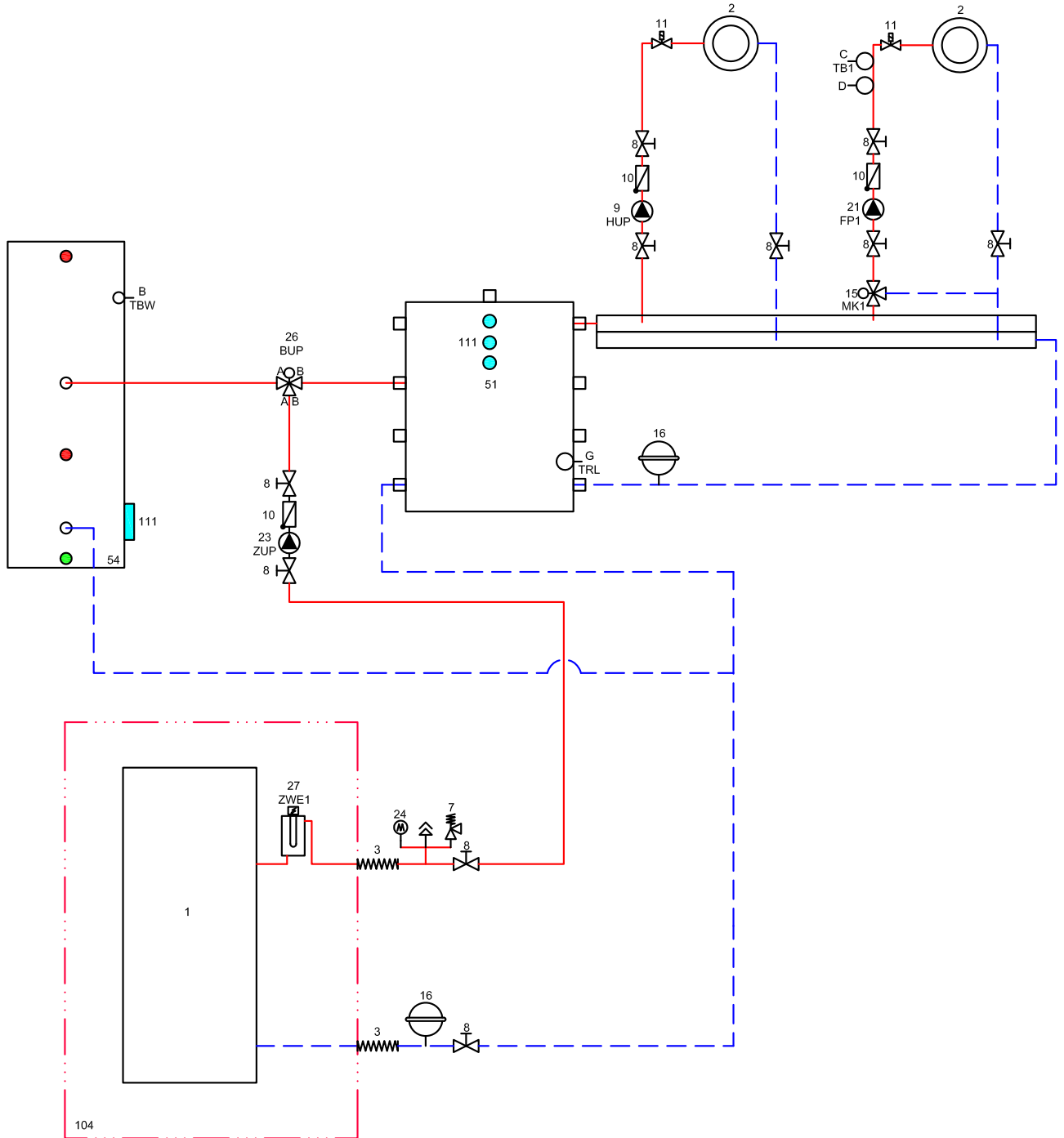



Legend hydraulic diagramm

1	Heat pump	51	Separation tank	TAVA	External sensor
2	Underfloor heating / radiators	52	Gas- or oil-boiler	TBW/B	Domestic hot water sensor
3	Vibration isolation	53	Wood boiler	TB1/C	Feedwater sensor mixer circuits 1
4	Sylomer strip machine underlay	54	Hot water cylinder	D	Floor temperature limiter
5	Closure and drainage	55	Brine pressure switch	TRL/G	Sensor external return
6	Expansion vessel packing list	56	Swimming pool heat exchanger	STA	Line pressure regulator valve
7	Safety valve	57	Geothermal heat exchanger	TRL/H	Sensor return (hydraulic module, dual)
8	Closure	58	Ventilation system		
9	Heating circulation pump	59	Plate heat exchanger	79	Motor valve
10	Non return valve/ one way valve	61	Cooling cylinder	80	Mixing valve
11	Individual room regulation	65	Compact distributor	81	Split heat pump outdoor unit
12	Overflow valve	66	Fancoils	82	Split heat pump indoor unit
13	Steamtight insulation	67	Solar/ service water cylinder	83	Circulation pump
14	Service water circulation pump	68	Solar/ service water cylinder	84	Switching valve
15	Mixer circuit three-way mixer (MK1 discharge)	69	Multifunction tank	113	Connection 2nd heat generator
16	Expansion vessel supplied by customer	71	Dual hydraulic module	BT1	Outdoor temperature sensor
18	Heating rod (heating)	72	Buffer tank wall mounted	BT2	Flow temperature sensor
19	Mixer circuit four-way mixer (MK1 charge)	73	Pipe lead-in	BT3	Return temperature sensor
20	Heating rod (SW)	74	Ventower	BT6	Domestic hot water temperature sensor
21	Mixer circuit circulation pump (FP1)	75	Scope of delivery, hydraulic tower, dual	BT12	Flow temperature liquefier
23	Feed circulating pump (reconnect the integrated circulating pump in the heat pump)	76	Fresh water station	BT19	Temperature sensor immersion heater
24	Manifold	77	Scope of supply water/water booster	BT24	Temperature sensor 2nd heat generator
25	Heating circulation pump	78	Accessories water/water booster optional		
26	Switching valve (heating/service water)(B = normally open)				
27	Heating element				
28	Brine circulation pump				
29	Dirt-trap 0.6 mm mesh				
30	Spill-tray for brine mix				
31	Wall breakthrough	100	Room thermostat for cooling (optional)	15	Mixer circuit three-way mixer (MK2-3 discharge)
32	Inlet pipe	101	Controls supplied by customer	17	Temperature difference regulator
33	Brine manifold	102	Dew-point monitor (optional)	19	Mixer circuit four-way mixer (MK2 charge)
34	Ground collector	103	Room thermostat for reference space in packing list	21	Mixer circuit circulation pump (FP2-3)
35	Ground slinkies	104	Supply heat pump	22	Swimming pool circulating pump
36	Groundwater spring pump	105	Cooling circuit module box removeable for installation	44	Three-way mixer valve (cooling function MK2)
37	Wall bracket	106	Specific glycole mixture	47	Changeover valve swimming bath preparation(B = normally open)
38	Flow switch	107	Scald protection / thermostatic mixer valve	60	Changeover valve cooling operation(B = normally open)
39	Suction well	108	Solar pump assembly	62	Heat meter (optional)
40	Inverted well	109	Overflow valve must be closed	63	Changeover valve solar circuit(B = normally open)
41	Rinse fitting heating circuit	110	Packing list hydraulic tower	64	Cooling circulation pump
42	Circulation pump	111	Mounting for additional heating element	70	Solar separation module
43	Brine / Water heat exchanger (cooling function)	112	Minimum distance to thermal decoupling of the mixing valve	TB2-3/C	Feedwater sensor mixer circuits 2-3
44	Three-way mixer valve (cooling function MK1)			TSS/E	Sensor, temperature difference control (low temperature)
45	Cap valve			TSK/E	Sensor, temperature difference control (high temperature)
46	Filler and drainage valve			TEE/F	Sensor external energy source
48	Domestic hot water charging pump				
49	Direction of groundwater flow				
50	Buffer storage				

Comfort board / Expansion board:

15	Mixer circuit three-way mixer (MK2-3 discharge)
17	Temperature difference regulator
19	Mixer circuit four-way mixer (MK2 charge)
21	Mixer circuit circulation pump (FP2-3)
22	Swimming pool circulating pump
44	Three-way mixer valve (cooling function MK2)
47	Changeover valve swimming bath preparation(B = normally open)
60	Changeover valve cooling operation(B = normally open)
62	Heat meter (optional)
63	Changeover valve solar circuit(B = normally open)
64	Cooling circulation pump
70	Solar separation module
TB2-3/C	Feedwater sensor mixer circuits 2-3
TSS/E	Sensor, temperature difference control (low temperature)
TSK/E	Sensor, temperature difference control (high temperature)
TEE/F	Sensor external energy source

Important notice!

These hydraulic diagrams are schematic representations and are for assistance only. They do not relieve of the obligation to carry out appropriate planning! They do not include all necessary shut-off valves, ventilator fittings or safety devices. These must be incorporated in accordance with the standards and regulations applicable to the respective installation. All country-specific standards, laws and regulations must be observed! The tubes have to be dimensioned according to the nominal volume flow of the heat pump resp. the free pressing of the integrated circulating pump. For detailed information and advice please contact our local sales partner!



LW 140(L) – LW 251(L)

Terminal diagram

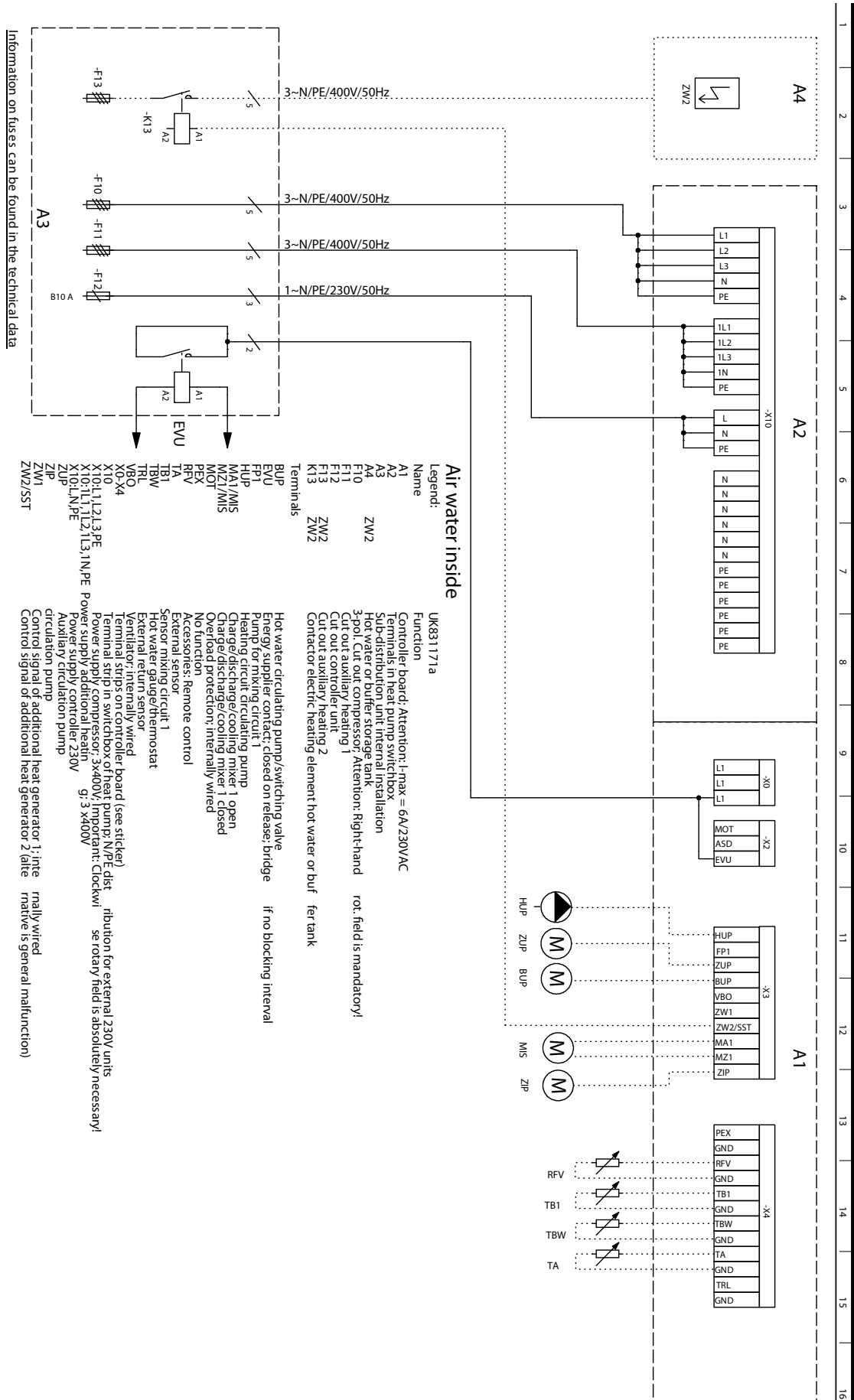



LW 140(L)

Circuit diagram 1/3

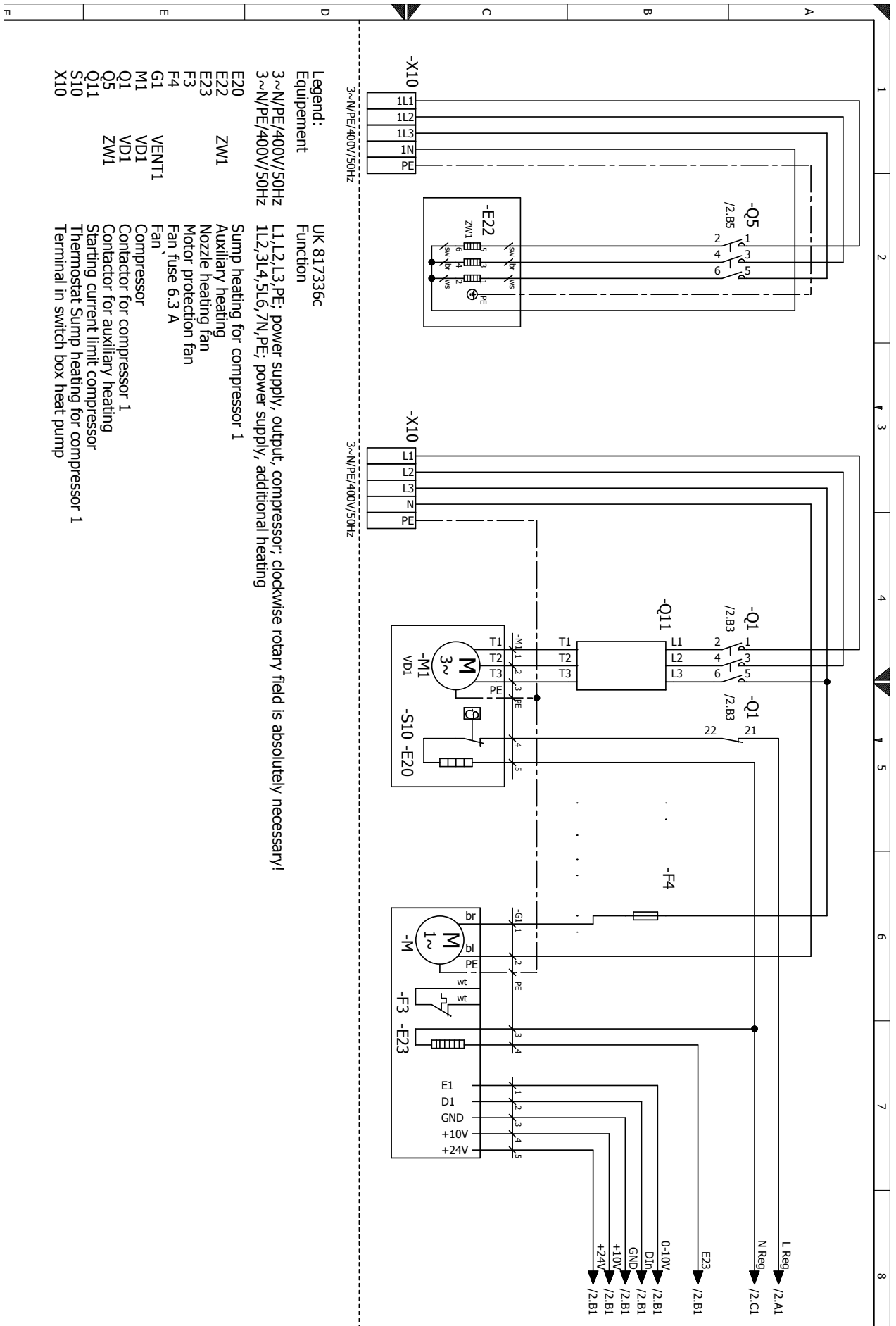



LW 140(L)

Circuit diagram 3/3

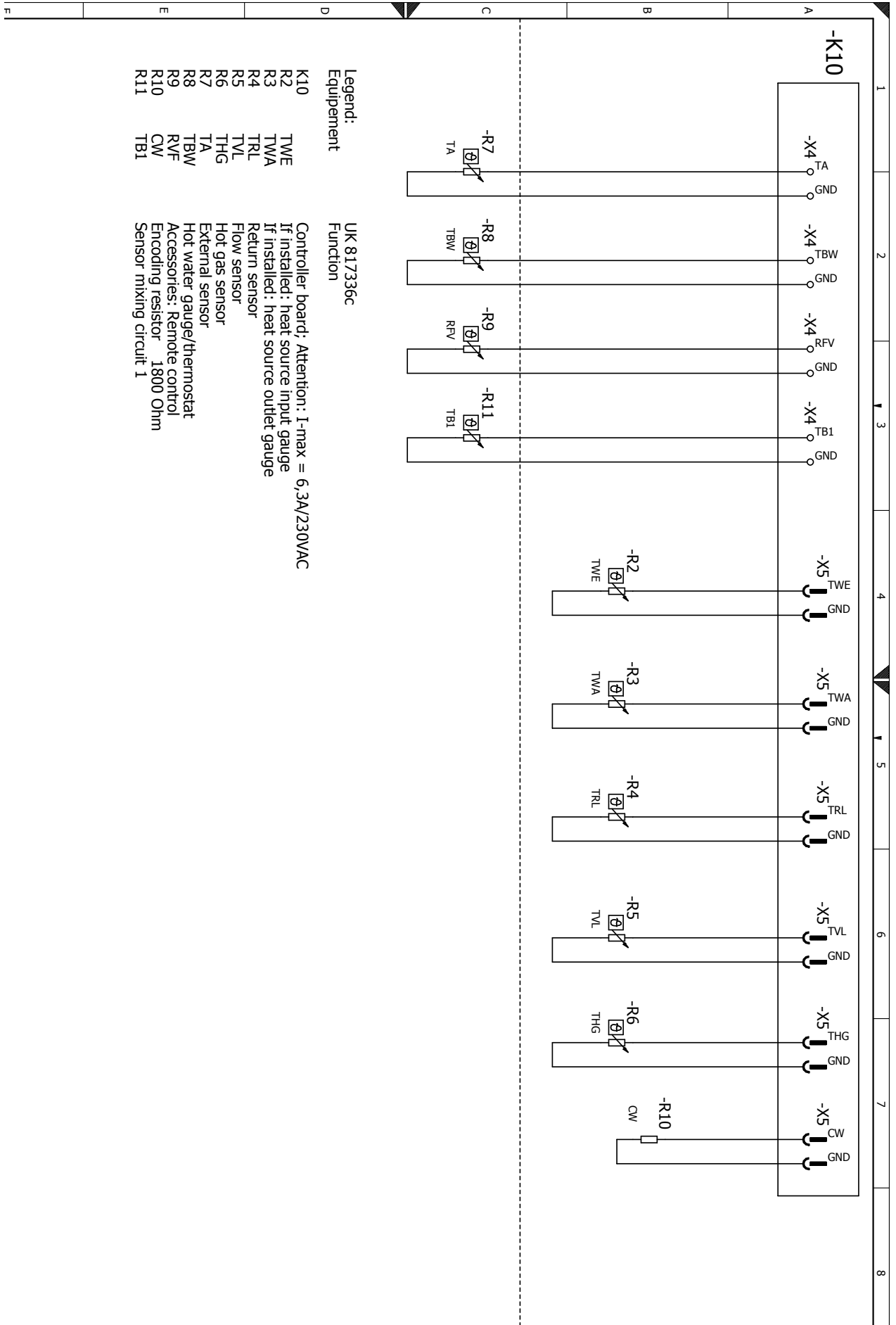



LW 180(L)

Circuit diagram 3/3

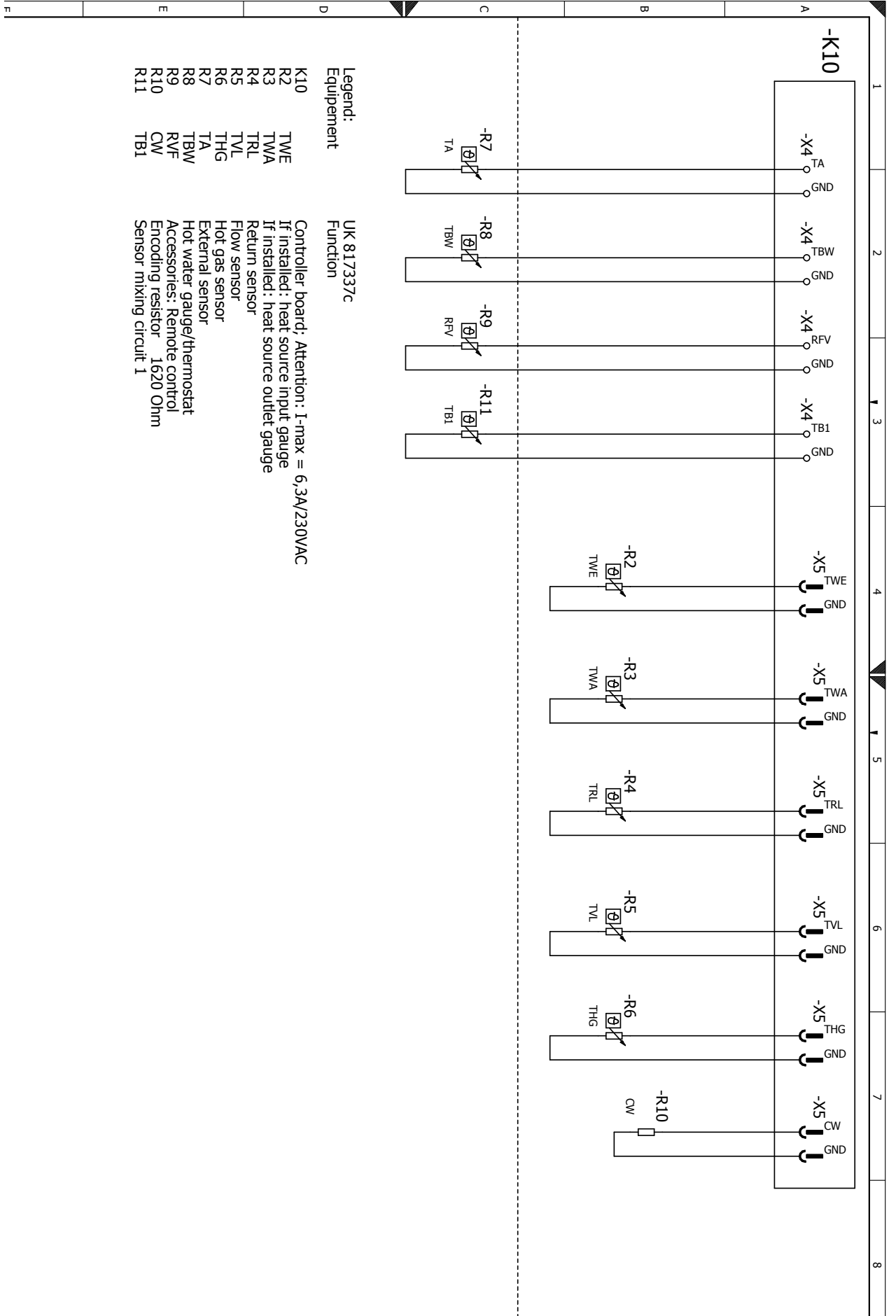



LW 251(L)

Circuit diagram 1/3

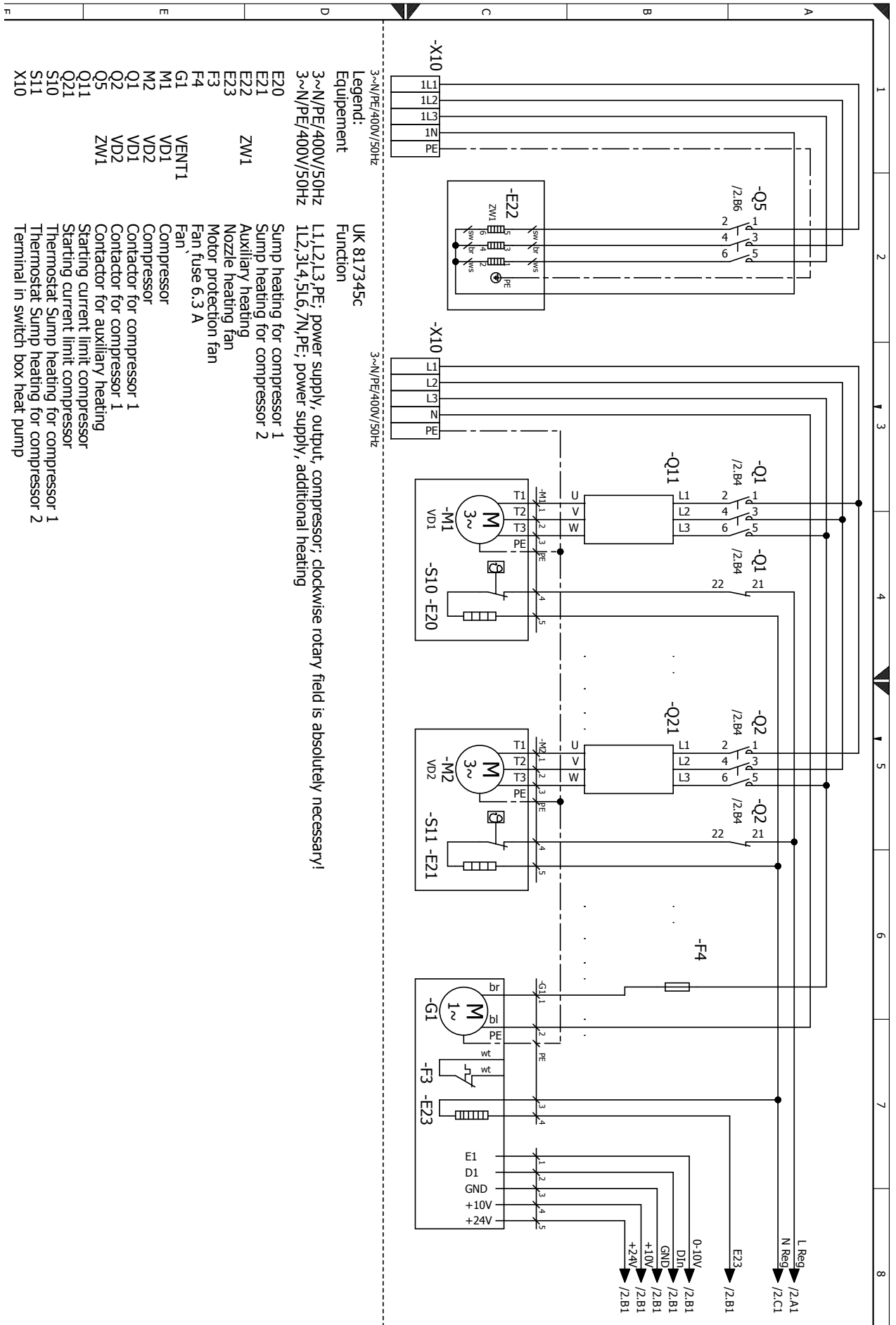



LW 251(L)

Circuit diagram 3/3

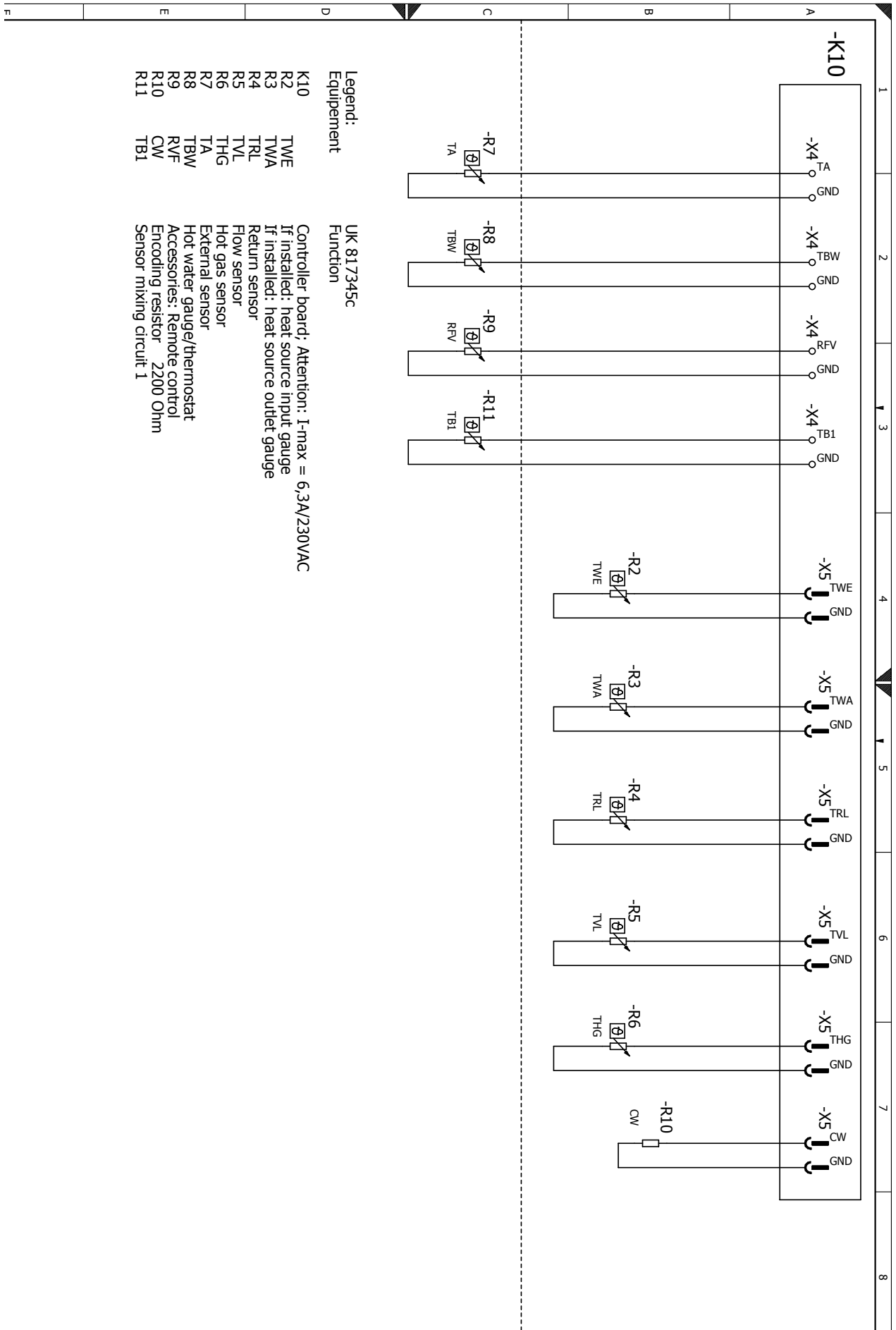



EC Declaration of Conformity in accordance with the EC Machinery Directive 2006/42/EC, Annex II A



The undersigned confirms that the following designated device(s) as designed and marketed by us fulfill the standardized EC directives, the EC safety standards and the product-specific EC standards. In the event of modification of the device(s) without our approval, this declaration shall become invalid.

Designation of the device(s)

Heat Pump



Unit model	Number	Unit model	Number
LW 71A	100 540	LW 101	100 530
LW 81A	100 541	LW 121	100 531
LW 101A	100 542	LW 140	100 532
LW 121A	100 543	LW 140L	100 533
LW 140A	100 544	LW 180	100 534
LW 180A	100 545	LW 180L	100 535
LW 251A *	100 546	LW 251 *	100 536
LW 310A *	100 547	LW 251L *	100 537
LW 100H-A	100 587	LW 310 *	100 538
LW 180H-A	100 589	LW 310L *	100 539
LW 100H	100 586	LW 380/1 *	100 474
LW 180H	100 588	LW 380L/1 *	100 475
LW 160H-A/V	100 625	LW 160H/V	100 623
LW 160HL/V	100 624		

EC Directives

2006/42/EG 2009/125/EG
2006/95/EG 2010/30/EU
2004/108/EG
*97/23/EG
2011/65/EG

* Pressure equipment component

Category II
Module A1
Designated position:
TÜV-SÜD
Industrie Service GmbH (Nr.:0036)

Standardized EN

EN 378 EN 349
EN 60529 EN 60335-1/-2-40
EN ISO 12100-1/2 EN 55014-1/-2
EN ISO 13857 EN 61000-3-2/-3-3

Company:

ait-deutschland GmbH
Industrie Str. 3
93359 Kasendorf
Germany

Place, date: Kasendorf, 14.12.2015

Signature:

UK818154e

Jesper Stannow
Head of Heating Development



ait-deutschland GmbH
Industriestraße 3
D-95359 Kasendorf

E info@alpha-innotec.de
W www.alpha-innotec.de



alpha innotec – an ait-deutschland GmbH brand