

OPERATING MANUAL LWCV - SERIES

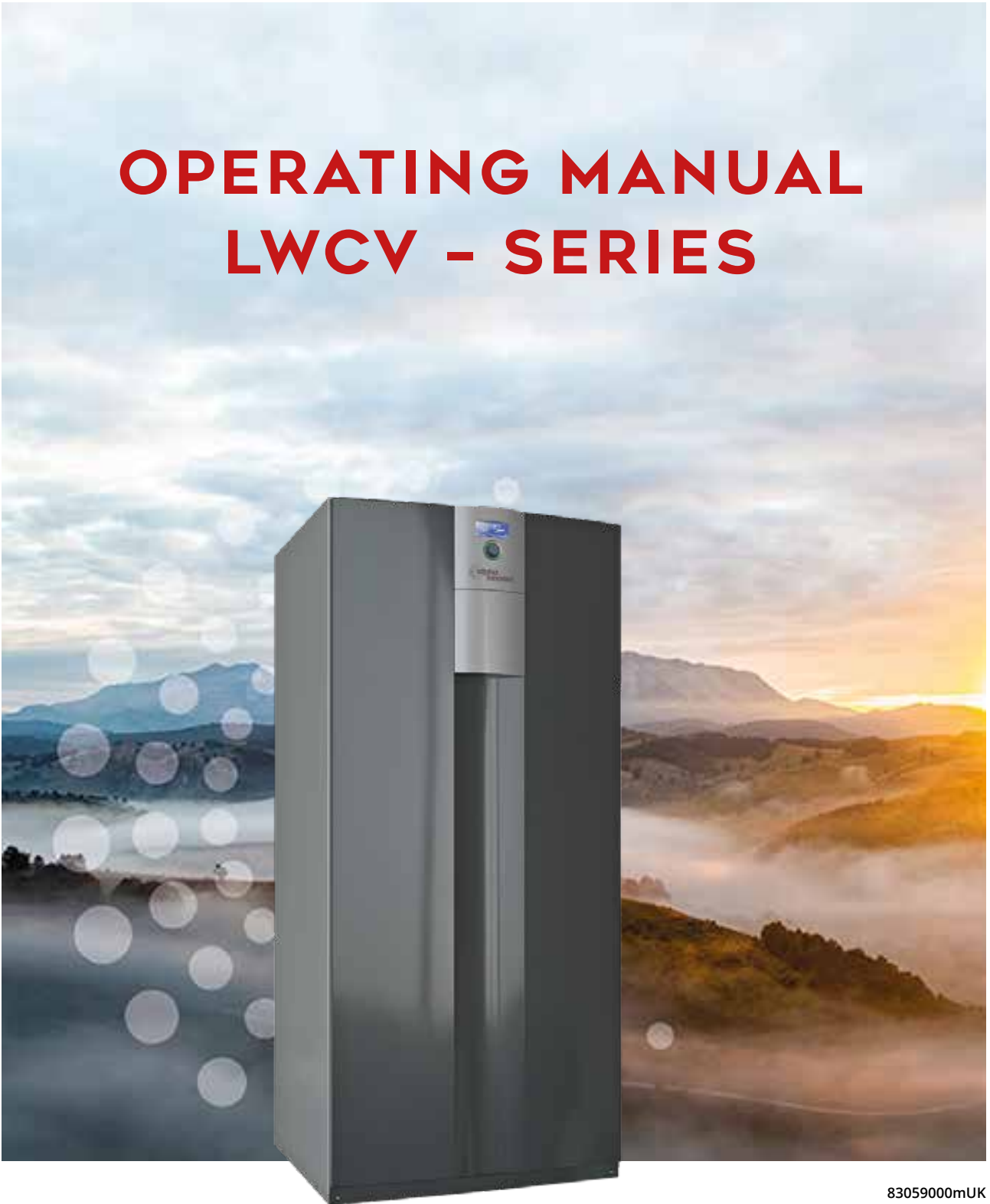

83059000mUK

UK

Air/Water heat pumps
Indoor installation



Table of contents

1	About this operating manual	3	9	Flushing, filling and venting	19
1.1	Validity	3	9.1	Heating water quality	19
1.2	Reference documents	3	9.2	Flush and fill the heating and domestic hot water charging circuit	19
1.3	Symbols and markings	3	10	Insulate hydraulic connections	20
1.4	Contact	4	11	Set the overflow valve	21
2	Safety	4	12	Commissioning	22
2.1	Intended use	4	13	Maintenance	22
2.2	Personnel qualifications	4	13.1	Basic principles	22
2.3	Personal protective equipment	4	13.2	Maintenance after commissioning	22
2.4	Residual risks	5	13.3	Maintenance as required	22
2.5	Disposal	5	13.4	Clean and flush condenser	23
2.6	Avoid damage to property	5	13.5	Yearly maintenance	23
3	Description	6	14	Faults	24
3.1	Delivery condition	6	15	Dismantling and Disposal	24
3.2	Layout	6	15.1	Dismantling	24
3.3	Accessories	8	15.2	Disposal and recycling	24
3.4	Function	9	15.2.1	Buffer battery	24
4	Operation and care	9	Technical data / Scope of supply	25	
4.1	Energy and environmentally aware operation	9	Performance curves	26	
4.2	Maintenance	9	LWCV 82R1/3	26	
5	Delivery, storage, transport and installation	10	LWCV 122R3	28	
5.1	Scope of supply	10	Dimensional drawings	30	
5.2	Storage	10	LWCV	30	
5.3	Unpacking and transport	11	Connections ball valves	32	
5.4	Installation	13	Control panel	32	
5.5	Installation of air ducting	14	Installation plans	33	
5.6	Attach side walls, rear wall and cover	14	Coastal installation	41	
6	Hydraulic installation	15	Hydraulic integration	42	
6.1	Establish the hydraulic connection between the heat pump module and the compact module	15	Keys hydraulic integration	44	
6.2	Connect the unit to the heating circuit ...	15	Terminal diagrams	46	
6.3	Condensate connection	16	LWCV	46	
7	Electrical installation	17	Terminal diagram, mains connection LWCV 82R1/3 1~230V + electric heating element 3~400V	48	
7.1	Establish the electrical connection between the heat pump module and the compact module	17	Terminal diagram, mains connection LWCV 82R1/3 1~230V + electric heating element 1~230V	49	
7.2	Connect the electrical cables	17	Terminal diagram, mains connection LWCV 122R3 3~400V + electric heating element 3~400V	50	
8	Installing the control panel	18	Circuit diagrams	51	
8.1	Mount the control panel on the wall and connect	18	LWCV Compact modul	51	
8.2	Connections of the control panel	19	LWCV 82R1/3 Heat pump module	55	
8.3	Operate the controller via a PC /network	19	LWCV 122R3 Heat pump module	60	



1 About this operating manual

This operating manual is part of the unit.

- ▶ Before working on or with the unit read the operating manual carefully and follow it for all activities at all times, especially the warnings and safety instructions.
- ▶ Keep the operating manual to hand at the unit and hand over to the new owner if the unit changes hands.
- ▶ If you have any questions or anything is unclear, ask the local partner of the manufacturer or the factory's customer service.
- ▶ Note and follow all reference documents.

1.1 Validity

This operating manual refers solely to the unit identified by the nameplate (→ "Nameplates", page 8).

1.2 Reference documents

The following documents contain additional information to this operating manual:

- Planning & design manual, hydraulic integration
- Operating manual of the heating and heat pump controller
- Brief description of the heat pump controller
- Operating manual of the expansion board (accessories)
- Log book

1.3 Symbols and markings

Identification of warnings

Symbol	Meaning
	Safety-relevant information. Warning of physical injuries.
	Safety-relevant information. Warning of physical injuries. Flammable materials / flammable (primary) refrigerant
	Safety-relevant information. Warning of physical injuries. Flammable materials / flammable (primary) refrigerant

Symbol	Meaning
	Safety-relevant information. Warning of physical injuries. Danger of fatal injury due to electric current.
DANGER	Indicates an imminent danger resulting in severe injuries or death.
WARNING	Indicates a potentially dangerous situation, which can result in severe injuries or death.
CAUTION	Indicates a potentially dangerous situation, which can result in moderate or minor injuries.
IMPORTANT	Indicates a potentially dangerous situation, which can result in material damage.

Symbols in the document

Symbol	Meaning
	Information for specialist
	Information for operator
✓	Prerequisite for an action
▶	Procedural instructions: Single-step instruction for action
1., 2., 3., ...	Procedural instructions: Numbered step within a multi-step instruction for action. Adhere to the given sequence.
	Additional information, e.g. a note for making work easier, information on standards
→	Reference to further information elsewhere in the operating manual or in another document
•	List
	Secure connections against twisting



1.4 Contact

Addresses for purchasing accessories, for service cases or for answers to questions about the unit and this operating manual can be found on the internet and are kept up-to-date:

- www.alpha-innotec.com

2 Safety

Only use the unit if it is in proper technical condition and only use it as intended, safely and aware of the hazards, and follow this operating manual.

2.1 Intended use

The unit is designed for household use and is solely intended for the following functions:

- Heating
- Domestic hot water preparation (optional, with accessories)
- Cooling, reversible to 18°C flow temperature
- ▶ Proper use includes complying with the operating conditions (→ “Technical data / Scope of supply”, page 25) and the operating manual and noting and following the reference documents.
- ▶ When using the local regulations note: laws, standards, guidelines, directives.

All other uses of the unit are not as intended.

2.2 Personnel qualifications

The operating manuals supplied with the product are intended for all users of the product.

The operation of the product via the heating and heat pump control and work on the product which is intended for end customers / operators is suitable for all age groups of persons who are able to understand the activities and the resulting consequences and can carry out the necessary activities.

Children and adults who are not experienced in handling the product and do not understand the necessary activities and the resulting consequences must be instructed and, if necessary, supervised by persons experienced in handling the product and who are responsible for safety.

Children must not play with the product.

The product may only be opened by qualified personnel.

All procedural instructions in this operating manual are solely directed at qualified specialist personnel.

Only qualified, skilled personnel is able to carry out the work on the unit safely and correctly. Interference by unqualified personnel can cause life-threatening injuries and damage to property.

- ▶ Ensure that the personnel is familiar with the local regulations, especially those on safe and hazard-aware working.
- ▶ Ensure that the personnel are qualified to handle refrigerant.
- Work on the refrigerating circuit may only be carried out by qualified personnel with appropriate qualifications for refrigeration system installation.
- Work on the electrics and electronics may only be carried out by electrical technicians.
- Any other work on the system may only be carried out by qualified personnel (heating installer, plumbing installer).

During the warranty and guarantee period, service work and repairs may only be carried out by personnel authorised by the manufacturer.

2.3 Personal protective equipment

During transport and work on the unit, there is a risk of cuts due to the sharp edges of the unit.

- ▶ Wear cut-resistant protective gloves.

During transport and work on the unit, there is a risk of foot injuries.

- ▶ Wear safety shoes.

When working on liquid-conveying lines, there is a risk of injury to the eyes due to leakage of liquids.

- ▶ Wear safety goggles.



2.4 Residual risks

Electric shock

Components in the unit are live with life-threatening voltage. Before working on the unit:

- ▶ Disconnect unit from power supply.
- ▶ Protect unit against being switched back on again.
- ▶ Residual voltage at the inverter. Wait 90 seconds before opening the device.

Existing earthing connections within housings or on mounting plates must not be altered. If this should nevertheless be necessary in the course of repair or assembly work:

- ▶ Restore earthing connections to their original condition after completion of the work.

Injury due to moving parts

- ▶ Switch device on only with air ducts and weather and/or rain louvres fitted.

Injuries caused by high temperatures

- ▶ Before working on the unit, let it cool down.

Safety instructions and warning symbols

- ▶ Observe the safety instructions and warning symbols on the packaging and on and in the unit.

Injuries and environmental damage due to refrigerant

The unit contains refrigerant that is hazardous to health and the environment. If (primary) refrigerant leaks from the unit, there is a risk of an explosion:

1. Switch off unit.
2. Thoroughly ventilate installation area.
3. Notify authorised after sales service.

2.5 Disposal

Environmentally hazardous substances

Improper disposal of environmentally hazardous substances (e.g. refrigerant, compressor oil) damages the environment:

- ▶ Collect substances safely.
- ▶ Dispose of the substances in an environmentally-friendly manner according to the local regulations.

2.6 Avoid damage to property

The ambient air at the heat pump installation site, as well as the air drawn in as a heat source, must not contain any corrosive constituents!

Constituents such as

- Ammonia
- Sulphur
- Chlorine
- Salt
- Sewer gasses, flue gasses

can cause damage to the heat pump, which could lead to the complete failure / destruction of the heat pump!

Cooling

If the heating surfaces are used for heating and cooling, the control valves must be suitable for heating and cooling.

By cooling with low flow temperatures, condensate can be expected to form on the heat distribution system as the temperature falls below the dew point. If the heat distribution system is not designed for these operating conditions, it must be protected by appropriate safety devices, e.g. dew point monitor (purchasable accessory).

Decommissioning / draining the heating

If the system / heat pump is decommissioned or emptied, after it has been filled already, it is necessary to ensure that the condenser and any heat exchangers present have been completely emptied in the event of frost. Residual water in heat exchangers and condensers can result in damage to components.

- ▶ Empty system and condenser completely, open vent valves.
- ▶ Blast out with compressed air if necessary.



Improper action

Requirements for minimum scale and corrosion damage in hot water heating systems:

- Proper planning, design and commissioning
- Closed system with regard to corrosion
- Integration of an adequately dimensioned pressure maintaining device
- Use of demineralised heating water (VE water) or water corresponding to the VDI 2035 norm
- Regular servicing and maintenance

If a system is not planned, designed, started up and operated in accordance with the given requirements, there is a risk that the following damage and faults will occur:

- Malfunctions and the failure of components, e.g. pumps, valves
 - Internal and external leaks, e.g. from heat exchangers
 - Cross-section reduction and blockages in components, e.g. heat exchanger, pipes, pumps
 - Material fatigue
 - Gas bubbles and gas cushion formation (cavitation)
 - Negative effect on heat transfer, e.g. formation of coatings, deposits, and associated noises, e.g. boiling noises, flow noises
- Note and follow the information in this operating manual for all work on and with the unit.

Unsuitable quality of the fill and make-up water in the heating circuit

The efficiency of the system and the life of the heat generator and the heating components depend decisively on the quality of the heating water.

If the system is filled with untreated drinking water, calcium and magnesium precipitate as mineral scale. Limescale deposits form on the heat transfer surfaces of the heating. The efficiency drops and energy costs rise. In extreme cases the heat exchangers are damaged.

- Fill the system with deionised heating water (VE water) or with water corresponding to the VDI 2035 norm only (low-salt operation of the system).

3 Description

3.1 Delivery condition

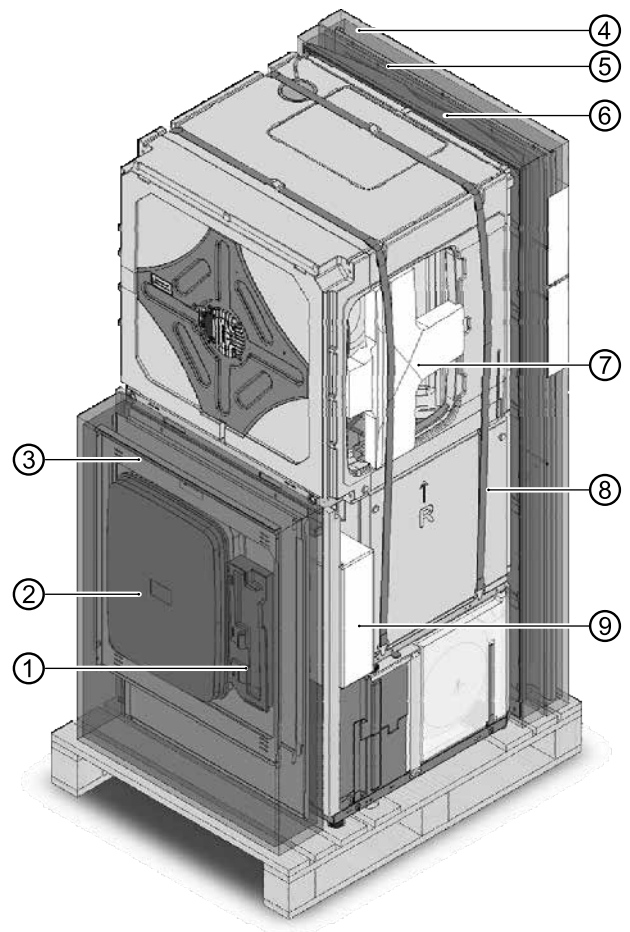

- 1 Switch box cover
- 2 Blind cover and louvre grille
- 3 Side wall (2-piece) and cover
- 4 Rear wall
- 5 Side wall (complete)
- 6 Front wall
- 7 Supporting crosspiece (left and right; only remove after positioning at the final installation site!)
- 8 Lashing straps (with grip openings)
- 9 Transport box for accompanying parts: Regulator control panel, safety module, shut-off valves, connection tube, operating manual

3.2 Layout



NOTE

This section essentially names the components relevant for fulfilling the tasks described in this operating manual.

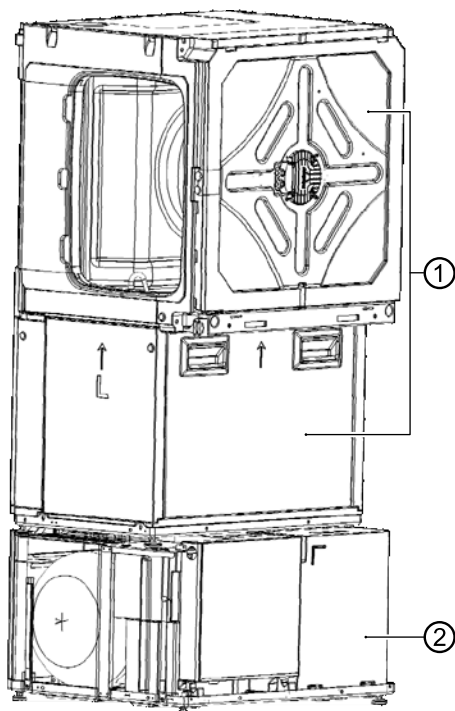

- 1 Heat pump module
- 2 Compact module

The compact module

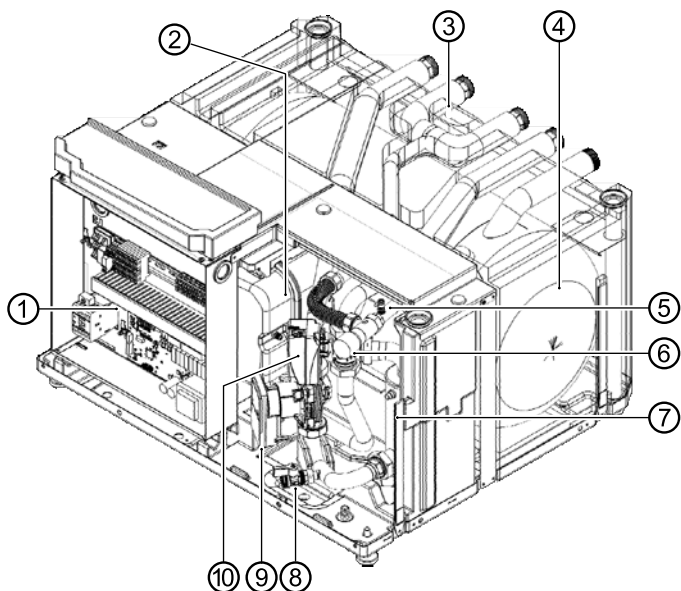

- 1 Electrical switch box, fold-out
- 2 Expansion tank
- 3 Return sensor
- 4 Buffer tank
- 5 Vent valve
- 6 Overflow valve
- 7 Electric heating element
- 8 Fill and drain valve
- 9 Heating circuit / domestic hot water circulation pump
- 10 Heating circuit / domestic hot water switching valve

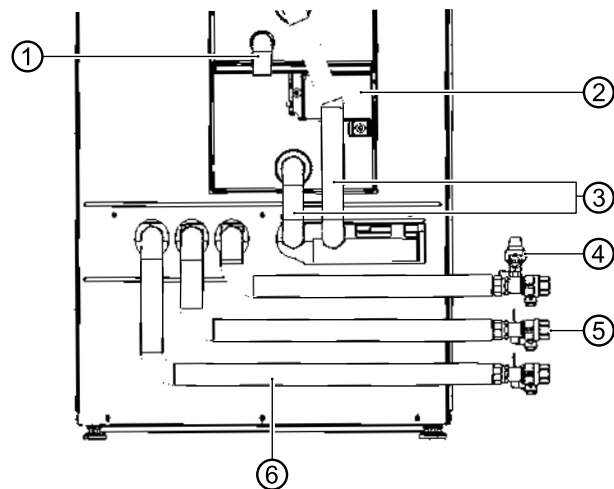

- 1 Condensate nozzle
- 2 Cover for electrical connections
- 3 Pre-finished connection kit, heat pump module / compact module
- 4 Manometer, safety valve
- 5 3 x ball valves with flushing device
- 6 3 x copper piping for hydraulic connection to the heating system

The heat pump module

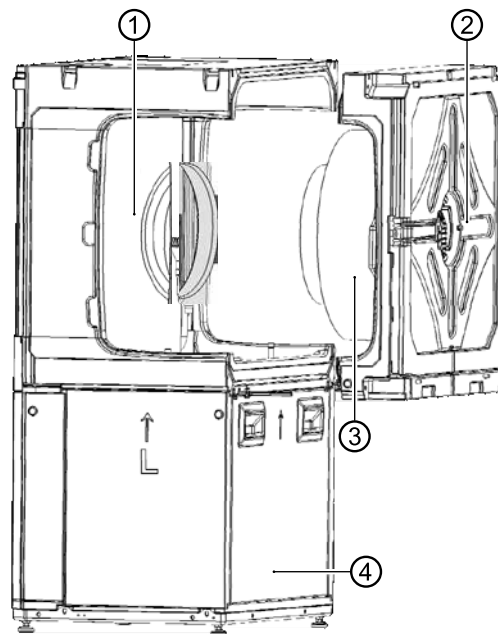

- 1 Evaporator module
- 2 Fan module
- 3 Fan
- 4 Refrigerant circuit module



The refrigerant circuit module

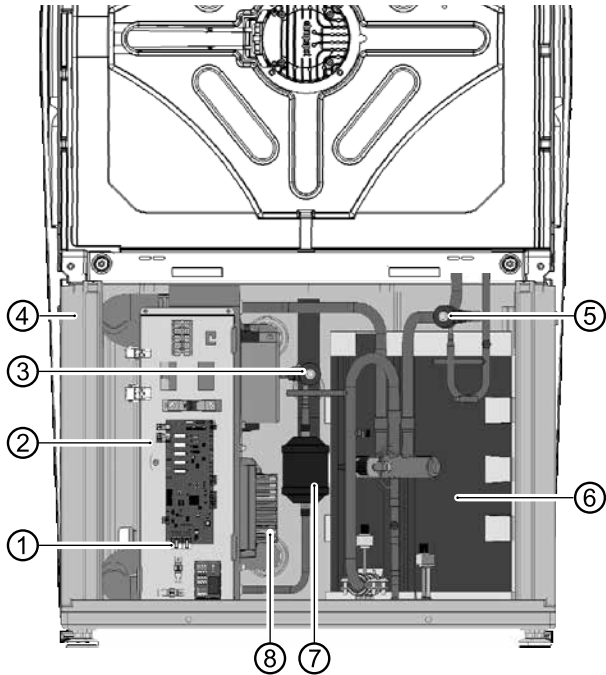

- 1 Plug connection to the fan module
- 2 Electrical switch box
- 3 Expansion valve (cooling, defrost)
- 4 Condenser
- 5 Expansion valve (heating)
- 6 Compressor (in the insulated housing)
- 7 Filter dryer
- 8 Inverter unit

Nameplates

One nameplate is attached to the heat pump module in the rear facade cut-out at the factory.

Two further nameplates are included in the delivery.

- ▶ Stick one nameplate on the outside of the unit on the lower facade of the switch box side.
- ▶ Glue one nameplate into the logbook for heat pumps.

The nameplates contain the following information at the very top:

- Model, item number
- Serial number

The nameplates also contain an overview of the most important technical data.

Control panel

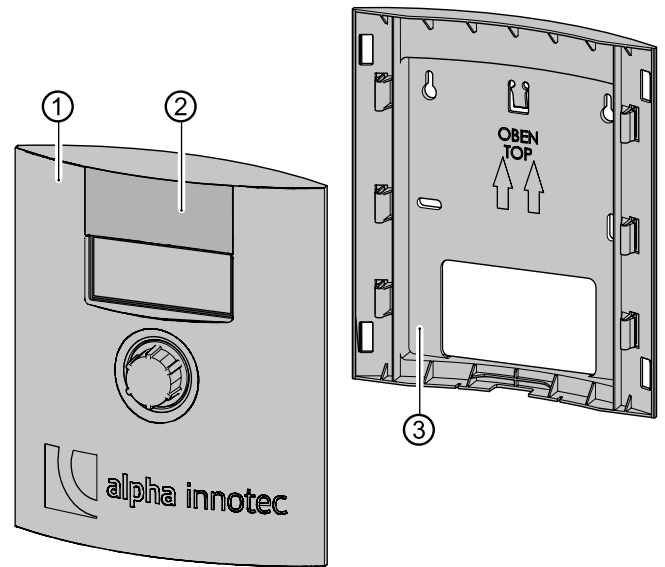

- 1 Control panel
- 2 Push up flap in front of USB connection (for qualified personnel, for software updates and for data logging)
- 3 Wall-mount (will only be detached if the control panel is not being attached to the device but is being mounted on the wall instead)

3.3 Accessories

The following accessories are available for the unit through the manufacturer's local partner:

- Additional masking plate for the front cover panel, if the control panel is mounted on the wall
- Air / magnetic sludge separator
- Domestic hot water tank
- Room thermostat for switching the cooling function
- Dew point monitor for protecting a system with cooling function at low flow temperatures
- Expansion board with various additional functions
- Room control panel for controlling the main functions from the living room



3.4 Function

Liquid refrigerant is evaporated (evaporator), the energy for this process is environmental heat and comes from the outside air. The gaseous refrigerant is compressed (compressor), this causes the pressure to rise and therefore the temperature too. The gaseous refrigerant with high temperature is liquefied (condenser).

Here the high temperature is discharged to the heating water and is used in the heating circuit. The liquid refrigerant with high pressure and high temperature is expanded (expansion valve). The pressure and temperature drop and the process begins again.

Due to the integrated switching valve and the integrated energy efficiency circulation pump the heated heating water can be used for charging the domestic hot water or for heating the building. The temperatures required and use are controlled by the heat pump controller. Reheating, drying out screed or increasing the domestic hot water temperature can be carried out using the integrated electric heating element, which is activated by the heat pump controller as and when necessary.

An integrated overflow valve ensures that the heat pump does not switch to high-pressure fault if all heating circuits are closed. The integrated vibration decouplers for the hydraulics prevent structure-borne sound and vibrations from being transferred into the fixed pipes and therefore into the building.

Cooling

Cooling is integrated in the units. The following options are possible for the cooling function (→ operating manual of the heating and heat pump controller):

- Active cooling
- Control of the cooling function via the heating and heat pump controller
- Changeover between heating and cooling operation

Network connection on the control panel

The control panel can be connected to a computer or network via a network cable. The heating and heat pump controller can then be controlled from the computer or from the network. Furthermore, the manufacturer's internet-based service can also be used.

4 Operation and care



NOTE

The unit is operated via the control panel of the heating and heat pump controller (→ operating manual of the heating and heat pump controller).

4.1 Energy and environmentally aware operation

The generally accepted requirements for energy-aware and environmentally-aware operation of a heating system also apply to use of a heat pump. The most important measures include:

- No unnecessarily high flow temperature
- No unnecessarily high domestic hot water temperature
- Do not open windows with gap /tilt open (continuous ventilation), but instead open wide for a short time (shock ventilation)
- Make sure that the controller settings are correct

4.2 Maintenance

Wipe down the outside of the unit only using a damp cloth or cloth with mild cleaning product (washing-up liquid, neutral cleaning product). Do not use any harsh, abrasive, acid or chlorine-based cleaning products.



5 Delivery, storage, transport and installation

IMPORTANT

Damage to the housing and the unit components due to heavy objects.

- ▶ Do not place any objects on the unit.

5.1 Scope of supply

- ▶ Check delivery immediately after receipt for outwardly visible damage and completeness.
- ▶ Notify supplier of any defects immediately.

The accompanying parts package contains:

Set into the styrofoam component

- 1 supply connection line
28 mm (12 kW) / 22 mm (8 kW)
- 1 return connection line
28 mm (12 kW) / 22 mm (8 kW)
- 3 connection pipes to the heating circuit
- 1 HT-bend DN 40 mm 87°
- Swelling tape for louvre grille and blind cover

Package 1:

- 1 control panel
- 1 outdoor sensor without cable
- 3 Spax screws 5 x 45
- 3 universal wall/floor anchor 6 x 35
- 2 cable ties 3.5 x 200 mm

Package 2:

- 1 safety valve with manometer
1/2" x 3/4", 3 bar

Package 3:

- 1 double-nipple 1/2"
- 1 T-piece 1/2"
- 2 ball valves DN 25 with filling and emptying device, with compression-type fitting
- 1 ball valve DN 25 with compression-type fitting
- 1 fill and drain valve

Package 4:

- Documents (manuals, ERP data and label)
- Installation instructions
- 2 x name plates

Package 5:

- 1 tube lubricant
- 1 protective cover for plug
- 4 EPP screws
- 3 flat seals 5/4"
- 4 flat seals for connection line

In façade package:

- 2 screws M5x16, black for the front wall
- 15 screws for façade mounting
- 1 plastic louvre grille
- 1 heat pump blind cover
- 1 EPP switch box cover
- Blind cover for front wall

5.2 Storage

- ▶ Where possible do not unpack the unit until directly before installation.
- ▶ Store unit protected against:
 - Moisture/damp
 - Frost
 - Dust and dirt



5.3 Unpacking and transport

Notes on safe transport

The unit is heavy (→ “Technical data / Scope of supply”, page 25). There is a risk of injuries or damage to property if the unit falls or overturns.

The hydraulic connections are not designed for mechanical loads.

- ▶ Do not lift or transport the unit by the hydraulic connections.
- ▶ Transport the unit preferably with a pallet truck, alternatively with a handcart or by carrying
- ▶ Do not tilt the heat pump module by more than 45°.



WARNING

Do not transport heat pumps and compact modules on top of one another in unpacked condition - risk of toppling.

- ▶ It is only permitted to use the lashing straps on the heat pump module when carrying by hand.

Transport with a pallet truck

- ▶ Transport the unit to the place of installation packaged and secured on a wooden pallet.

Unpacking

1. Remove plastic films. Ensure that you do not damage the unit.
2. Dispose of the transport and packaging material in an environmentally friendly way and in accordance with local regulations.
3. Remove the film from the plastic element of the front panel in the place of installation.

Lift the housing walls off the pallet and set down

The heat pump comprises the heat pump module and the compact module. These are placed on top of one another on the pallet.

If the unit is not transported by a pallet truck: Do not lift off the pallet until after unpacking and setting down the housing panels.

- The façade front is located in front of the device, along with the accessory package.
- The single-part and two-part side wall are located on the rear side

Optional disconnection of the fan module



NOTE

If required (tight accessways), the fan module can be removed.

1. Disconnect the plug-in connection of the load and bus cable at the top left on the refrigerant circuit switch box.
2. Remove the 4 screws.
3. Remove the fan module and set it down safely.
4. Break off the projecting struts on the supporting crosspieces.

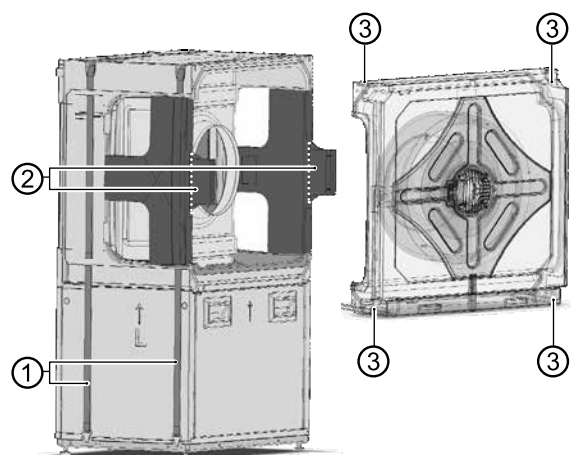

- 1 Lashing straps with grip openings
- 2 Styrofoam strut
- 3 Screws on the fan module

Disconnecting the evaporator module



NOTE

If required, the evaporator module can be disconnected from the refrigerant circuit module. This work must be carried out by the factory customer service department!

- ▶ Please contact the factory customer service department.



Carrying the unit and transporting with handcart

- ✓ Housing walls are set down.

There are two lashing straps around the heat pump module with grip openings at different heights. These can be used for lifting and carrying.

To provide additional stability, two supporting cross-pieces are clamped in the side cut-outs for the air ducts. Do not remove these until transport is complete!

- ▶ Lift the heat pump module off the compact module and set it down.

Carrying the compact module

- ▶ Carry the compact module to the installation site using the 4 lashing straps.

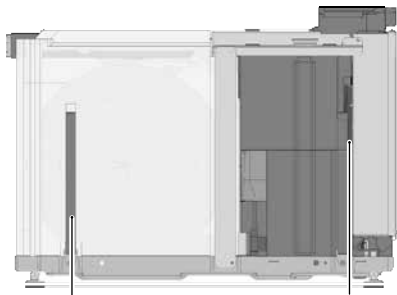

Use two carrying loops on each side

- ▶ The compact module can also be carried on end, with the switch box at the top.

Transporting the compact module with a handcart

1. Load the compact module with the underside of the unit on the handcart.
2. Secure the compact module to the handcart with lashing straps.



3. Transport the compact module to the installation site.

Transporting the heat pump module with a handcart

1. Load the heat pump module only with the narrow side, left or right, on the handcart.

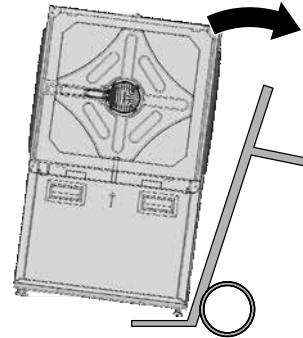

2. Secure the heat pump module to the handcart with lashing straps.



3. Transport the heat pump module to the installation site.



5.4 Installation



CAUTION

In the air outlet area the air temperature is approx. 5° K below the ambient temperature. Under certain climatic conditions an ice layer can therefore form in the air outlet area. Install the heat pump such that the air blower does not discharge into footpath areas.

Installation area and space requirements



NOTE

Note and follow the local regulations and standards regarding the installation area and space requirements. The table shows the regulations to EN 378-1 relevant in Germany.

Refrigerant	Limit value [kg/m ³]
R 134a	0.25
R 404A	0.52
R 407C	0.31
R 410A	0.44
R 448A	0.39
R 454B	0.358

→ “Technical data / Scope of supply”, page 25

$$\text{Minimum room volume} = \frac{\text{Refrigerant capacity [kg]}}{\text{Limit value [kg/m}^3\text{]}}$$



NOTE

If several heat pumps of the same type are installed only one heat pump need to be taken into account. If several heat pumps of different types are installed, only the heat pump with the largest refrigerant volume needs to be taken into account.

- ✓ Minimum volume corresponds to the requirements for the refrigerant used.
- ✓ Installation inside the building only.
- ✓ Installation area is dry and frost-free.
- ✓ Clearance dimensions are met (→ “Installation plans”, page 33)
- ✓ The surface/floor is suitable for installation of the unit:
 - Level and horizontal
 - Load-bearing capacity for the unit's weight



NOTE

The sound emissions of the heat pumps must be taken into account in the respective installation plans for air/water heat pumps. The respective regional regulations must be complied with.

Aligning the unit

1. Align the compact module horizontally and stably in the installation site using the height-adjustable feet and a size 13 spanner. Adjustment range: 20 mm. Then fasten with the size 17 lock nuts.

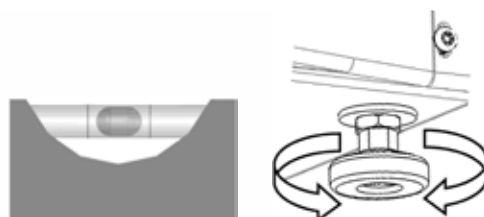

2. Place the heat pump module on the compact module.

If the fan module has been removed this must be reinstalled on the evaporator module. Attach the 4 screws (①) and re-establish the two plug-in connections of the load and bus cables.

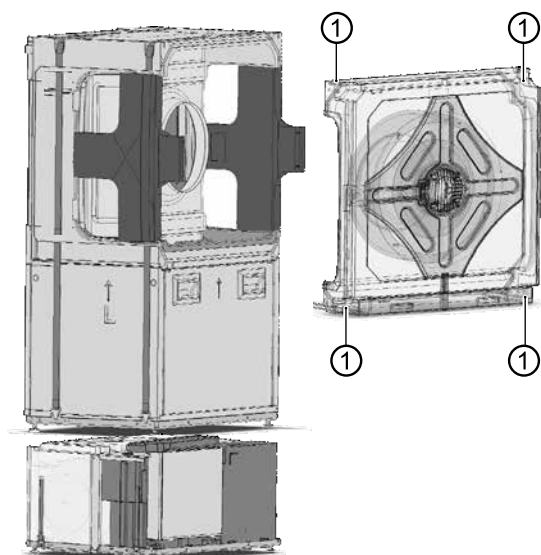

Do not change the adjustable feet of the heat pump module as otherwise the housing walls will no longer fit.



3. Remove the two lashing straps.

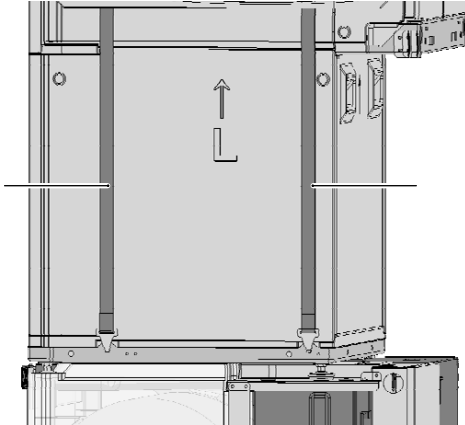

4. Open the strap tensioner and turn the hook on the base plate by 90°.

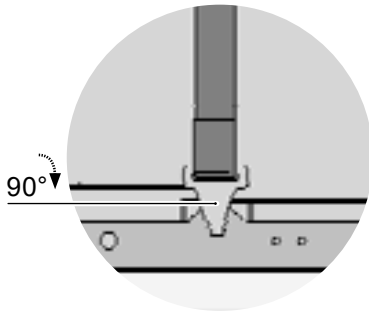

5. Attach the swelling tape to the louvre grille and blind cover by applying it around the edges and then sticking it in place.

→ Heat pump installation instructions

6. Remove the two styrofoam crosspieces.

7. Install the blind cover and the louvre grille.

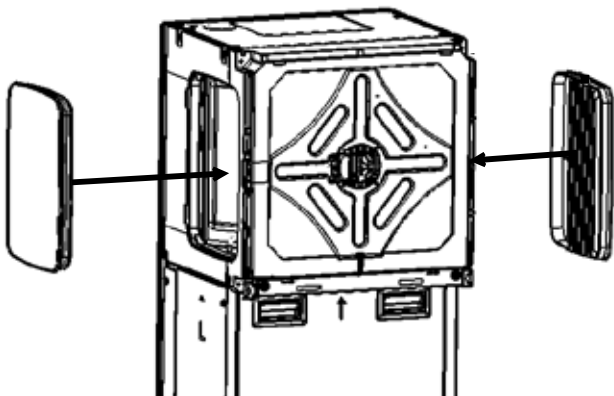

Attach the louvre grille to the air outlet side (right or left)! The blind cover on the opposite side.

8. Attach rear wall and screw firmly into place.

→ Heat pump installation instructions

5.5 Installation of air ducting

Left air outlet



Right air outlet

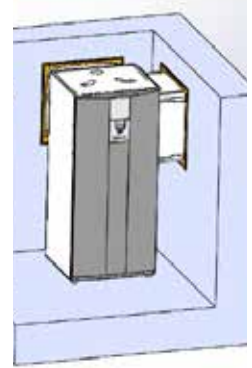

→ Air duct installation instructions

→ Wall duct installation instructions

IMPORTANT

The height difference between the vertical centre of the air duct connections on the unit and the top edge of the air inlet / air outlet on the building must not exceed 2 m.

5.6 Attach side walls, rear wall and cover

→ Heat pump installation instructions

1. Fasten rear wall.
2. Hang side walls from above. Fasten at the front with a screw in the middle. Fasten with 2 screws at the bottom.
3. Fit cover and screw into place.



6 Hydraulic installation



NOTE

The safety valve that is integrated or included in delivery has a tolerance of plus / minus 10% for the set pressure. If local regulations, laws, standards or directives require a smaller tolerance range, the safety valve must be replaced on site with a safety valve that meets the requirements.

IMPORTANT

Avoid open heating systems and / or heating systems that are not oxygen diffusion-tight. If this is not possible, a system separation must be installed.

Depending on the dimensioning of the heat exchanger and the additionally required circulation pump, the system separation worsens the energy efficiency of the system.

IMPORTANT

Dirt and deposits in the (existing) hydraulic system can cause damage to the heat pump.

- ▶ Ensure that a air / magnetic sludge separator is installed in the heating circuit.
- ▶ Ensure that a dirt filter with a mesh size of 0.7 mm is installed as close as possible to the heating water inlet (return).
- ▶ Rinse the hydraulic system thoroughly prior to establishing the hydraulic connection of the heat pump.



NOTE

If an existing system is being replaced, the old vibration decouplers cannot be reused.

IMPORTANT

Damage to the copper pipes due to unacceptable loading!

- ▶ Secure all connections against twisting.
- ✓ Cross-sections and lengths of the pipes for the heating circuit are adequately dimensioned.
- ✓ The free pressing of the circulation pumps in the heating circuit at least results in the throughput required for the device type (→ "Technical data / Scope of supply", page 25).
- ✓ The pipes for the heating are fixed to the wall or ceiling via a fixed point.

6.1 Establish the hydraulic connection between the heat pump module and the compact module

Establish the hydraulic connection between the heat pump module and the compact module with the pre-finished connection kit.

The rear wall must be installed for this!

→ Heat pump installation instructions

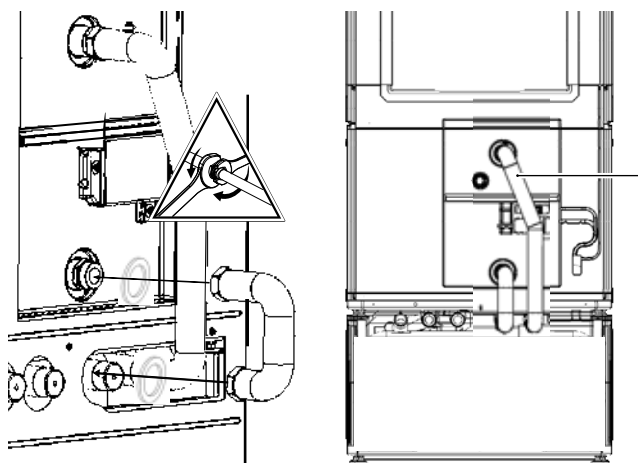

6.2 Connect the unit to the heating circuit

Install the compression fittings and ball valves

IMPORTANT

Leaks or fracture of the union nut due to excessive force!

- ▶ Tighten the union nut only as far as described below.
1. Check pipe ends for scratches, dirt and deformation.
 2. Check proper position of the clamping ring on the fitting.
 3. Push the pipe through the clamping ring up to the limit stop in the fitting.
 4. Tighten the union nut hand-tight and attach waterproof marking.
 5. Tighten union nut with 3/4 rotation.
 6. Check connection for leaks.



If the connection leaks:

1. Undo connection and check pipe for damage.
2. Tighten the union nut hand-tight and retighten with the open-ended spanner with 1/8 to 1/4 turn, as the clamping ring is already in a clamping position.

- Heat pump installation instructions
- Hydraulic integration documentation

The piping can be implemented on the right

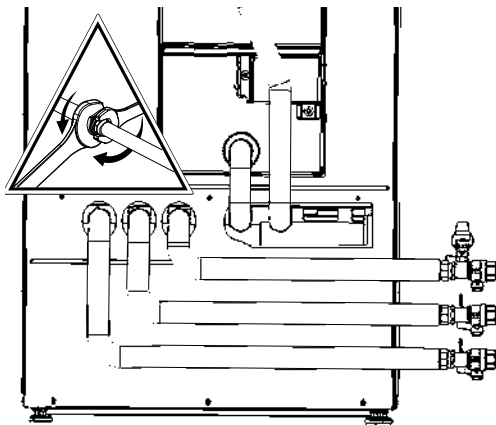

or on the left

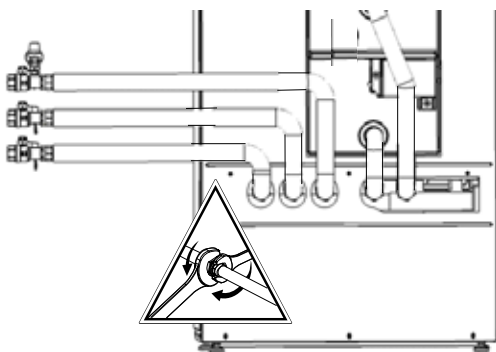

Always install the safety valve in the return line (topmost pipe)!

The copper piping can be shortened but should not be shorter than 250 mm from the centre of the bend!

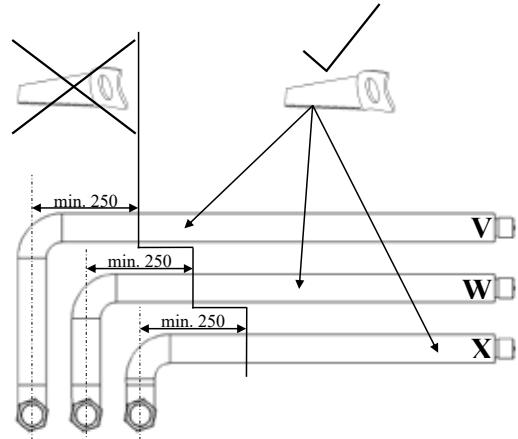

1. Install shut-off devices in the heating circuit.
2. Insert the vent at the highest point of the heating circuit.
3. Ensure that the max. working overpressures (→ "Technical data / Scope of supply", page 25) are not exceeded.

6.3 Condensate connection

The outlet for the hot water safety valve and the condensate from the air must be drained off in accordance with the respective applicable standards and regulations. Discharging the condensate and the outlet for the safety valve into the sewers is permitted only via a funnel waste trap, which must be accessible at all times.

1. Fit an HT-bend onto the condensate outlet.
 2. Route piping into the funnel waste trap.
- Heat pump installation instructions

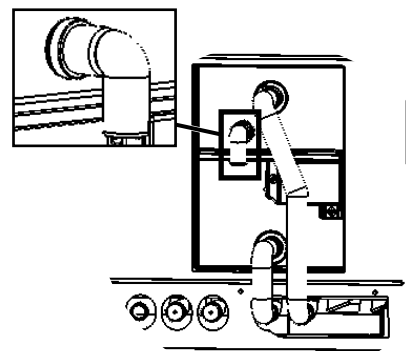



7 Electrical installation

7.1 Establish the electrical connection between the heat pump module and the compact module

1. Route the two plug-in connections of the load and bus cable from the compact module to the plug-in points on the heat pump module.
2. Couple the connectors together.

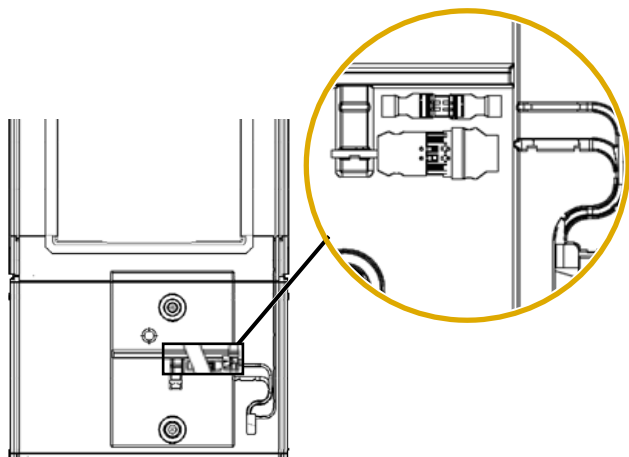

3. Fit cover for plug-in connections.

7.2 Connect the electrical cables

IMPORTANT

Irreparable damage to the compressor due to wrong rotating field (only applies to units with 400V connection).

- Ensure a clockwise rotating field for the compressor's load supply.

Basic information on the electrical connection

- The specifications of the local energy supply company may apply to electrical connections
- Fit the power supply for the heat pump with an all-pole miniature circuit-breaker with at least 3 mm contact spacing (per IEC 60947-2)
- Note the level of the tripping current (→ "Technical data / Scope of supply", page 25)
- Comply with the electromagnetic compatibility regulations (EMC regulations)
- Lay unshielded power supply cables and shielded cables (bus cable) sufficiently far apart (> 100 mm).

- Maximum line length: 30 m.
The bus cable must be a shielded cable of at least 4 x 0.5 mm²

Pulling in the cables and conductors and making the connections

The electrical connection is established via the compact module switch box.



NOTE

Cables must have adequate excess length.

1. Strip the sheathing of all cables to the external loads before laying in the cable gland of the control box.
2. Route the cable through the cable gland and into the switch box.

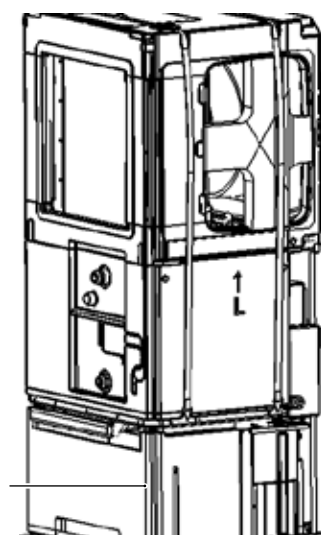

Cable gland on the rear of the unit

3. Open electrical switch box.
4. Remove the cover panel.
The cover panel (②) can be inserted into the bottom edge as a strut such that the open switch box (①) can be more easily closed at a 45° angle.

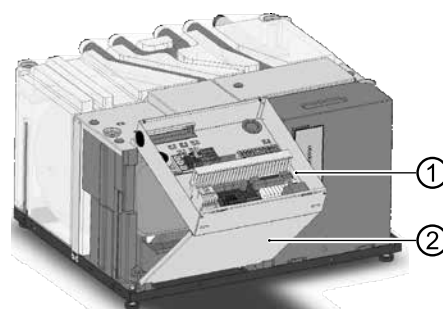



5. Feed the control/sensor cables and unit supply cable into the housing from the rear.
6. Connect cables to the respective terminals → "Terminal diagrams", from page 46



NOTE

In units with integrated electric heating element, the electric heating element is connected at 9kW (6 kW) in the factory. At contactor Q it is possible to select 6 kW (4kW) = 2 phase operation. Disconnect Q5/6 for this. Or 3kW (2kW) = 1 phase operation. Disconnect Q5/6 and Q5/4 for this.

The values in brackets are for the 6 kW heating element. Disconnected cables must be furnished with screw terminals. Only the phases cited above may be disconnected (safety temperature limiter).

8 Installing the control panel



NOTE

The control panel can be inserted in a recess in the front panel of the unit or can be installed on the wall.

→ Heat pump installation instructions

8.1 Mount the control panel on the wall and connect

1. Release the rear bracket from the control panel.
2. If visually unattractive: Cut off the snap noses on the rear of the control panel (are only needed to insert in the front panel).
3. Mark 2 drill holes (→ "Wall-mounting bracket", page 32).
4. If cables are fed in from underneath: Break out the web at the bottom in the middle of the wall bracket. Use side cutters if necessary.
5. Fix the wall-mounted bracket (②) with 2 wall plugs (①) and 2 screws (③).

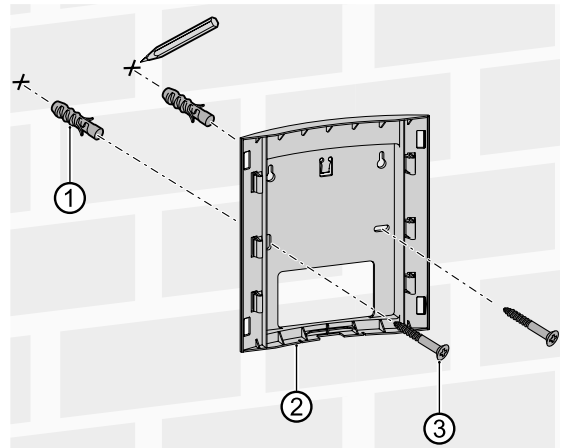

6. Feed in the cables from the wall (e.g. in-wall box) or from below.
7. Route the Modbus cable through the cable gland between the compact module and the heat pump module and into the control panel on the underside.
8. Push the control panel onto the wall-mounted bracket.
9. Put on the masking plate if applicable (accessories).



8.2 Connections of the control panel

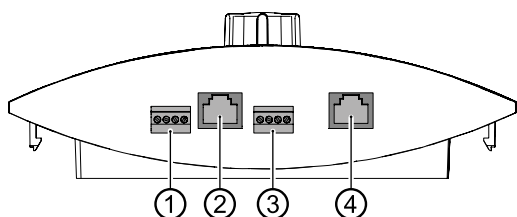

- 1 Room control panel RBE RS 485 (accessory) connection
- 2 Network cable connection
- 3 LIN-bus cable connection to the controller board
- 4 Modbus cable to Modbus distributor connection

8.3 Operate the controller via a PC / network

1. During installation lay a shielded network cable (category 6) through the unit.
2. Plug the RJ-45 connector of the network cable into the socket of the control panel (①).

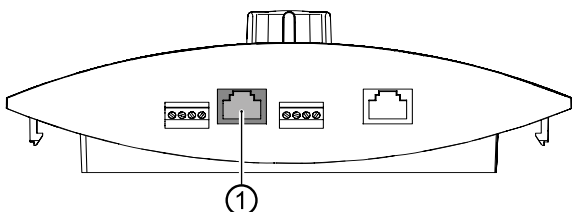

NOTE

The network cable can be retrofitted at any time.

9 Flushing, filling and venting

9.1 Heating water quality



NOTE

For detailed information refer, among other things, to the VDI Guidelines 2035 “Vermeidung von Schäden in Warmwasserheizanlagen” (preventing damage in hot water heating systems).

1. Ensure that the pH-value of the heating water is between 8.2 – 10, for aluminium materials between 8.2 – 9.
Ideally, the pH value should already be in the required range after filling. After 6 weeks at the latest, it must have adjusted to the required range.
2. Ensure that the electrical conductivity is $< 100 \mu\text{S/cm}$.



NOTE

If the required water quality is not achieved, consult a company specialising in the treatment of heating water.

3. Fill the system with deionised heating water (VE water) or with water corresponding to the VDI 2035 norm only (low-salt operation of the system).
Advantages of low-salt operation:
 - Low corrosion-promoting properties
 - No formation of mineral scale
 - Ideal for closed heating circuits
4. Keep a system log for hot water heating systems in which relevant planning data and the water quality are entered (VDI 2035).

9.2 Flush and fill the heating and domestic hot water charging circuit

- ✓ Outlet pipe of the safety valve is connected.
- Ensure that the set pressure of the safety valve is not exceeded.

IMPORTANT

Flush the heating circuit only in its flow direction.



i

NOTE

The venting program on the controller can also be used to support the flushing and venting process. It is possible to control individual circulation pumps and even the switching valve through the venting program. As a result it is not necessary to remove the valve motor.

1. Pull the U-clip (②) off the bottom of the valve motor (①).

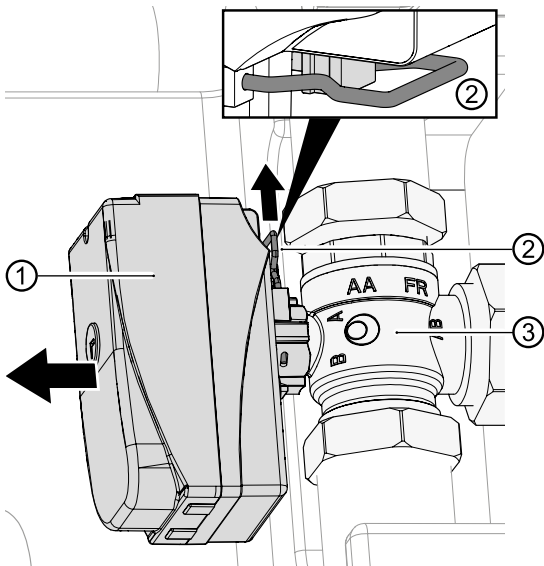

2. Pull the valve motor (①) carefully off the 3-way switching valve (③).
3. Turn the spindle of the 3-way switching valve so that the rounded side of the spindle points in the direction of marking A of the connections of the 3-way switching valve.

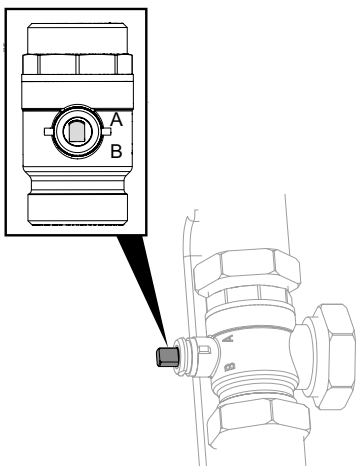

4. Flush the domestic hot water charging circuit for approx. 1 minute.

5. Turn the spindle so that the rounded side of the spindle points in the direction of marking B of the connections of the 3-way switching valve.
6. Flush heating circuit thoroughly, until no more air is discharged.
7. Vent system at the respective highest point.
8. Vent heat pump.
9. Position the valve motor (①) on the 3-way switching valve (③).
10. Insert the U-clip (②) into the bottom of the valve motor.

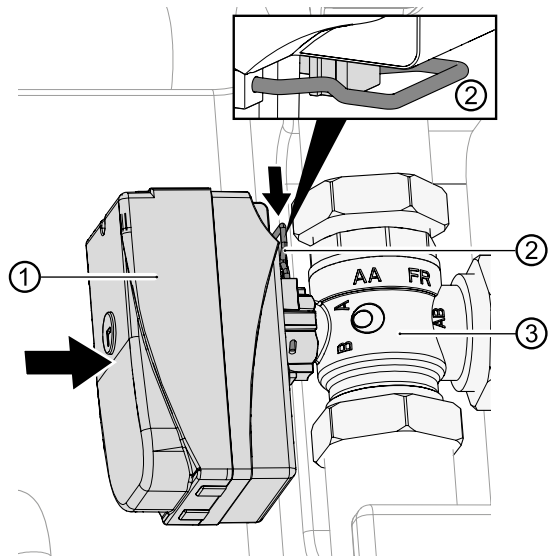

11. Ensure that the U-clip has latched into position correctly:
 - ✓ Valve motor sits securely on the 3-way switching valve
 - ✓ Both prongs of the U-clip sit on the lug
 - ✓ The tips of the U-clip are not visible more than approx. 2 mm

10 Insulate hydraulic connections

Insulate hydraulic lines in accordance with local regulations.

1. Open shut-off devices.
2. Perform a pressure test and check for leaks.
3. Insulate external piping on site.
4. Insulate all connections, fittings and pipes.



11 Set the overflow valve



NOTE

- The activities in this section are only necessary for integration of storage tank in series
 - Complete the worksteps quickly, otherwise the maximum return temperature can be exceeded and the heat pump switches to high-pressure fault
 - Turn the adjusting knob at the overflow valve to the right to increase the temperature difference (the spreading), turn it to the left to reduce it
- ✓ System is running in heating mode (ideally in cold condition).

There is a facility directly in the IBN assistant to adjust the overflow valve to suit the hydraulic system if the storage tank is integrated in series.

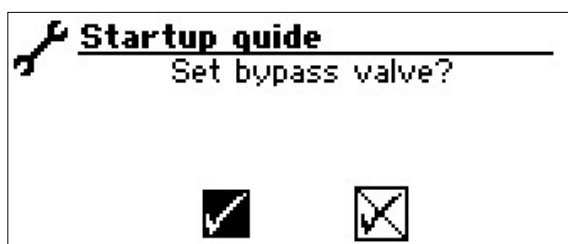

Confirm the IBN assistant or:

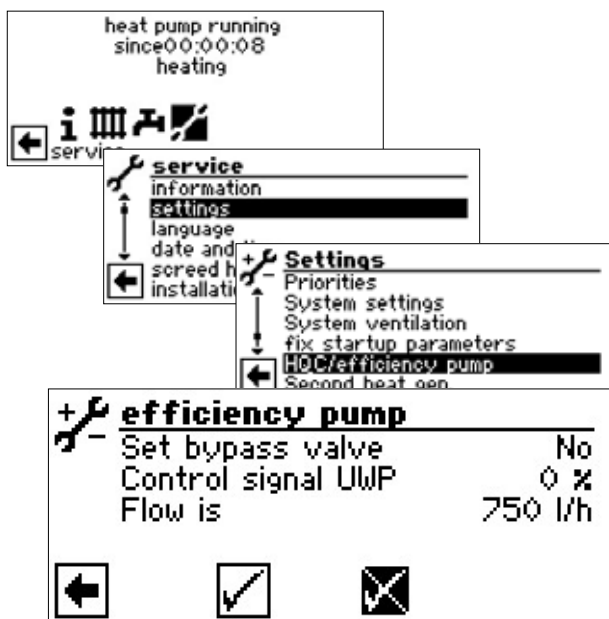

The “Set bypass valve” menu item is set by default to “No”. The overflow valve adjustment function is deactivated.

- The UWP control signal is the indication of the currently required pump capacity in %
 - If the flow rate is the current flow rate (measuring accuracy +/- 200 l/h)
1. Fully open the overflow valve, close the heating circuit.
 2. Set the menu point “Set bypass valve” from “No” to “Yes” and so the circulation pump is controlled with 100% – the pump starts up.
 3. If the UWP control signal reaches 100%, close overflow valve far enough that the max. flow rate (→ “Technical data / Scope of supply”, page 25) can be assured.

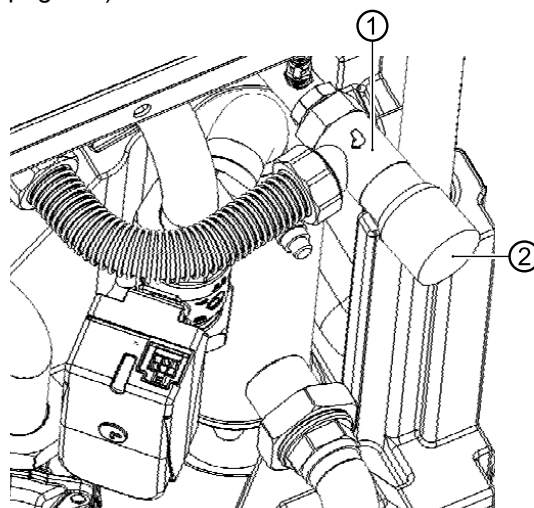

- 1 Overflow valve
- 2 Adjusting knob

4. If you leave the “Set bypass valve” menu or after one hour at the latest, the circulation pump switches back to its standard regulation.
5. Open valves to heating circuit.



12 Commissioning



CAUTION

The unit may only be started up if the air ducts, weather and/or rain louvres have been installed and the facing panels are closed.

- ✓ Relevant planning & design data of the system is documented in full
 - ✓ The competent energy supplier has been notified of operation of the heat pump system
 - ✓ System is air-free
 - ✓ Installation check using the rough checklist has been completed successfully
 - ✓ Clockwise rotating load infeed field is present at the compressor (only applies to units with 400V connection)
 - ✓ The system is installed and mounted in accordance with this operating manual
 - ✓ The electrical installation has been carried out properly in accordance with this operating manual and local regulations
 - ✓ The power supply for the heat pump is equipped with an all-pole circuit-breaker with at least 3 mm contact spacing (IEC 60947-2)
 - ✓ The level of the tripping current is compliant
 - ✓ Heating circuit is flushed and vented
 - ✓ All shut-off devices of the heating circuit are open
 - ✓ The pipe systems and components of the system are leak-tight
1. Carefully fill in and sign the notice of completion for the heat pump systems.
 2. In Germany: Send notice of completion for heat pump systems and general checklist to the manufacturer's factory customer service department. In other countries: Send notice of completion for heat pump systems and general checklist to the manufacturer's local partner.
 3. Arrange for the heat pump system to be commissioned by the manufacturer's authorised after sales service for a fee.
- "13.2 Maintenance after commissioning", page 22

13 Maintenance



NOTE

We recommend that you sign a maintenance agreement with an accredited heating company.

13.1 Basic principles

The cooling circuit of the heat pump requires no regular maintenance.

Local regulations among other things, require leakage controls beforehand and/or for a log book to be kept for certain heat pumps.

- ▶ Ensure compliance with local regulations with regard to the specific heat pump system.

13.2 Maintenance after commissioning

Immediately after commissioning, check all installed dirt traps for dirt and clean them if necessary.

- ▶ Switch off the system while the check and cleaning is being carried out.

Next checking and cleaning at the latest 2 weeks after commissioning.

13.3 Maintenance as required

- ▶ Checking and cleaning the components of the heating circuit, e.g. valves, expansion vessels, circulation pumps, filters, dirt traps.
- ▶ The air intake and exhaust openings must always be free of obstructions and kept clear. Therefore, check for unimpeded air infeed accordingly. Constrictions or even blockages which, for example occur
 - when applying house insulation with polystyrene balls
 - through packaging material (foils, films, cartons etc.)
 - through foliage, snow, icing or similar weather-related deposits
 - through vegetation (bushes, tall grass etc.)
 - through air shaft covers (fly protection screens etc.)and which must be prevented and/or removed immediately.



- ▶ Check at regular intervals that the condensate can drain out of the device freely, without obstruction. To this end, check the condensate pan in the device regularly for dirt/clogging and clean as necessary. Also check the evaporator from all sides and clean if necessary.

Check the evaporator and the condensate pan and clean them, if required

1. Remove the front panel, the side panels and the cover, thus gaining access to the cover of the cleaning opening (①).

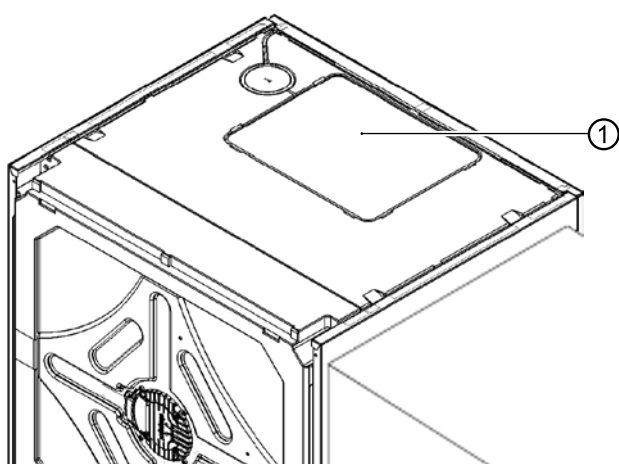

2. After the cover is removed (①), the entire condensate pan area before (②) and after (③) the evaporator is visible and can be cleaned if necessary.

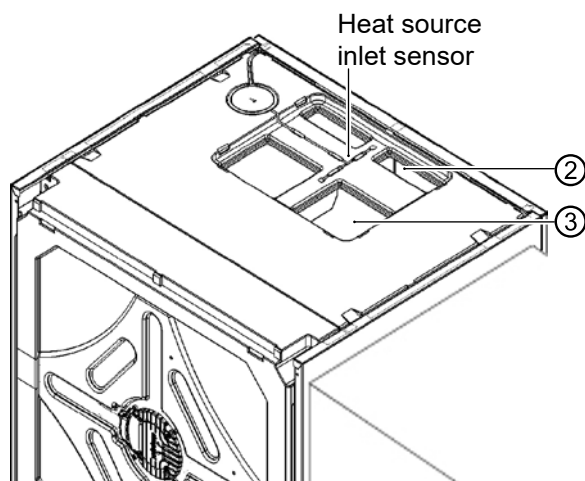

As an alternative, the lateral air ducts, the side walls, the louvre grilles and blind covers can be removed (if necessary also the fan module), to obtain better access.

→ "Optional disconnection of the fan module", page 11

13.4 Clean and flush condenser

- ▶ Clean and flush the condenser in accordance with the manufacturer's instructions.
- ▶ After flushing the condenser with chemical cleaning product: Neutralise any residues and flush the condenser thoroughly with water.

13.5 Yearly maintenance

- ▶ Determine the quality of the heating water by analysis. In the event of deviations from the specifications, take suitable measures without delay
- ▶ Check all installed dirt traps for dirt and clean them if necessary.
- ▶ Test the function of the safety valve for the heating circuit.



14 Faults

1. Read out the cause of the fault via the diagnostics program of the heating and heat pump controller.
2. Contact the local partner of the manufacturer or the factory's customer service. Have the fault message and unit number to hand.

→ "Nameplates", page 8)

Unlock the safety temperature limiter

A safety temperature limiter (②) is installed in the electric heating element (③). If the heat pump fails or there is air in the system:

- ▶ Check whether the reset knob (①) in the centre of the safety temperature limiter (②) has jumped out (located underneath the cover).

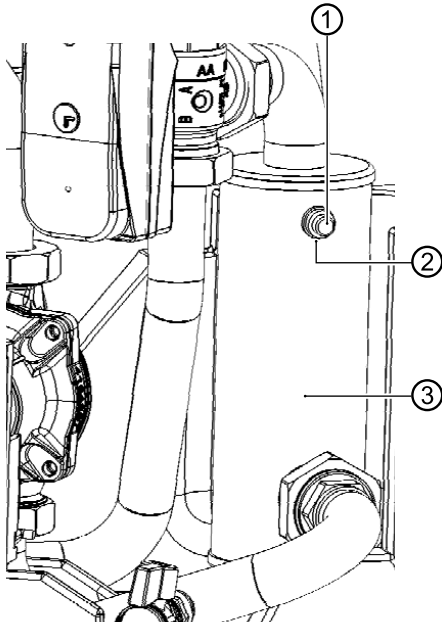

- ▶ Press the reset button back in again.
- ▶ If the safety temperature limiter trips again, contact the local partner of the manufacturer or the factory's customer service.

15 Dismantling and Disposal

15.1 Dismantling

- ▶ Collect all substances safely.
- ▶ Separate components according to their materials.

15.2 Disposal and recycling

- ▶ Dispose of environmentally hazardous substances (e.g. refrigerant, compressor oil) according to the local regulations.
- ▶ Ensure the correct recycling or disposal of device components and packaging materials in accordance with the local regulations.

15.2.1 Buffer battery

1. Use a screwdriver to push out the buffer battery on the processor board of the control panel

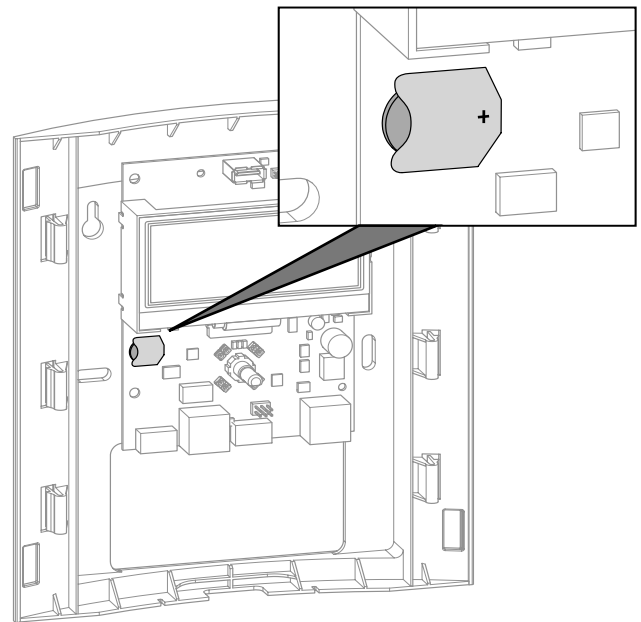

2. Dispose of the buffer battery (type: CR2032, lithium) in accordance with local regulations.



LWCV

Technical data / Scope of supply

Performance data		Values in brackets: (1 Compressor)		LWCV 82R1/3	LWCV 122R3
Heating capacity COP	for A10/W35 acc. to DIN EN 14511-x: 2013	Partial load operation	kW COP	3.18 5.25	5.50 5.10
	for A7/W35 acc. to DIN EN 14511-x: 2013	Partial load operation	kW COP	2.81 5.03	5.29 4.71
	for A7/W55 acc. to DIN EN 14511-x: 2013	Partial load operation	kW COP	3.28 2.85	9.36 2.65
	for A2/W35 acc. to DIN EN 14511-x: 2013	Partial load operation	kW COP	3.82 4.19	5.00 4.01
	for A-7/W35 acc. to DIN EN 14511-x: 2013	Full load operation	kW COP	6.40 3.17	8.50 2.63
	for A-7/W55 acc. to DIN EN 14511-x: 2013	Full load operation	kW COP	4.93 2.20	8.46 2.05
Heating capacity	for A10/W35	min. max.	kW kW	2.90 7.00	5.40 11.0
	for A7/W35	min. max.	kW kW	2.80 6.60	5.40 11.0
	for A7/W55	min. max.	kW kW	2.50 6.40	4.50 11.0
	for A2/W35	min. max.	kW kW	2.60 6.40	4.60 10.3
	for A-7/W35	min. max.	kW kW	2.30 6.50	3.60 8.50
	for A-7/W55	min. max.	kW kW	1.80 4.95	2.80 8.50
Cooling capacity EER	for A35/W18	Partial load operation	kW EER	3.20 2.10	7.20 3.70
	for A35/W7	Partial load operation	kW EER	— —	— —
Cooling capacity	for A35/W18	min. max.	kW kW	2.00 4.60	4.70 8.50
	for A35/W7	min. max.	kW kW	— —	— —
Heating capacity domestic hot water preparation			kW	5	8
Operating limits					
Heating circuit return min. Heating circuit flow max. Heating		within heat source min./max.	°C	20 45	20 45
Heat source, heating		min. max.	°C	-22 35	-22 35
Additional operating points			...	A-5 / W60	A-5 / W60
Sound					
Sound power level inside		min. Night max.	dB(A)	43 53 54	43 53 54
Sound power level outside 1)		min. Night max.	dB(A)	34 38 44	30 43 49
Sound power level acc. to DIN EN 12102-1:2017		inside outside	dB(A)	48 44	47 49
Tonality Low-frequency			dB(A) • yes – no	— —	— —
Heat source					
Air flow rate at maximum external pressing Maximum external pressure			m³/h Pa	2500 25	2900 25
Heating circuit					
Flow rate (pipe dimensioning) Min. volume buffer tank in series Min. volume separation buffer tank			l/h	1200 60 100	1900 100 200
Free pressing Pressure loss Flow rate			bar bar l/h	0.75 — 1200	0.57 — 1900
Max. allowable operating pressure			bar	3	3
Circulation pump control range		min. max.	l/h	600 1200	600 - 1900
General unit data					
Total weight			kg	208,00	227,00
Weight of heat pump module Compact module Fan module			kg kg kg	88 57 16	104 60 16
Refrigerant type Refrigerant capacity			... kg	R410A 3.00	R410A 3.60
Electrics					
Voltage code all-pole fuse protection for heat pump *)**			... A	1-N/PE/230V/50Hz B16	3-N/PE/400V/50Hz B16
Voltage code Control voltage fuse protection **)			... A	1-N/PE/230V/50Hz B10	1-N/PE/230V/50Hz B10
Voltage code Electric heating element fuse protection **)			1 phase	—	—
Voltage code Electric heating element fuse protection **)			3 phases	... A	3-N/PE/400V/50Hz B10
HP*): effect. Power consumption A7/W35 (partial load operation) DIN EN 14511-x: 2013 Electric consumption I cosφ			kW /	0.559 1.09 0.83	1.12 2.40 0.83
HP*): effective power consumption A7/W35 acc. to DIN EN 14511-x: 2013: min. max.			kW kW	0.5 —	1.12 —
HP*): Max. machine current Max. power consumption within the operating limits			A kW	16 3.5	13 6.0
Starting current: direct with soft starter			A A	< 5 —	< 5 —
Degree of protection			IP	20	20
Zmax			Ω	—	—
Residual current circuit breaker if required			type	B	B
Electric heating element output			3 2 1 phase	kW kW kW	6 4 2
Circulation pump power consumption, heating circuit			min. max.	W	4 – 75
Other unit information					
Safety valve heating circuit Response pressure			included in scope of supply: • yes – no bar	• 3	• 3
Buffer tank Volume			included in scope of supply: • yes – no l	• 82	• 82
Heating circuit expansion vessel Volume Prepressure			incl. in scope of supply: • yes – no l bar	• 12 1.5	• 13 1.0
Overflow valve Changeover valve heating - domestic hot water			integrated: • yes – no	• •	• •
Heating circuit vibration decoupling			incl. in scope of supply or integrated: • yes – no	•	•
Controller I Heat quantity recording I Extension board			incl. in scope of supply or integrated: • yes – no	• • —	• • —
*) compressor only, **) note local regulations 1) Indoor and outdoor installation.					
For indoor installation: Intake 1.5m air duct, Blow-out 1.5m air duct + air duct bend (original accessories)				831579f	813580e
The performance data and the operating limits apply to clean heat exchangers I Index: I					



Performance curves / operating limits / heating

LWCV 82R1/3

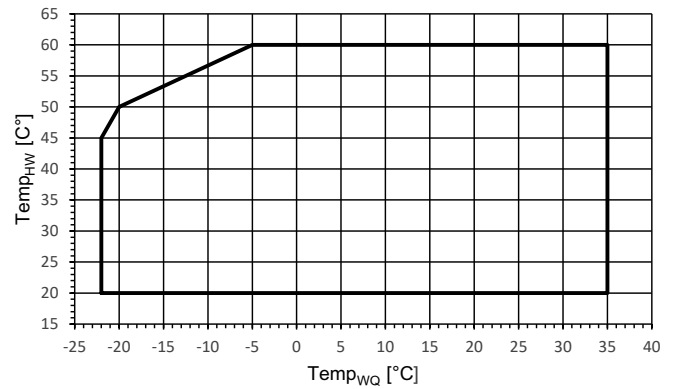
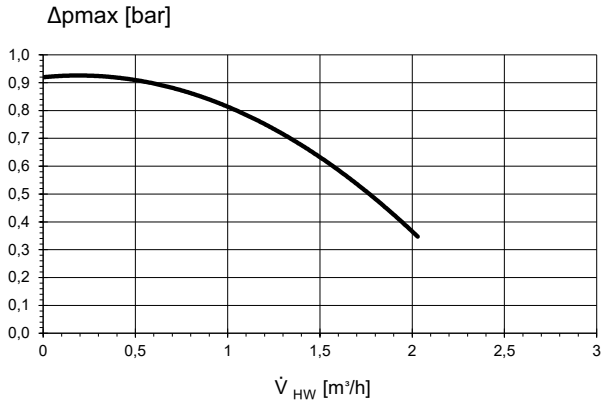
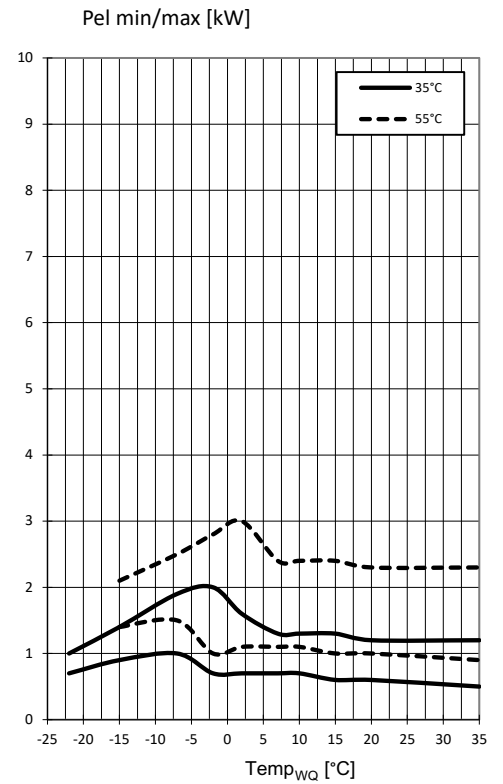
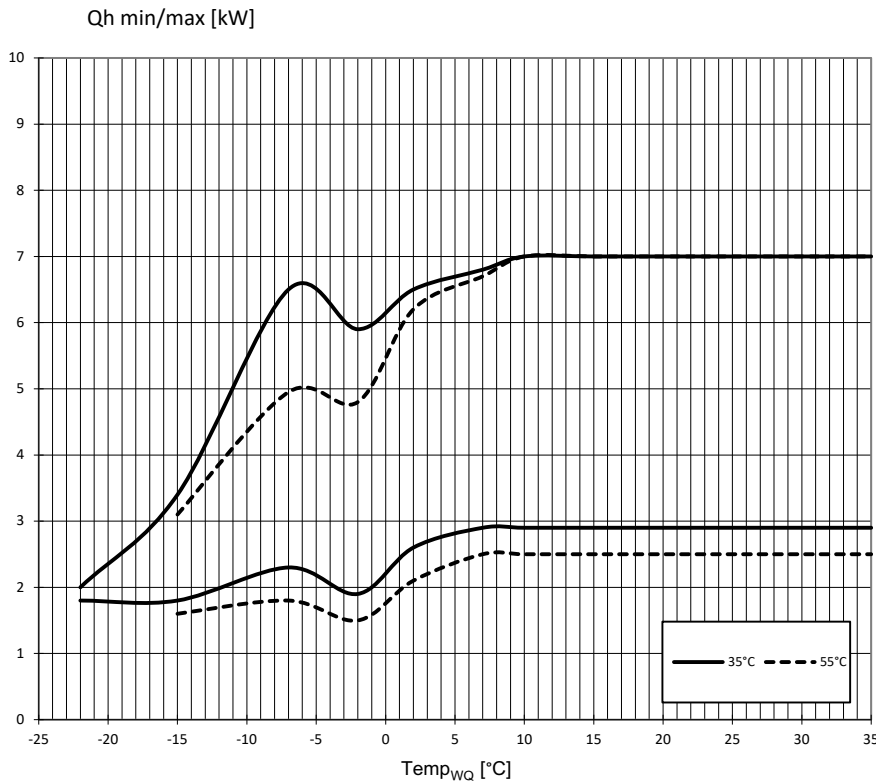

823292 d

Keys: 823292d

\dot{V}_{HW}	Volume flow rate heating water
Temp _{WQ}	Heat source temperature
Δpmax	max. free pressing
Qh min/max	min./max. heating power
Pel min/max	min./max. power consumption



LWCV 82R1/3

Performance curves / cooling

Q0 min/max [kW]

Pel min/max [kW]

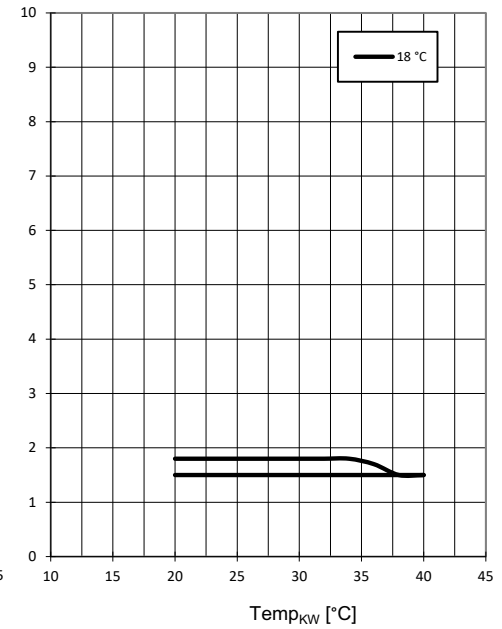
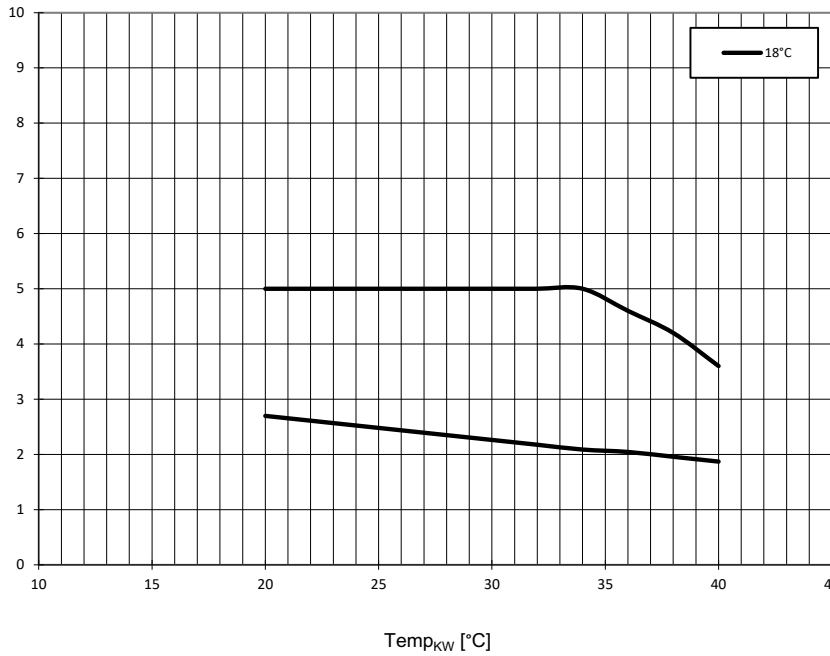

Δpmax [bar]

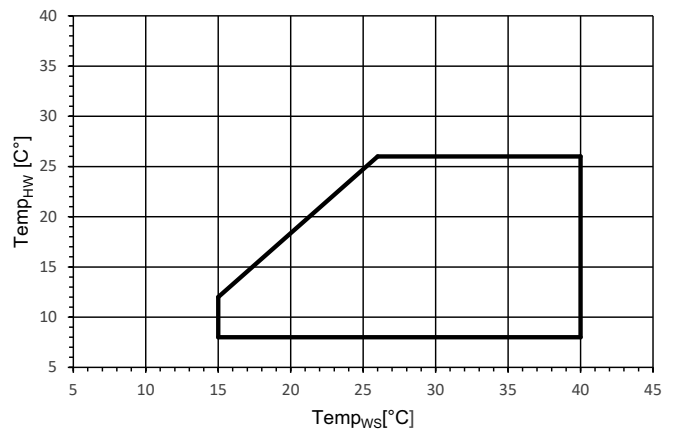
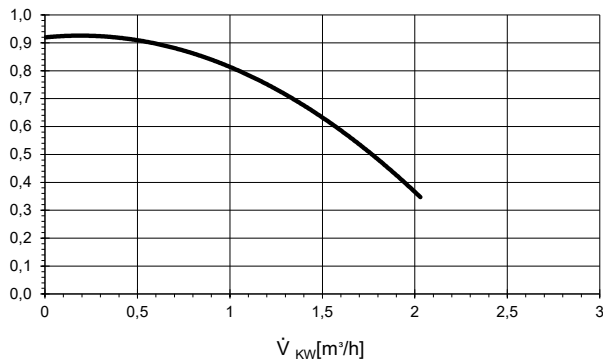

823292 d

Keys: 823292d

\dot{V}_{KW}	Volume flow rate cooling water
Temp _{WS}	Heat sink temperature
Temp _{KW}	Cooling water temperature
Δpmax	max. free pressing
Q0 min/max	min./max. cooling capacity
Pel min/max	min./max. power consumption

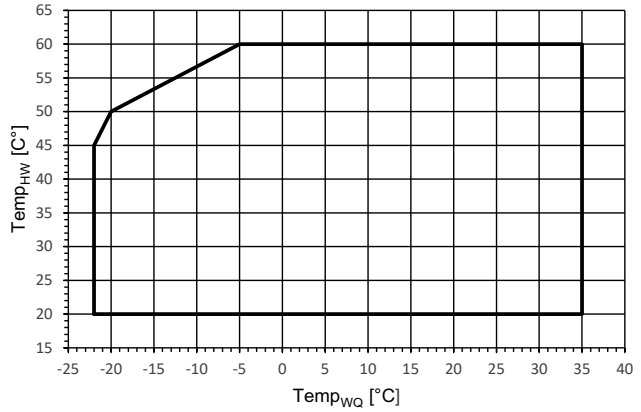
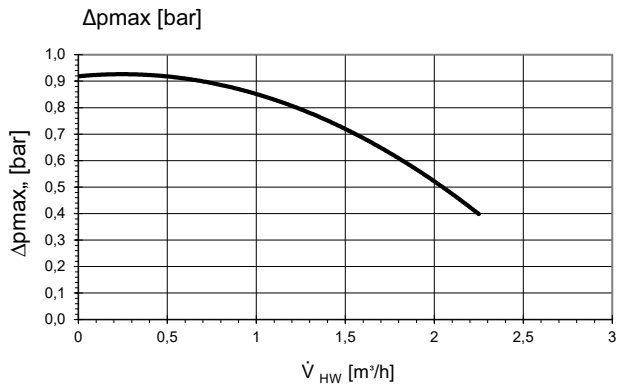
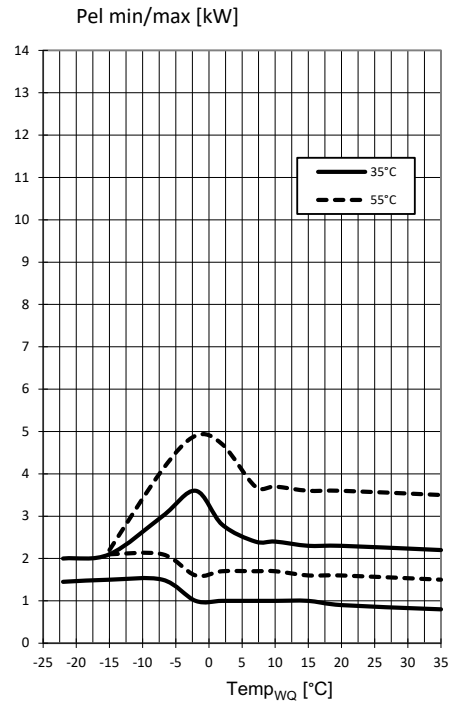
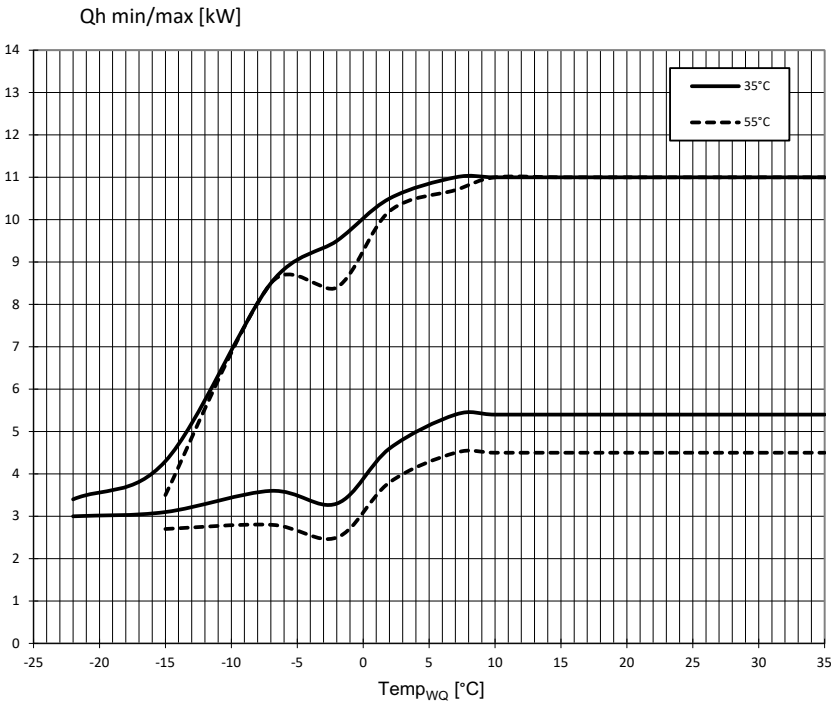

823293 d

Keys: 823293d

\dot{V}_{HW}	Volume flow rate heating water
$Temp_{WQ}$	Heat source temperature
Δp_{max}	max. free pressing
Qh min/max	min./max. heating power
Pel min/max	min./max. power consumption



LWCV 122R3

Performance curves / cooling

Q0 min/max [kW]

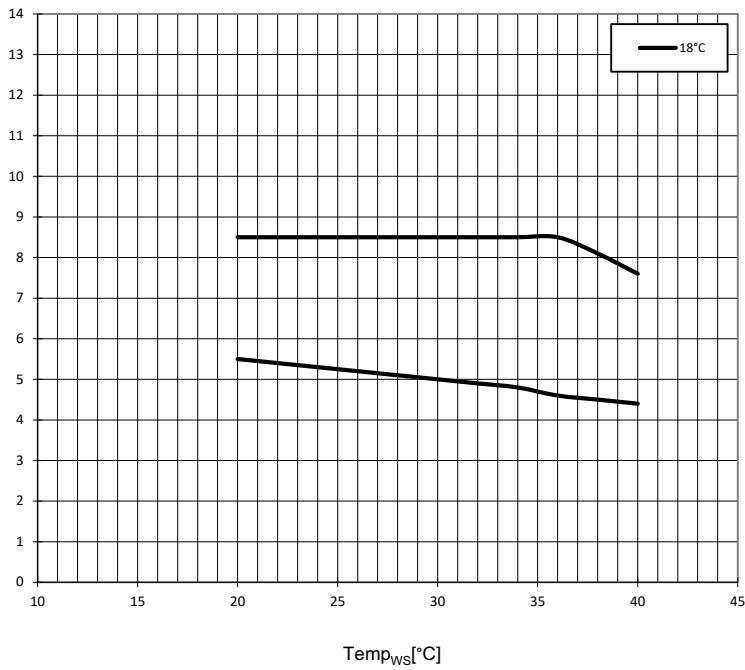

Pel min/max [kW]

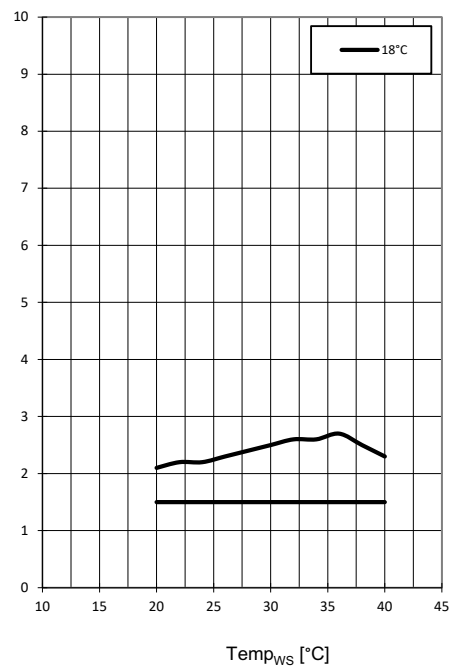

Δpmax [bar]

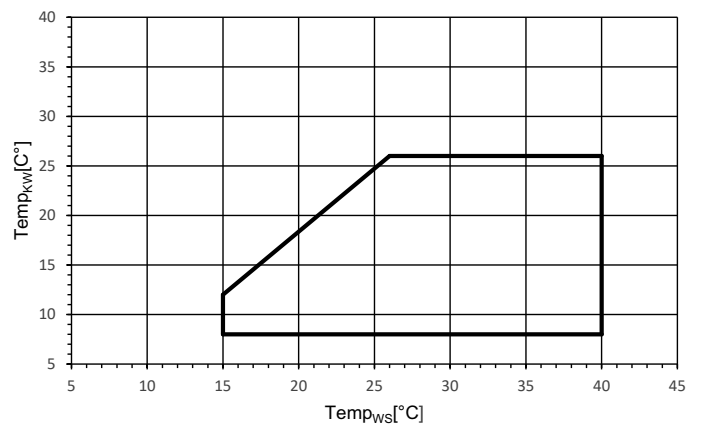
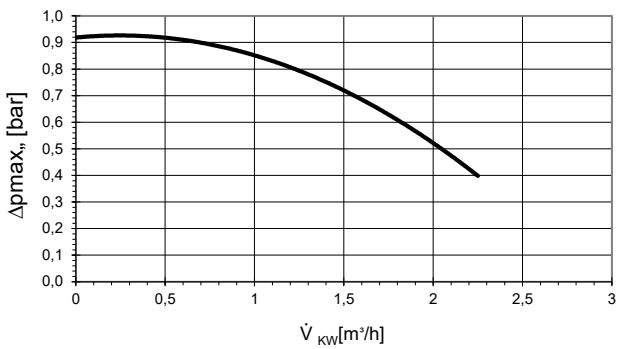

823293 d

Keys: 823293d

\dot{V}_{KW}	Volume flow rate cooling water
Temp _{ws}	Heat sink temperature
Δpmax	max. free pressing
Q0 min/max	min./max. cooling capacity
Pel min/max	min./max. power consumption



Dimensional drawing 1

LWCV

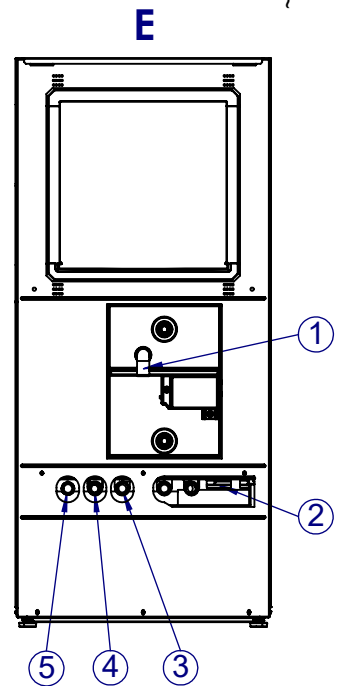
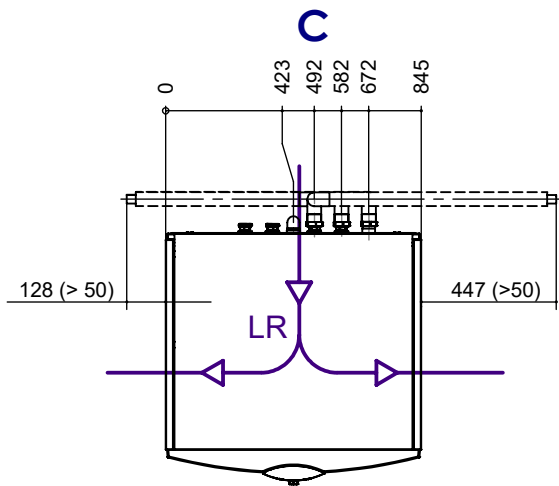
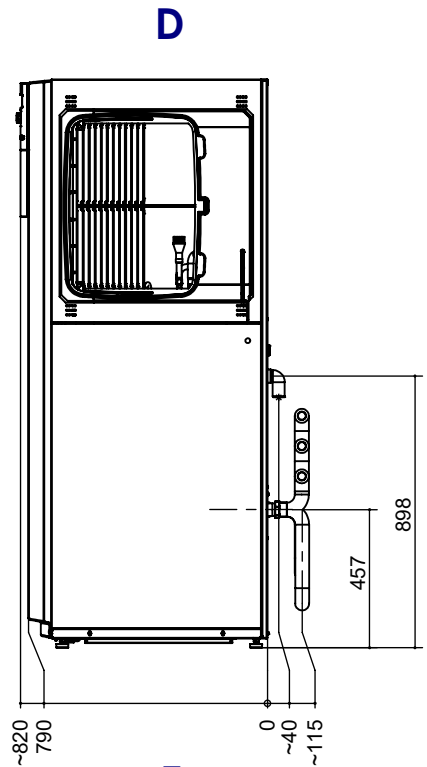
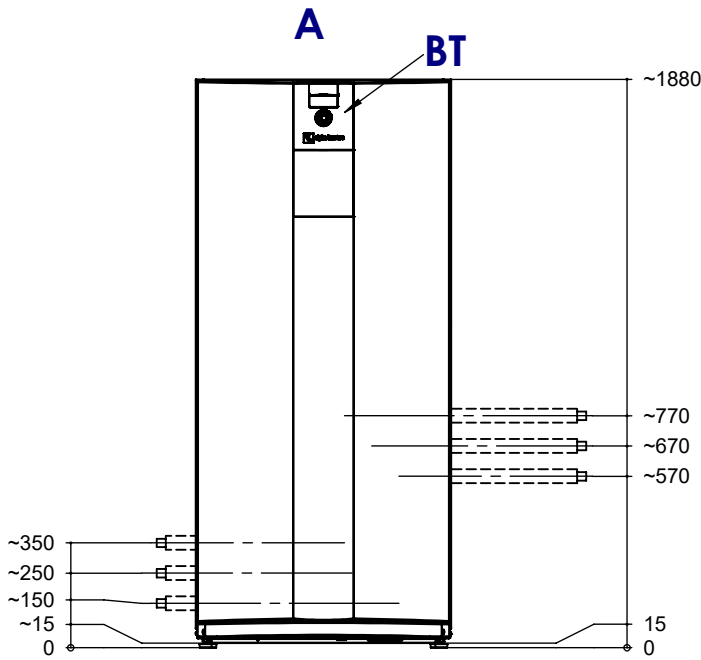

Keys: UK819474a

All dimensions in mm.

Pos.	Name	Dim.	incl. scope of supply
1	Condensate drain HT pipe	DN 40	
2	Cable bushing		
3	Hot water / domestic hot water Inlet (return) + safety valve Rp 3/4" + heating circuit manometer	G 5/4" External thread	Pipe dimensions outside Ø28
4	Domestic hot water outlet (supply flow)	G 5/4" External thread	Ball valves Internal thread Rp 1"
5	Hot water outlet (supply flow)	G 5/4" External thread	
A	Front view		
C	Top view		
D	Side view from right		
E	Rear view without piping		
LR	Air direction (left or right, can be selected on site)		
BT	Control panel		



LWCV

Dimensional drawing 2

A1

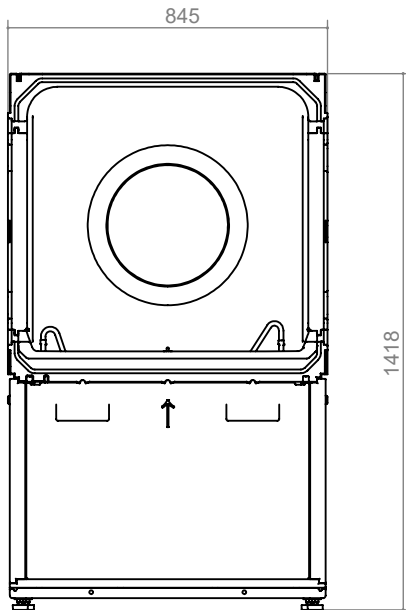

B1

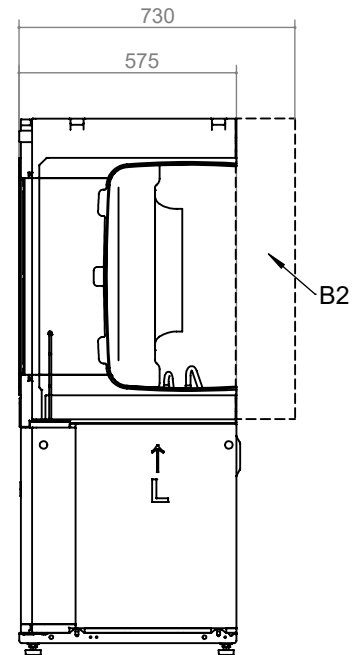

A2

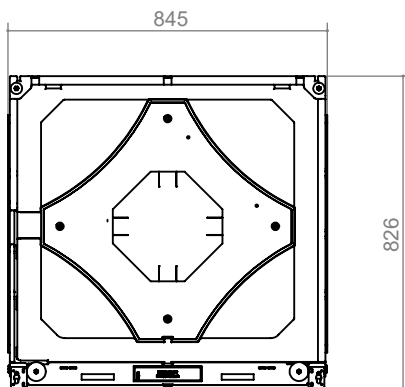

B2

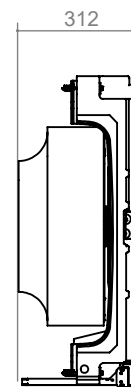

A3

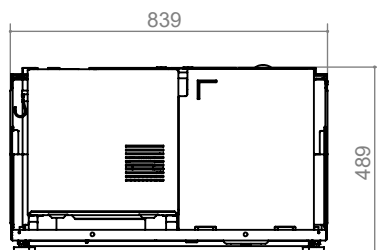

B3

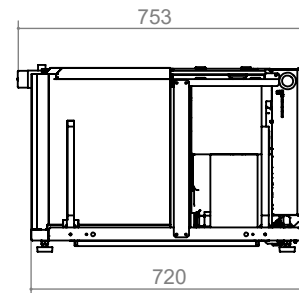

Keys: UK819474a
All dimensions in mm.

Pos.	Name
A1	Heat pump module front view
B1	Heat pump module side view from left
A2	Fan module, front view
B2	Fan module, side view from left

Pos.	Name
A3	Compact module, front view
B3	Compact module, side view from left



Connections ball valves

LWCV

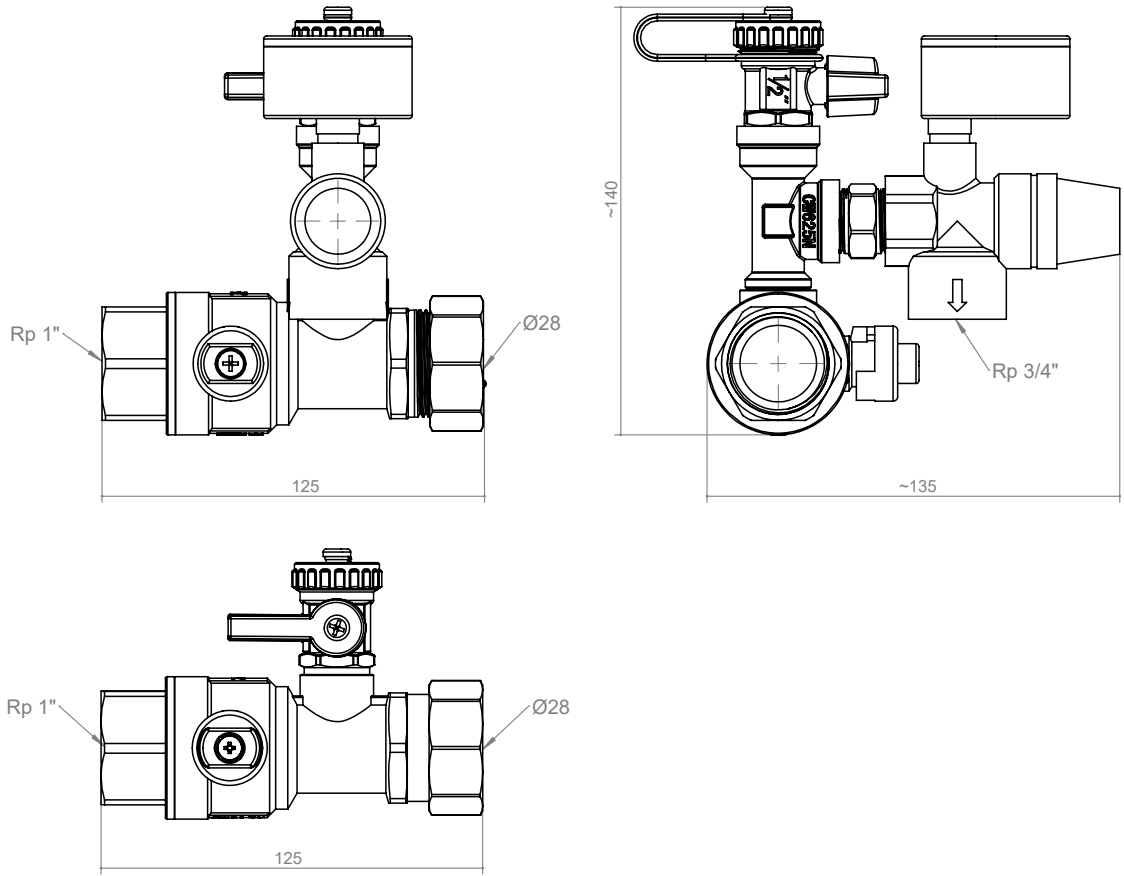

Control panel

Wall-mounting bracket

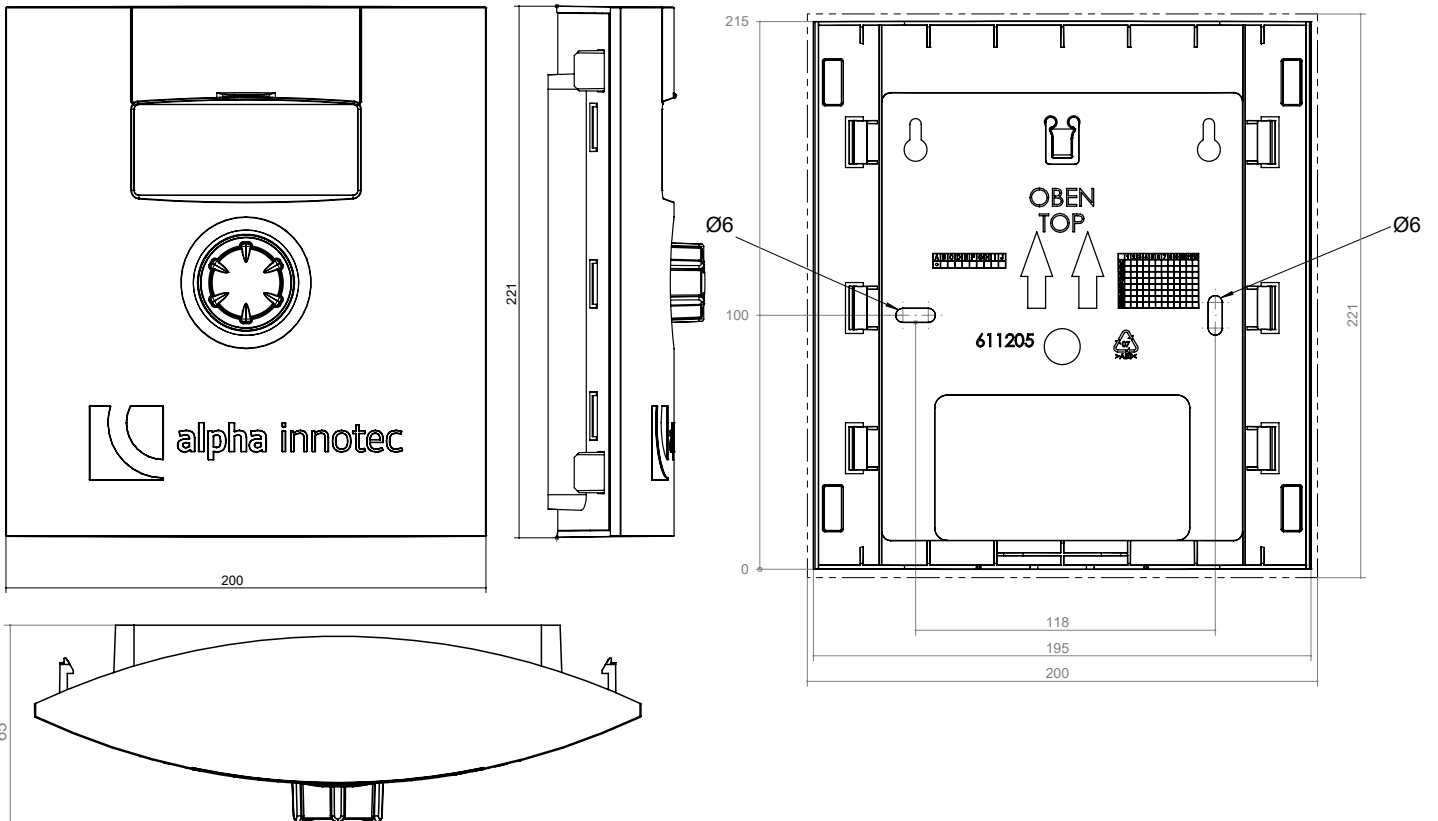



LWCV V1

Installation plan V1

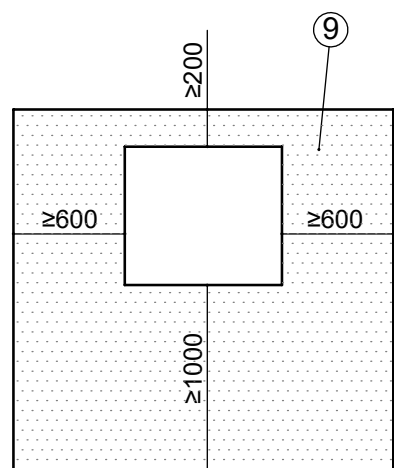
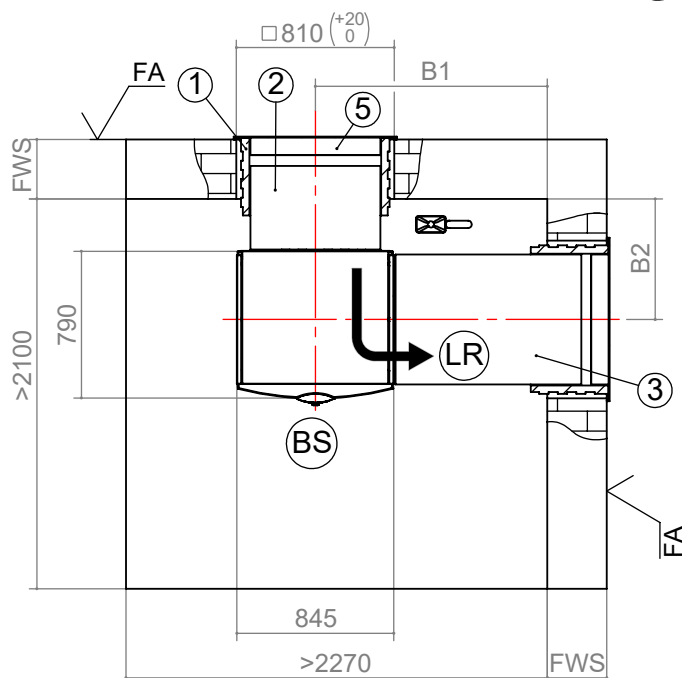
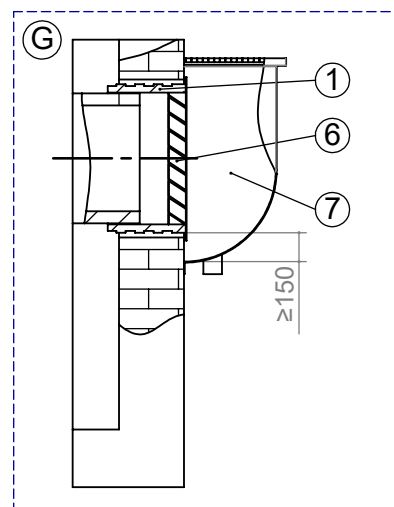
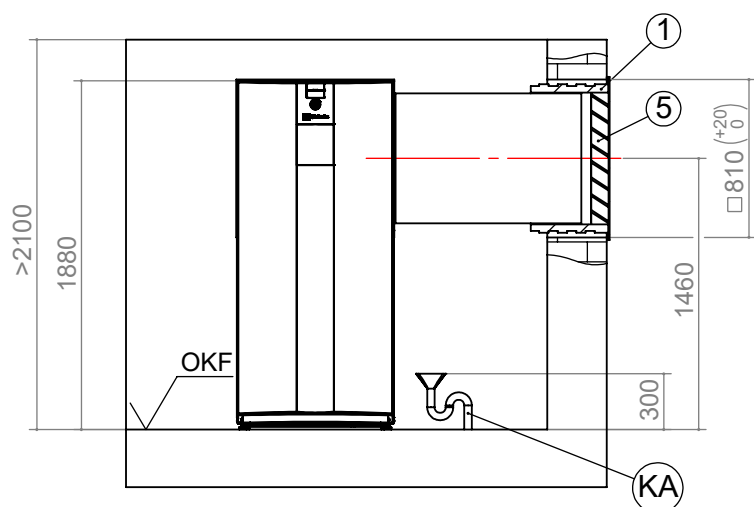

Pos.	Name	Dim.
B1	If finished wall thickness 240 to 320	1330
	If finished wall thickness 320 to 400	1250
B2	If finished wall thickness 240 to 320	730
	If finished wall thickness 320 to 400	650
1	Accessory: Wall duct 800x800x420	
2	Accessory: Air duct 700x700x450	
3	Accessory: Air duct 700x700x1000	
5	Installation above ground level Accessory: Weather protection grid 845x850	
6	Installation in the light well Accessory: Rain protection grid 845x850	
7	On site: Light well with water drain min. free cross-section 0.6 m ²	
9	Minimum clearance for service purposes If clearances are reduced to the minimum dimension, the air ducts must be shortened. This causes a substantial increase in the sound pressure level!	

Keys: 819470

All dimensions in mm.

V1	Version 1
OKF	Top edge of the finished floor
FA	Finished external façade
LR	Air direction
BS	Control side
FWS	Finished wall thickness
KA	Condensate drain
G	Cut: Installation in the light well



Installation plan V2

LWCV

V2

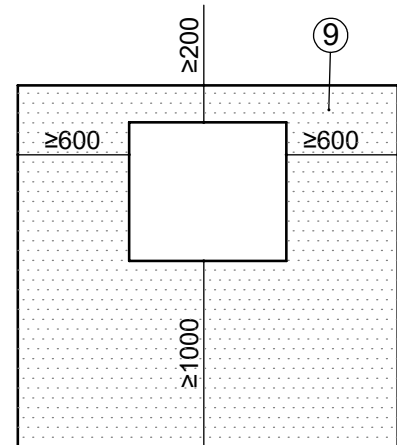
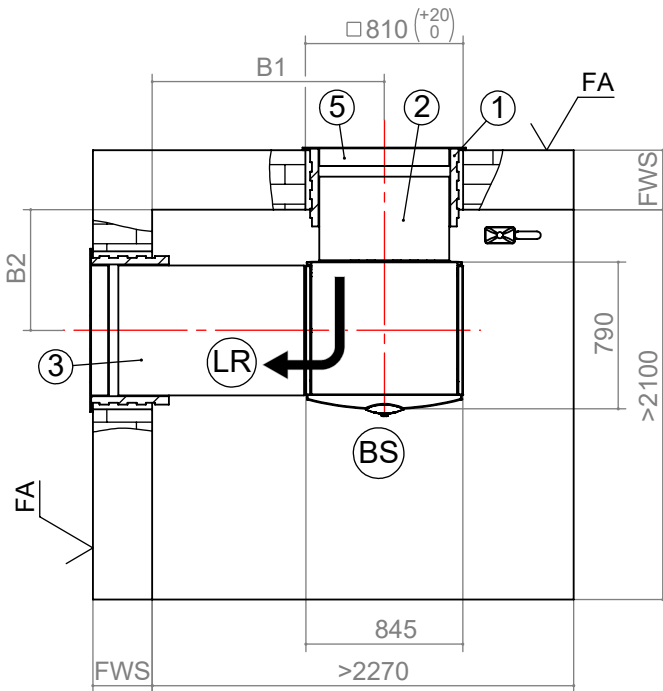
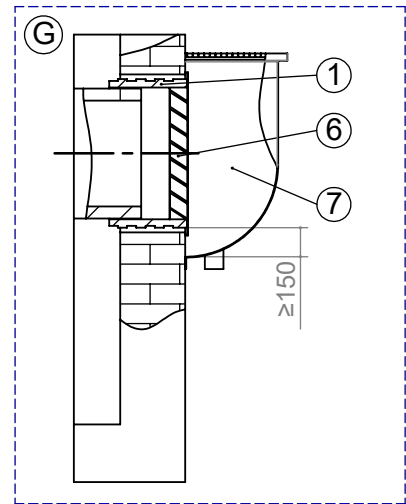
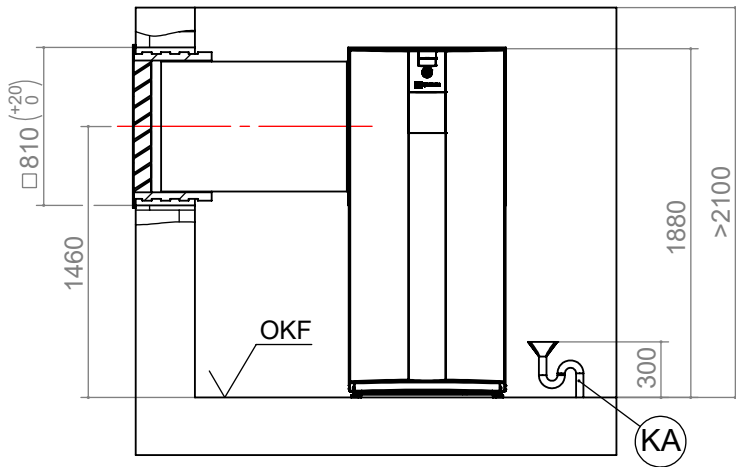

Keys: 819470
All dimensions in mm.

V2	Version 2
OKF	Top edge of the finished floor
FA	Finished external façade
LR	Air direction
BS	Control side
FWS	Finished wall thickness
KA	Condensate drain
G	Cut: Installation in the light well

Pos.	Name	Dim.
B1	If finished wall thickness 240 to 320	1330
	If finished wall thickness 320 to 400	1250
B2	If finished wall thickness 240 to 320	730
	If finished wall thickness 320 to 400	650
1	Accessory: Wall duct 800x800x420	
2	Accessory: Air duct 700x700x450	
3	Accessory: Air duct 700x700x1000	
5	Installation above ground level Accessory: Weather protection grid 845x850	
6	Installation in the light well Accessory: Rain protection grid 845x850	
7	On site: Light well with water drain min. free cross-section 0.6 m ²	
9	Minimum clearance for service purposes If clearances are reduced to the minimum dimension, the air ducts must be shortened. This causes a substantial increase in the sound pressure level!	



LWCV

Installation plan V3

V3

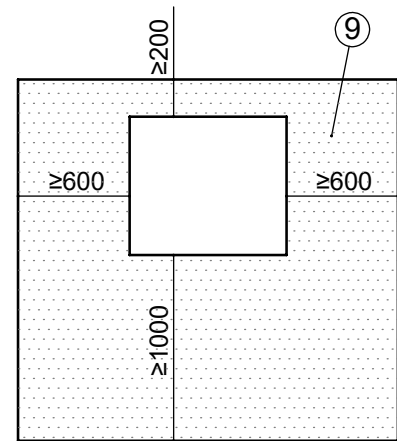
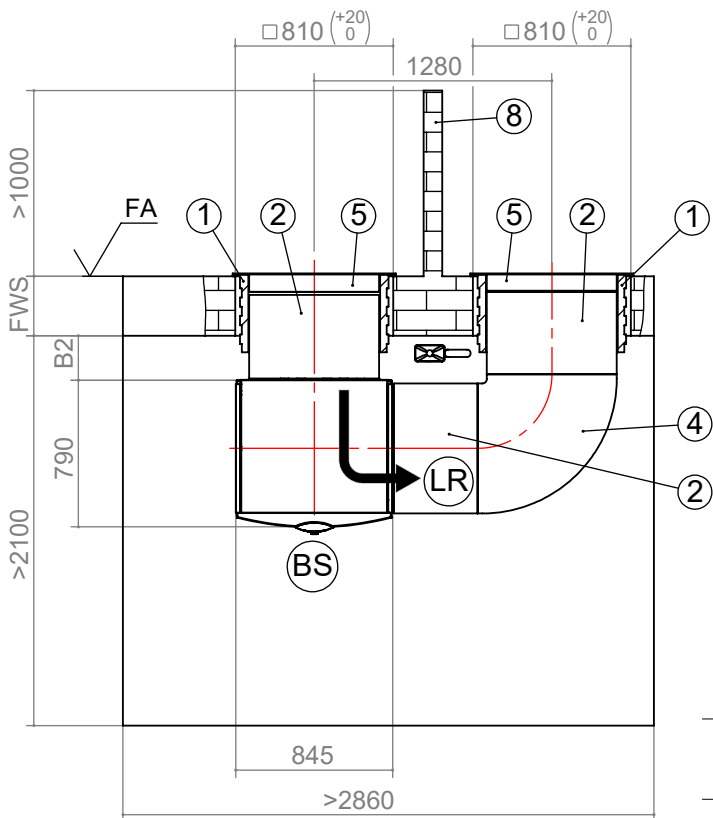
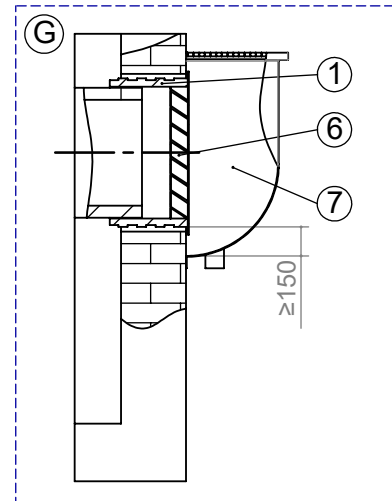
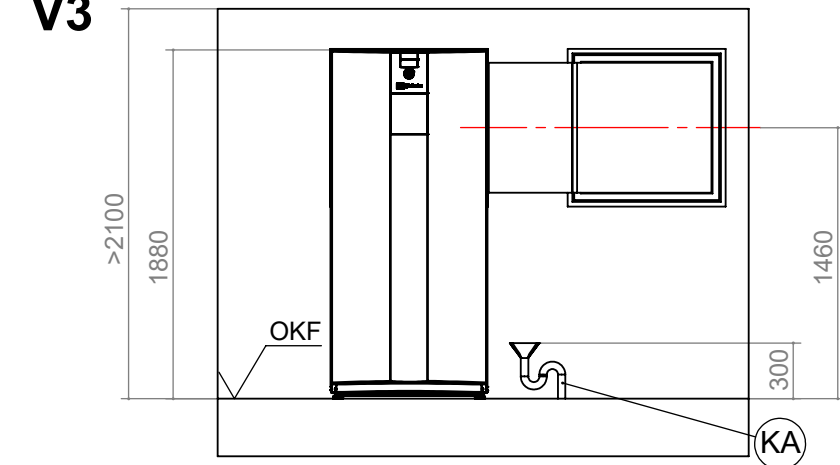

Keys: 819470

All dimensions in mm.

V3	Version 3
OKF	Top edge of the finished floor
FA	Finished external façade
LR	Air direction
BS	Control side
FWS	Finished wall thickness
KA	Condensate drain
G	Cut: Installation in the light well

Pos.	Name	Dim.
B2	If finished wall thickness 240 to 320	355
	If finished wall thickness 320 to 400	275
1	Accessory: Wall duct 800x800x420	
2	Accessory: Air duct 700x700x450	
4	Accessory: Air duct bend 700x700x750	
5	Installation above ground level Accessory: Weather protection grid 845x850	
6	Installation in the light well Accessory: Rain protection grid 845x850	
7	On site: Light well with water drain min. free cross-section 0.6 m ²	
8	Height air technical separation: if installed in light well : ≥ 1000 if installed above ground level : ≥ 1500, above weather protection grid: ≥ 300	
9	Minimum clearance for service purposes If clearances are reduced to the minimum dimension, the air ducts must be shortened. This causes a substantial increase in the sound pressure level!	



Installation plan V4

LWCV

V4

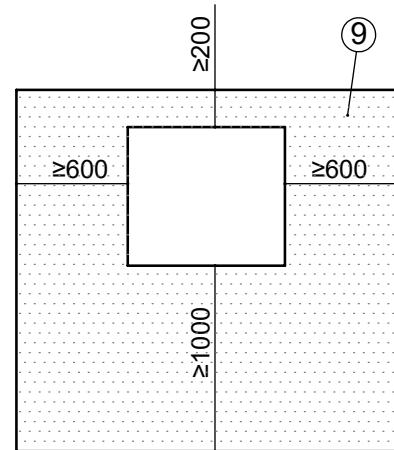
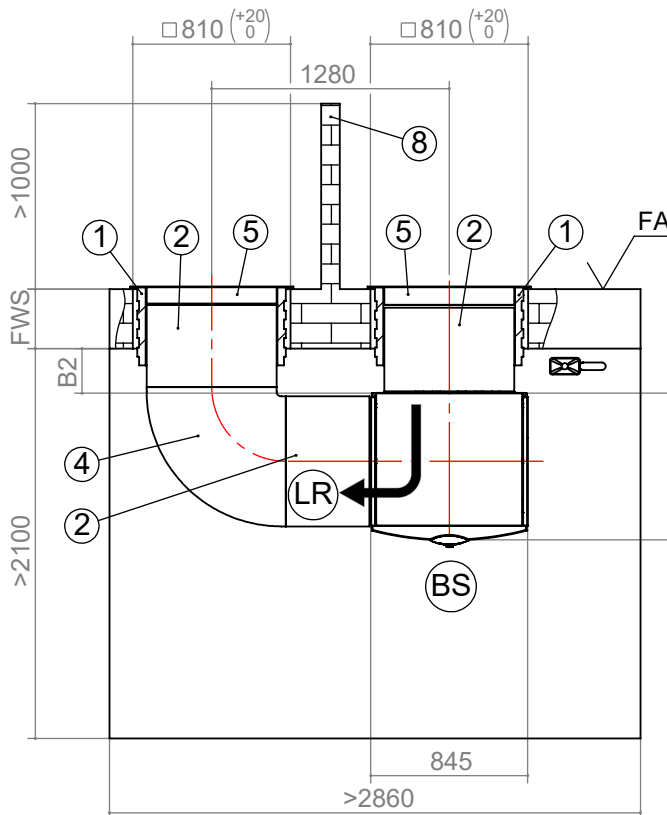
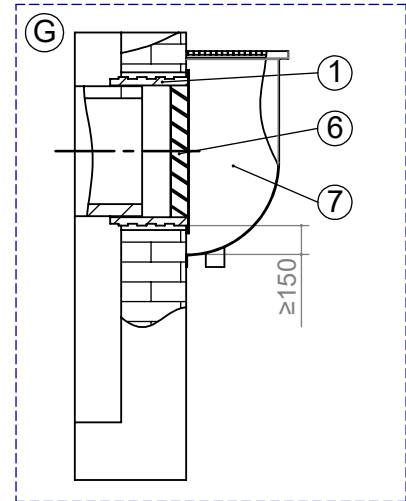
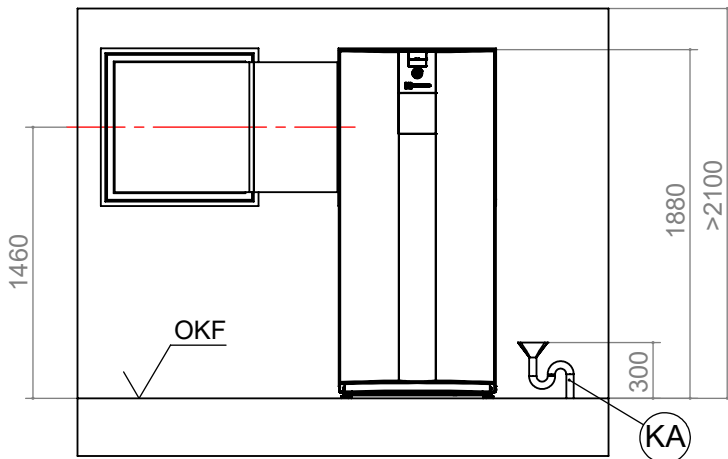

Keys: 819470
All dimensions in mm.

V4	Version 4
OKF	Top edge of the finished floor
FA	Finished external façade
LR	Air direction
BS	Control side
FWS	Finished wall thickness
KA	Condensate drain
G	Cut: Installation in the light well

Pos.	Name	Dim.
B2	If finished wall thickness 240 to 320	355
	If finished wall thickness 320 to 400	275
1	Accessory: Wall duct 800x800x420	
2	Accessory: Air duct 700x700x450	
4	Accessory: Air duct bend 700x700x750	
5	Installation above ground level Accessory: Weather protection grid 845x850	
6	Installation in the light well Accessory: Rain protection grid 845x850	
7	On site: Light well with water drain min. free cross-section 0.6 m ²	
8	Height air technical separation: if installed in light well : ≥ 1000 if installed above ground level : ≥ 1500, above weather protection grid: ≥ 300	
9	Minimum clearance for service purposes If clearances are reduced to the minimum dimension, the air ducts must be shortened. This causes a substantial increase in the sound pressure level!	



LWCV V5

Installation plan V5

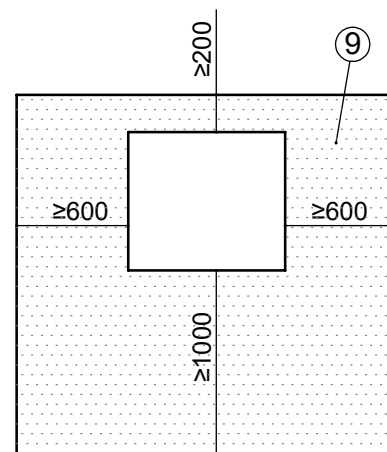
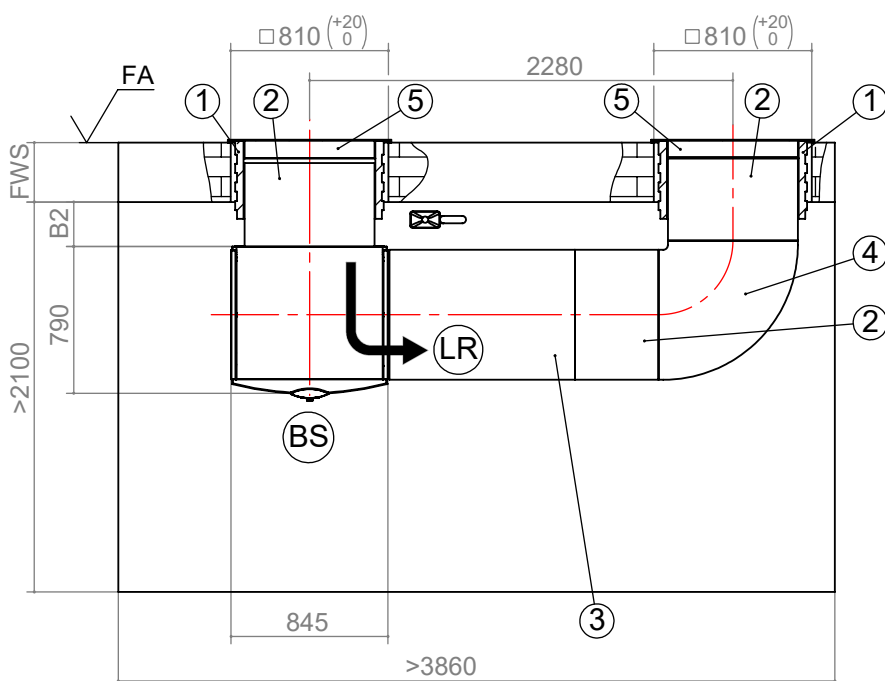
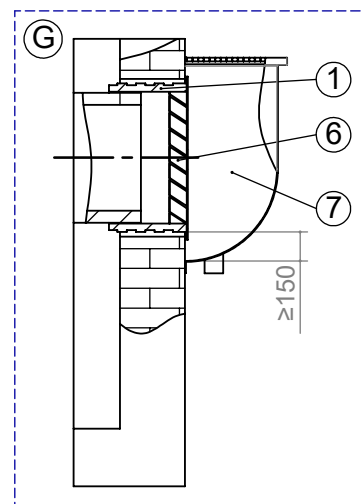
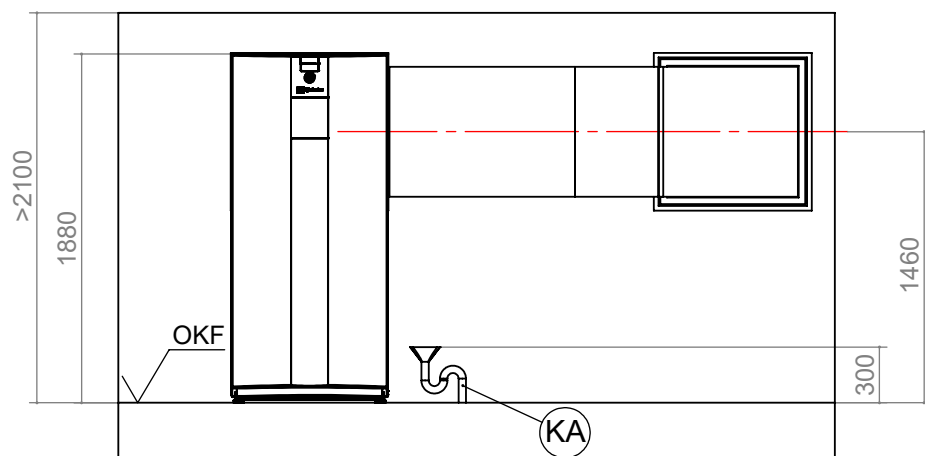

Keys: 819470

All dimensions in mm.

V5	Version 5
OKF	Top edge of the finished floor
FA	Finished external façade
LR	Air direction
BS	Control side
FWS	Finished wall thickness
KA	Condensate drain
G	Cut: Installation in the light well

Pos.	Name	Dim.
B2	If finished wall thickness 240 to 320	355
	If finished wall thickness 320 to 400	275
1	Accessory: Wall duct 800x800x420	
2	Accessory: Air duct 700x700x450	
3	Accessory: Air duct 700x700x1000	
4	Accessory: Air duct bend 700x700x750	
5	Installation above ground level Accessory: Weather protection grid 845x850	
6	Installation in the light well Accessory: Rain protection grid 845x850	
7	On site: Light well with water drain min. free cross-section 0.6 m ²	
9	Minimum clearance for service purposes If clearances are reduced to the minimum dimension, the air ducts must be shortened. This causes a substantial increase in the sound pressure level!	



Installation plan V6

LWCV

V6

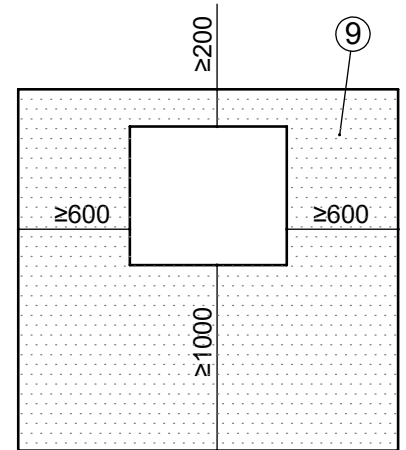
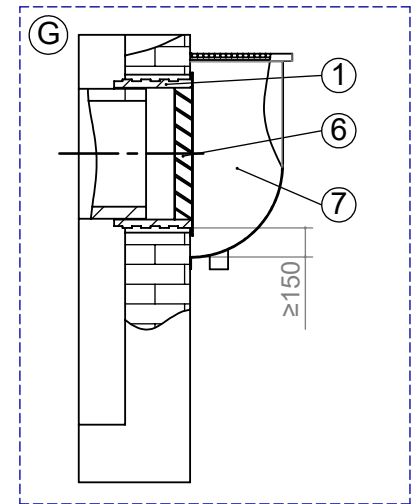
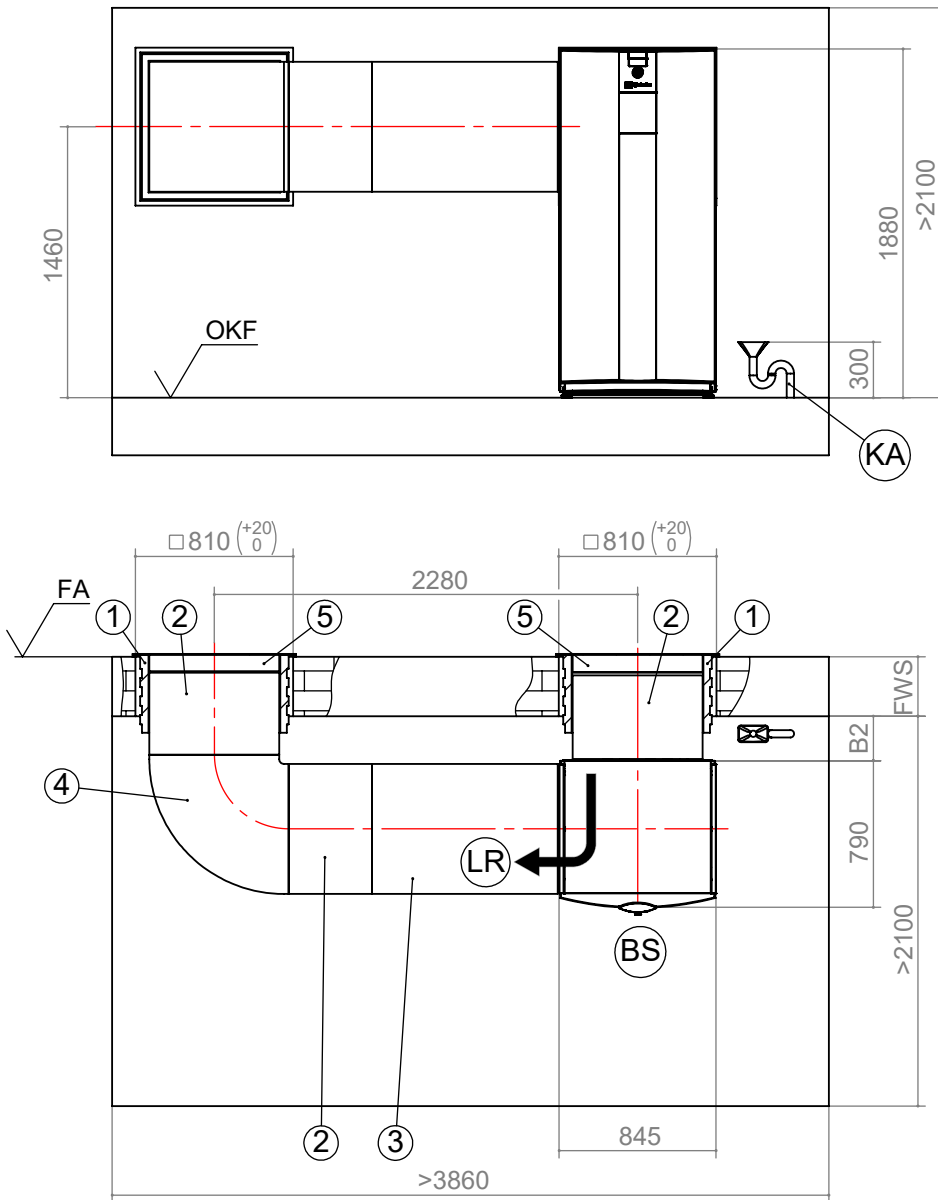

Keys: 819470
All dimensions in mm.

V6	Version 6
OKF	Top edge of the finished floor
FA	Finished external façade
LR	Air direction
BS	Control side
FWS	Finished wall thickness
KA	Condensate drain
G	Cut: Installation in the light well

Pos.	Name	Dim.
B2	If finished wall thickness 240 to 320	355
	If finished wall thickness 320 to 400	275
1	Accessory: Wall duct 800x800x420	
2	Accessory: Air duct 700x700x450	
3	Accessory: Air duct 700x700x1000	
4	Accessory: Air duct bend 700x700x750	
5	Installation above ground level Accessory: Weather protection grid 845x850	
6	Installation in the light well Accessory: Rain protection grid 845x850	
7	On site: Light well with water drain min. free cross-section 0.6 m ²	
9	Minimum clearance for service purposes If clearances are reduced to the minimum dimension, the air ducts must be shortened. This causes a substantial increase in the sound pressure level!	



LWCV

V7

Installation plan V7

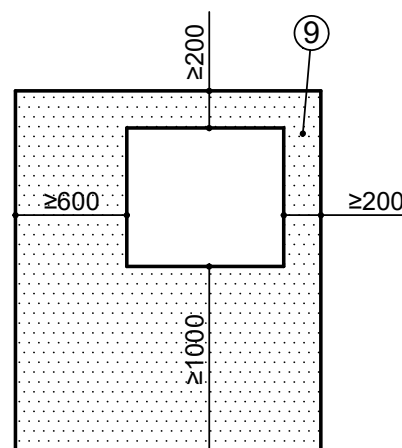
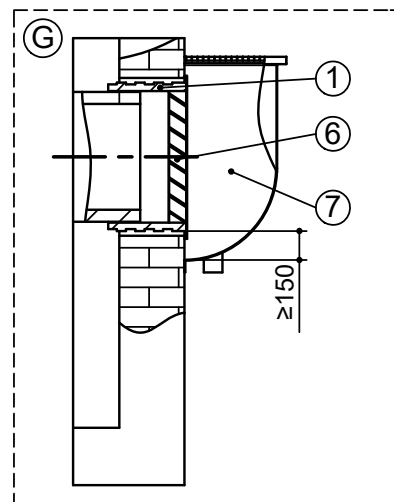
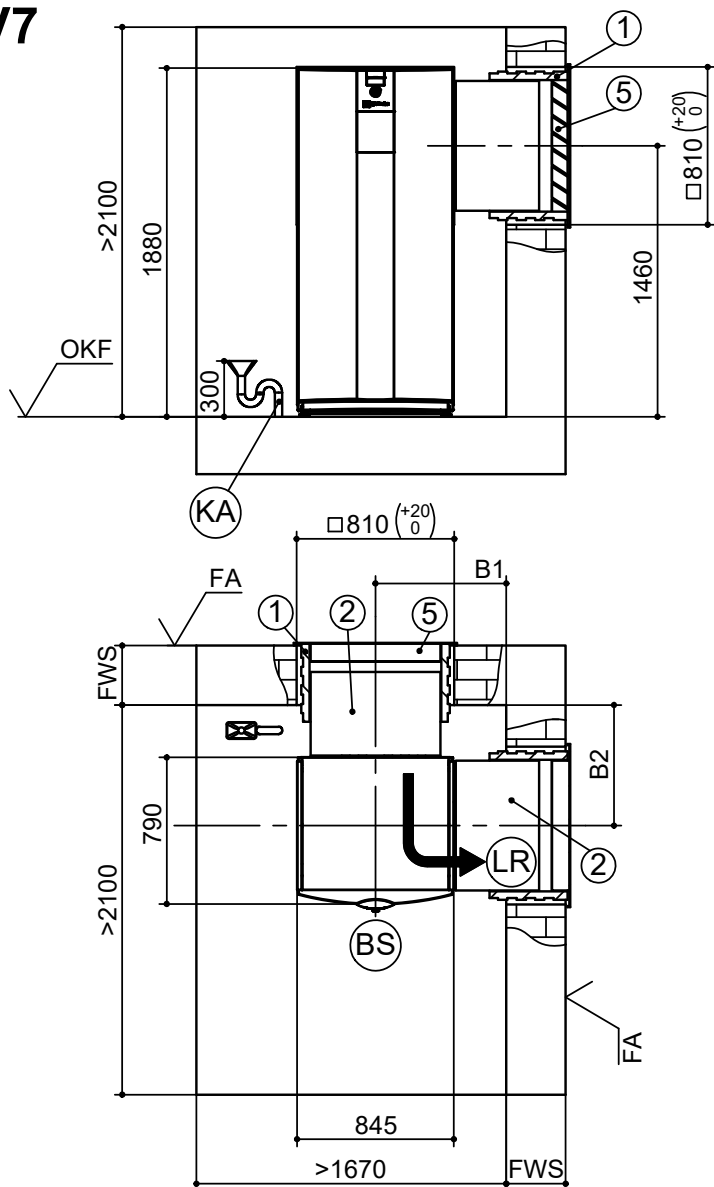

Keys: 819470

All dimensions in mm.

V7	Version 7
OKF	Top edge of the finished floor
FA	Finished external façade
LR	Air direction
BS	Control side
FWS	Finished wall thickness
KA	Condensate drain
G	Cut: Installation in the light well

Pos.	Name	Dim.
B1	If finished wall thickness 240 to 320	760
	If finished wall thickness 320 to 400	680
B2	If finished wall thickness 240 to 320	730
	If finished wall thickness 320 to 400	650
1	Accessory: Wall duct 800x800x420	
2	Accessory: Air duct 700x700x450	
5	Installation above ground level Accessory: Weather protection grid 845x850	
6	Installation in the light well Accessory: Rain protection grid 845x850	
7	On site: Light well with water drain min. free cross-section 0.6 m ²	
9	Minimum clearance for service purposes If clearances are reduced to the minimum dimension, the air ducts must be shortened. This causes a substantial increase in the sound pressure level!	

Space-saving installation

If space-saving installation is chosen, access to the devices is limited on the air outlet side, which restricts the ease of installation and servicing. For more complex service tasks, it may be necessary to remove the device. Higher sound levels are to be expected.



Installation plan V8

LWCV

V8

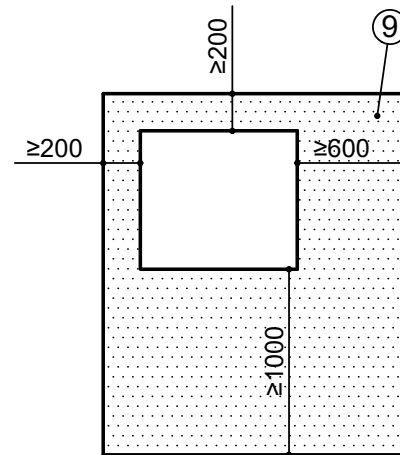
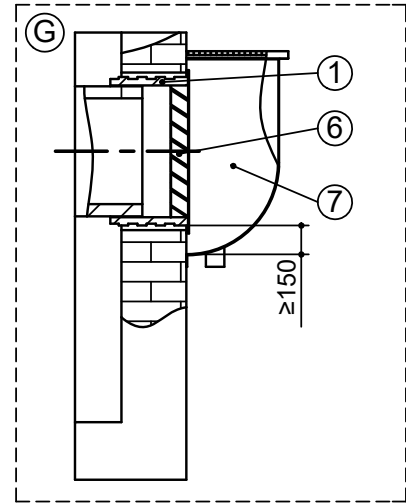
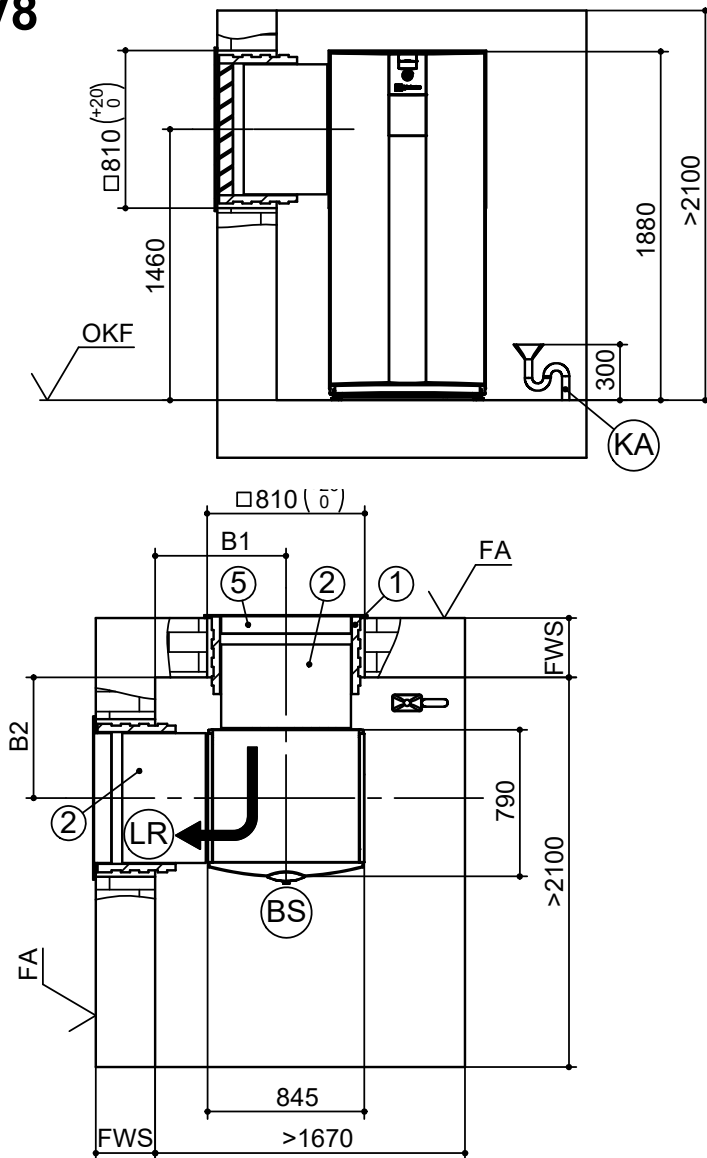

Keys: 819470

All dimensions in mm.

V8	Version 8
OKF	Top edge of the finished floor
FA	Finished external façade
LR	Air direction
BS	Control side
FWS	Finished wall thickness
KA	Condensate drain
G	Cut: Installation in the light well

Pos.	Name	Dim.
B1	If finished wall thickness 240 to 320	760
	If finished wall thickness 320 to 400	680
B2	If finished wall thickness 240 to 320	730
	If finished wall thickness 320 to 400	650
1	Accessory: Wall duct 800x800x420	
2	Accessory: Air duct 700x700x450	
5	Installation above ground level Accessory: Weather protection grid 845x850	
6	Installation in the light well Accessory: Rain protection grid 845x850	
7	On site: Light well with water drain min. free cross-section 0.6 m ²	
9	Minimum clearance for service purposes If clearances are reduced to the minimum dimension, the air ducts must be shortened. This causes a substantial increase in the sound pressure level!	

Space-saving installation

If space-saving installation is chosen, access to the devices is limited on the air outlet side, which restricts the ease of installation and servicing. For more complex service tasks, it may be necessary to remove the device. Higher sound levels are to be expected.



IMPORTANT

The minimum distances necessary for correct and safe operation as well as any service work must be observed.

- ✓ Air intake on the side facing away from the coast / from the prevailing wind direction
- ✓ Air outlet not on the side facing the coast / prevailing wind direction

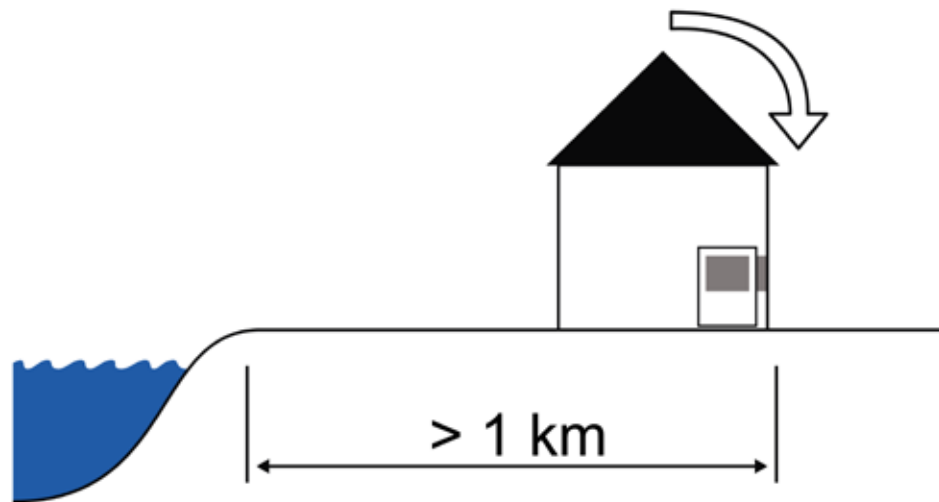



Hydraulic integration with buffer tank in series

LWCV

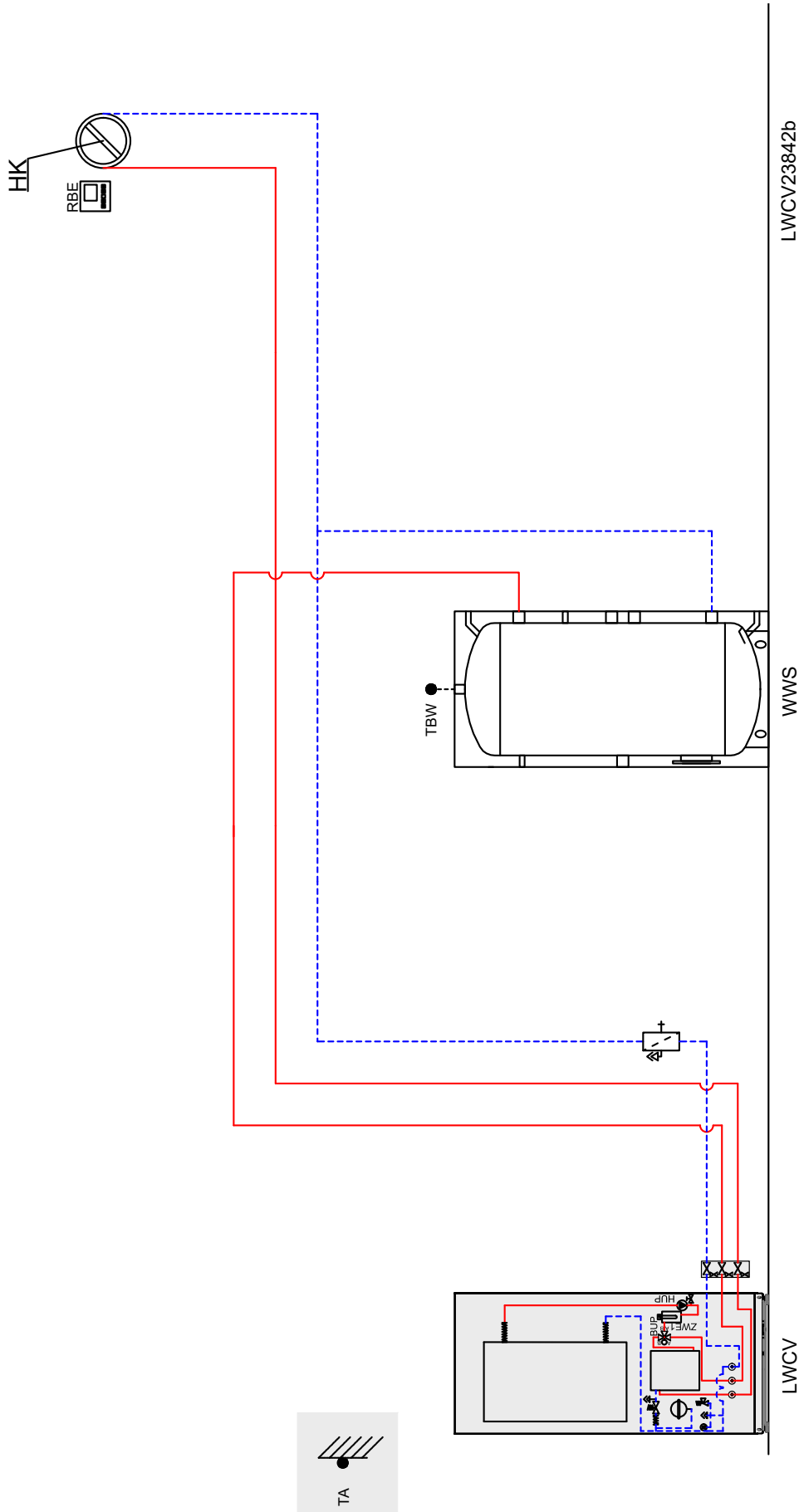

NOTE This schematic diagram is an example of a system without shut-off and safety devices, and it does not replace the technical planning and design on site. All regional standards, laws and regulations must be observed. The pipe dimensions must be carefully planned and designed.





LWCV

Hydraulic integration with separation tank

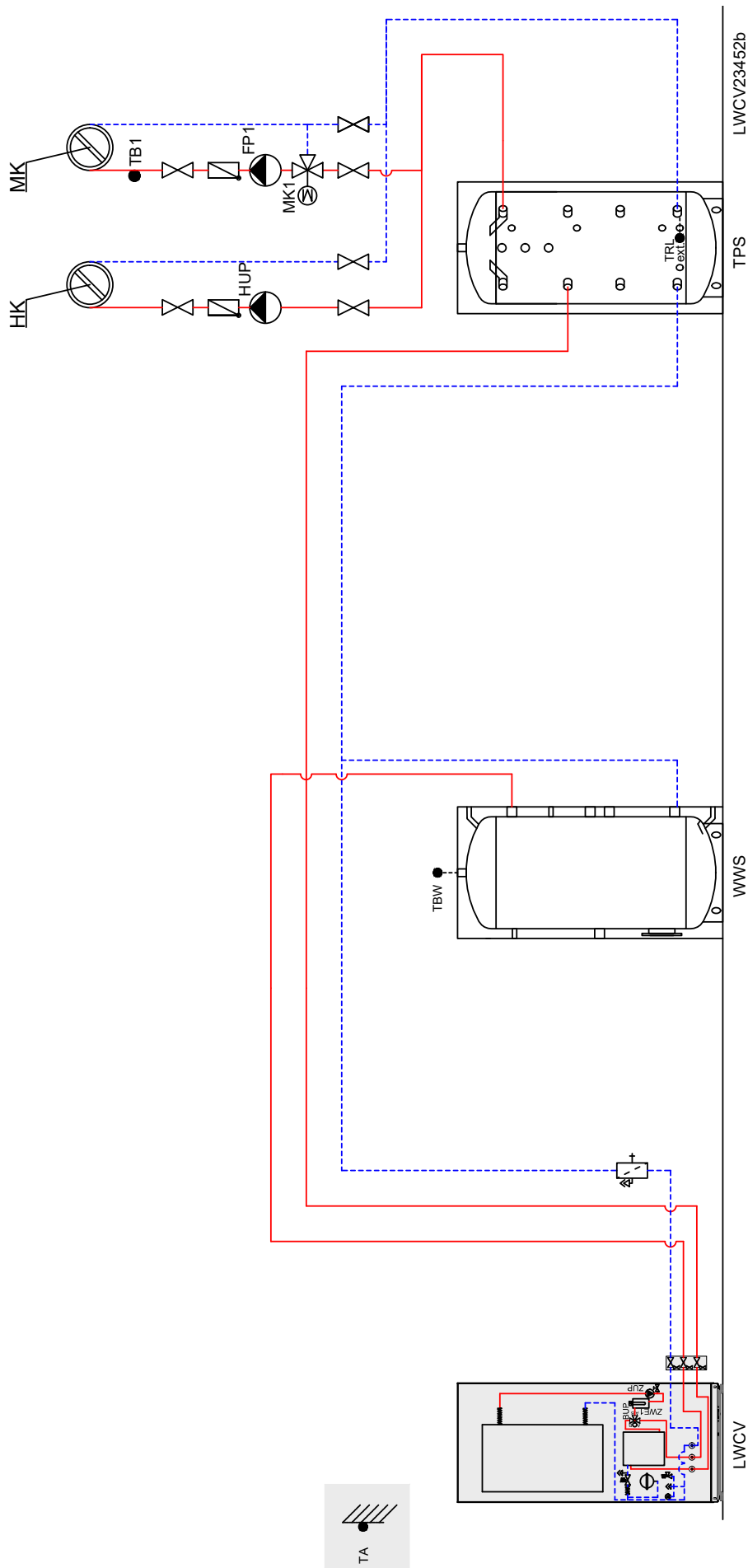

NOTE
 This schematic diagram is an example of a system without shut-off and safety devices, and it does not replace the technical planning and design on site. All regional standards, laws and regulations must be observed. The pipe dimensions must be carefully planned and designed.



	Vibration isolation		Gas- or oil-boiler
	Shut-off device and drainage		Wood boiler
	Shut-off device with dirt trap		Brine pressure switch
	Safety group		Swimming pool heat exchanger
	Shut-off device		Separation heat exchanger / intermediate heat exchanger
	Circulation pump		Solar domestic hot water tank
	Non return valve/ one way valve		Pipe lead-in
	Overflow valve		Fresh water station (TWS)
	Membrane expansion vessel		Room control unit
	Second heat generator (ZWE)		Dew-point monitor
	3-way mixing valve / switching valve		Supply heat pump
	4-way mixing valve / switching valve		Circulation pump / switching valve domestic hot water
	Dirt-trap		Mixer circuit 1/2/3 (heating or cooling function)
	Wall breakthrough		Circulation pump heating circuit
	Brine manifold		Circulation pump / switching valve
	Ground slinkies		Feed circulating pump
	Ground collector		Circulation pump
	Flow switch		Domestic hot water charging pump
	Groundwater spring pump with flow direction groundwater		Heat source circulation pump
	Buffer tank: - TPS Stratified storage tank - RPS Series buffer tank - TPSK Stratified storage tank (cooling) - WTPSK Stratified storage tank, wall-mounted (cooling)		Outdoor temperature sensor
	Multifunction tank		Sensor domestic hot water
	Domestic hot water tank		Sensor mixer circuit
	Volume flow meter		Sensor external return
	Heat meter		Sensor return

Split:	Switching valve domestic hot water / heating
QN10	Switching valve cooling / heating
QN12	Mixing valve additional heating
QN11	Circulation pump
GP12	Outdoor temperature sensor
BT1	upper domestic hot water (displayed value)
BT7	Sensor return
BT3	Sensor domestic hot water
BT6	Flow sensor cooling
BT15	Temperature sensor, liquid state
BT25	Flow temperature heating
BT71	Return temperature heating / cooling
BT52	Sensor heating boiler
BT50	Room temperature sensor
XL1	Flow heating
XL2	Return heating / cooling
XL3	Cold water
XL4	Domestic hot water
XL5	Circulation
XI10	Flow cooling
XL13	Liquid refrigerant
XL14	Gaseous refrigerant
XL18	Flow second heat generator
XL19	Return second heat generator
X2	Terminal second heat generator
EP Split	Expansion board Split

(not included in scope of delivery)

Controls supplied by customer / on-site components:
 Parts and components shown in the colour "grey" must be provided by the customer and also operated with a regulation provided by the customer.
 The temperature difference control SLP of the additional board is excepted from this.

General:
 Pipes, fittings and fixtures must be designed and insulated in accordance with the current and valid standards, guidelines and recognised rules of technology (e.g.: vapour diffusion-tight insulation if the temperature falls below the dew point).





Terminal diagram 1/2

LWCV

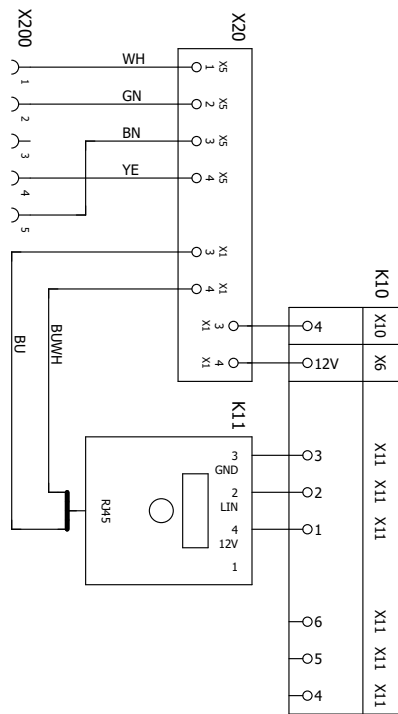
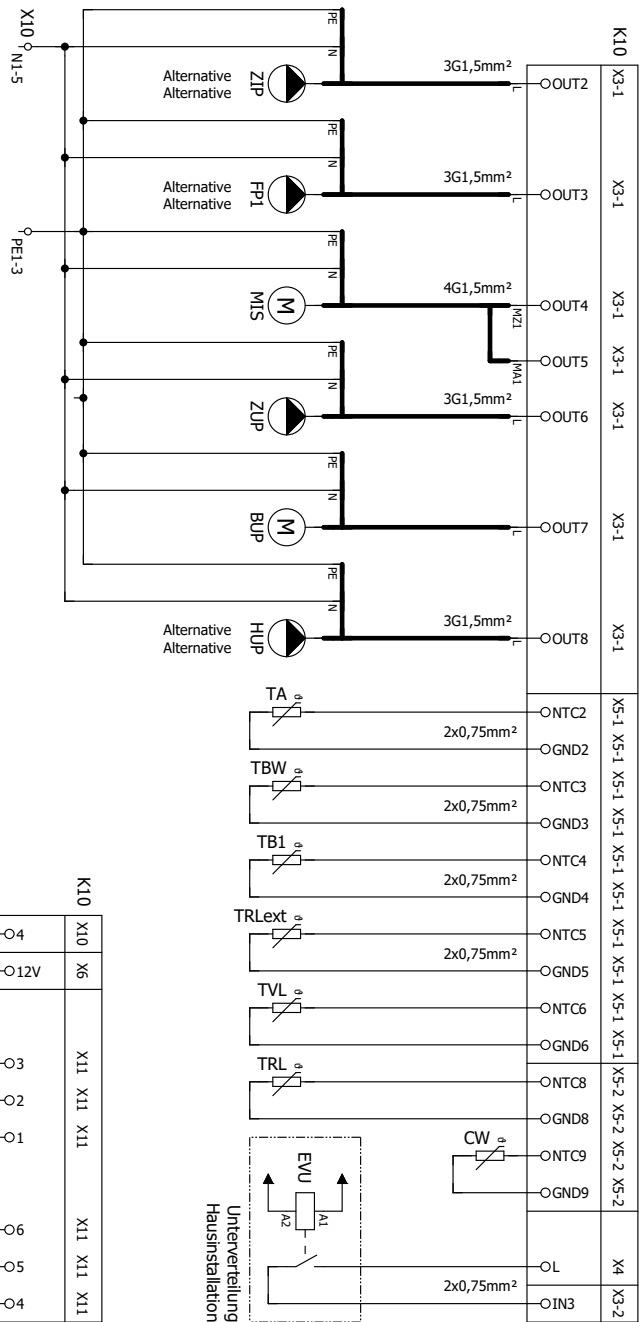
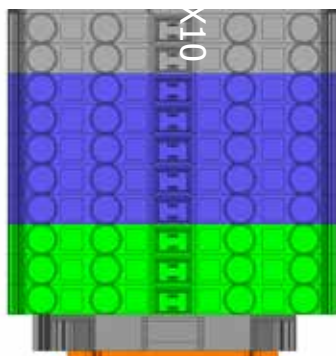
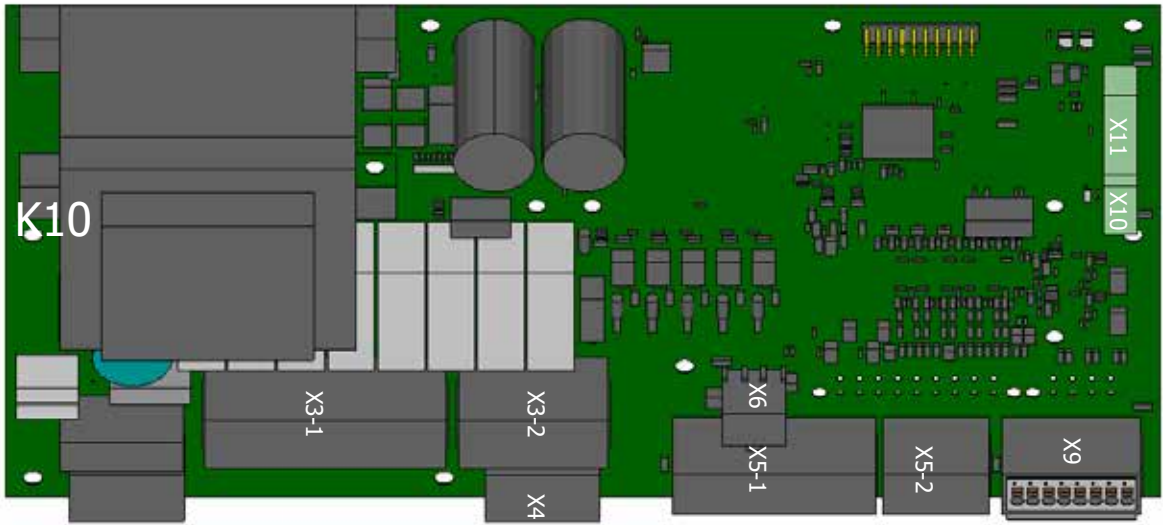

IMPORTANT

The cable cross-sections shown are only intended as a guideline for the electrician! They must be adapted to the regional regulations and the conditions of use (e.g. cable length, current carrying capacity, ambient temperature, type of installation)!

UK
831220a

Refer to protection notice ISO 16016.



Terminal diagram 2/2

LWCV

UK 831220a

Equipment	Description	Wired
PEX	Party external	
TA	Outdoor temperature sensor	
TBW	Domestic hot water temperature sensor / domestic hot water thermostat	
TB1	Temperature sensor, mixing circuit 1	
TR1ext.	Temperature sensor, external return	
TVL	Temperature sensor supply	
TRL	Temperature sensor, return	
CW	Coding resistor	
STB / ZWE	Safety temperature limiter / additional heating generator	
EVU / SG 1	Block by power supply company (jumper if no blocking time) / Smart Grid control 1	X
SG 2	Smart Grid control 2	X
ZWE1	Zusätzlicher Wärmeerzeuger 1	
ZIP / KS / BLP	Domestic hot water circulation pump / cooling signal / domestic hot water charge pump	
FP 1 / ZWE 2 / SST	Mixing circuit 1 circulation pump / Additional heating generator 2 / Collective fault	
MIS (MZ1)	Mixing circuit 1 closed (discharge mixer / cooling mixer / charge mixer)	
MIS (MA1)	Mixing circuit 1 open (discharge mixer / cooling mixer / charge mixer)	
ZUP	Additional (feeder) circulation pump	
BLP	Domestic hot water circulation pump / Domestic hot water switching valve	
HLP	Heating circuit circulation pump	X
VBO	Fan / Brine circulation pump / Well circulation pump	
B2	Volumetric flow meter	X
K10	Controller circuit board; Caution: I max = 6.3A/230VAC	X
K11	Control panel	X
X10	Control voltage feed	X
X20	MODBUS circuit board	X
X200	MODBUS	X

Refer to protection notice ISO 16016.



Terminal diagram, mains connection LWCV 82R1/3 1~230V + electric heating element 3~400V

LWCV

0	1	2	3	4	5	6	7	8	9
---	---	---	---	---	---	---	---	---	---

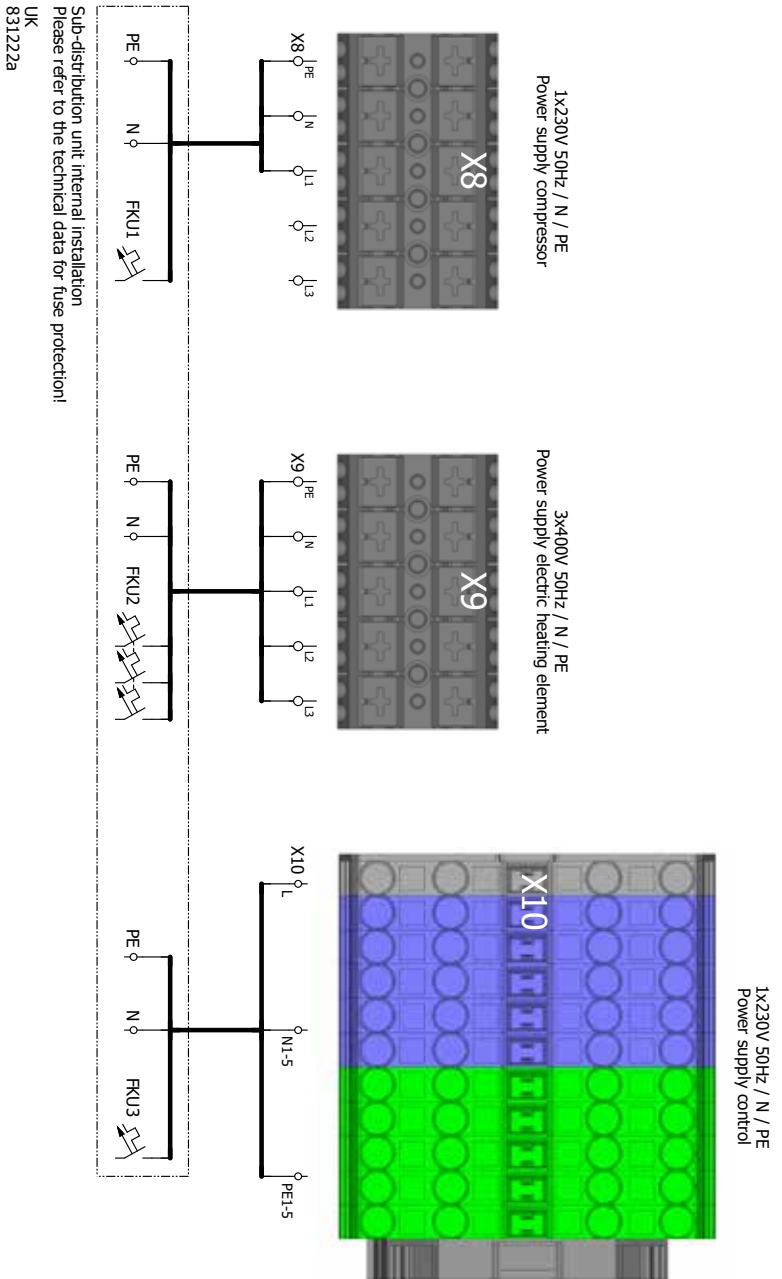

Equipment	Description
FKU1	Circuit breaker compressor
FKU2	Circuit breaker electric heating element
FKU3	Circuit breaker control
X8	Terminal for compressor
X9	Terminal for electric heating element
X10	Terminal for control



LWCV

Terminal diagram, mains connection LWCV 82R1/3 1~230V + electric heating element 1~230V

0	1	2	3	4	5	6	7	8	9
---	---	---	---	---	---	---	---	---	---

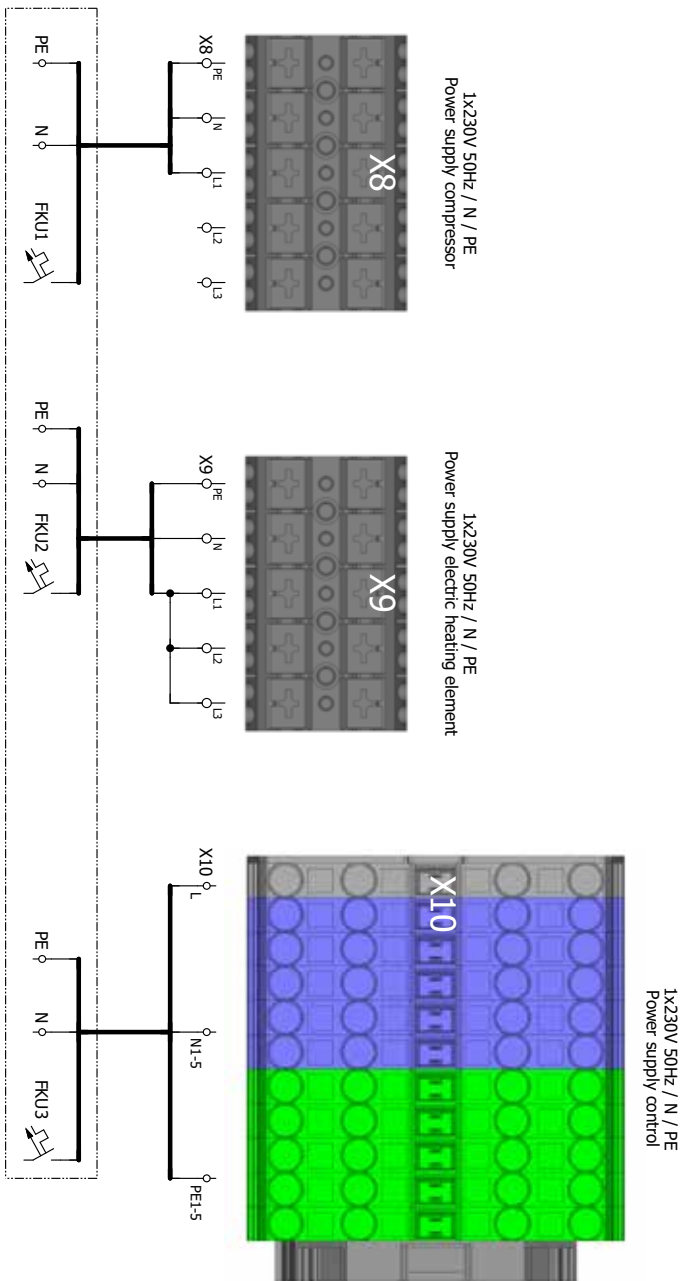

Equipment	Description
FKU1	Circuit breaker compressor
FKU2	Circuit breaker electric heating element
FKU3	Circuit breaker control
X8	Terminal for compressor
X9	Terminal for electric heating element
X10	Terminal for control

Refer to protection notice ISO 16016.



Terminal diagram, mains connection LWCV 122R3 3~400V + electric heating element 3~400V

LWCV

0	1	2	3	4	5	6	7	8	9
---	---	---	---	---	---	---	---	---	---

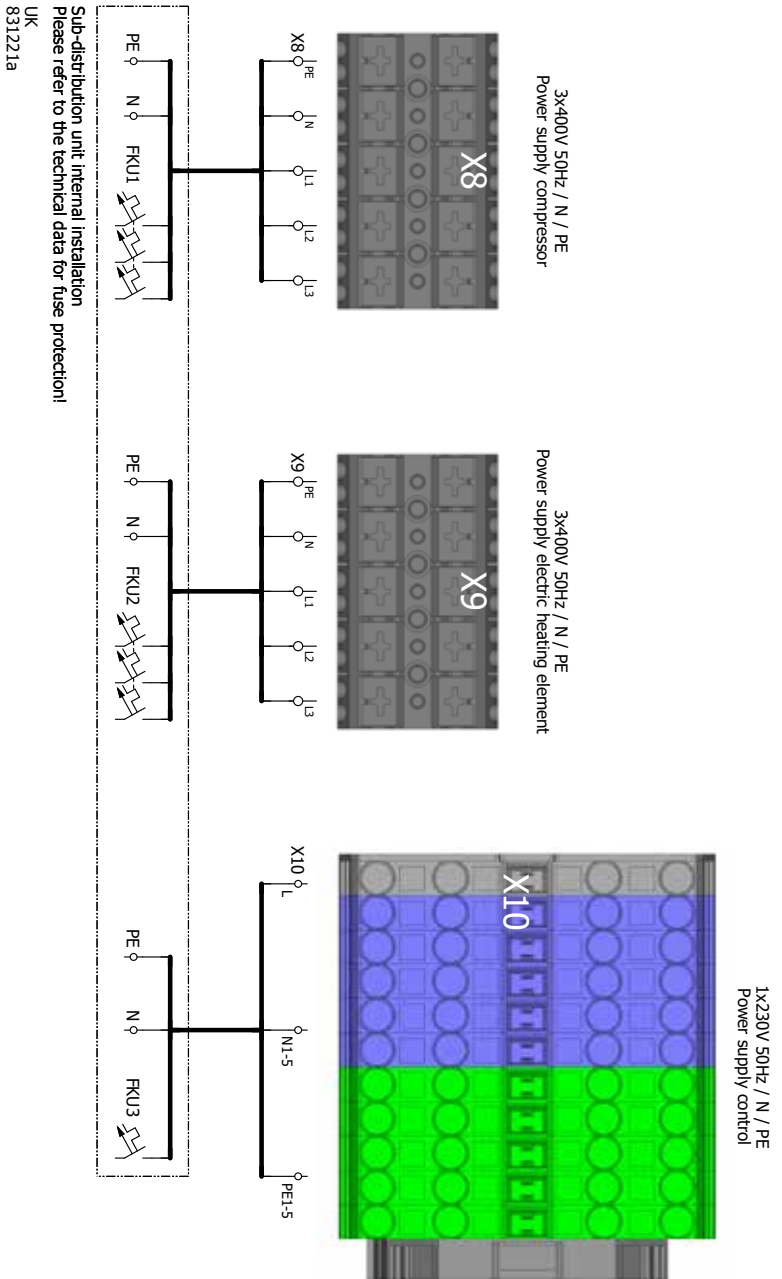

Equipment	Description
FKU1	Circuit breaker compressor
FKU2	Circuit breaker electric heating element
FKU3	Circuit breaker control
X8	Terminal for compressor
X9	Terminal for electric heating element
X10	Terminal for control



LWCV Compact modul

Circuit diagram 1/4

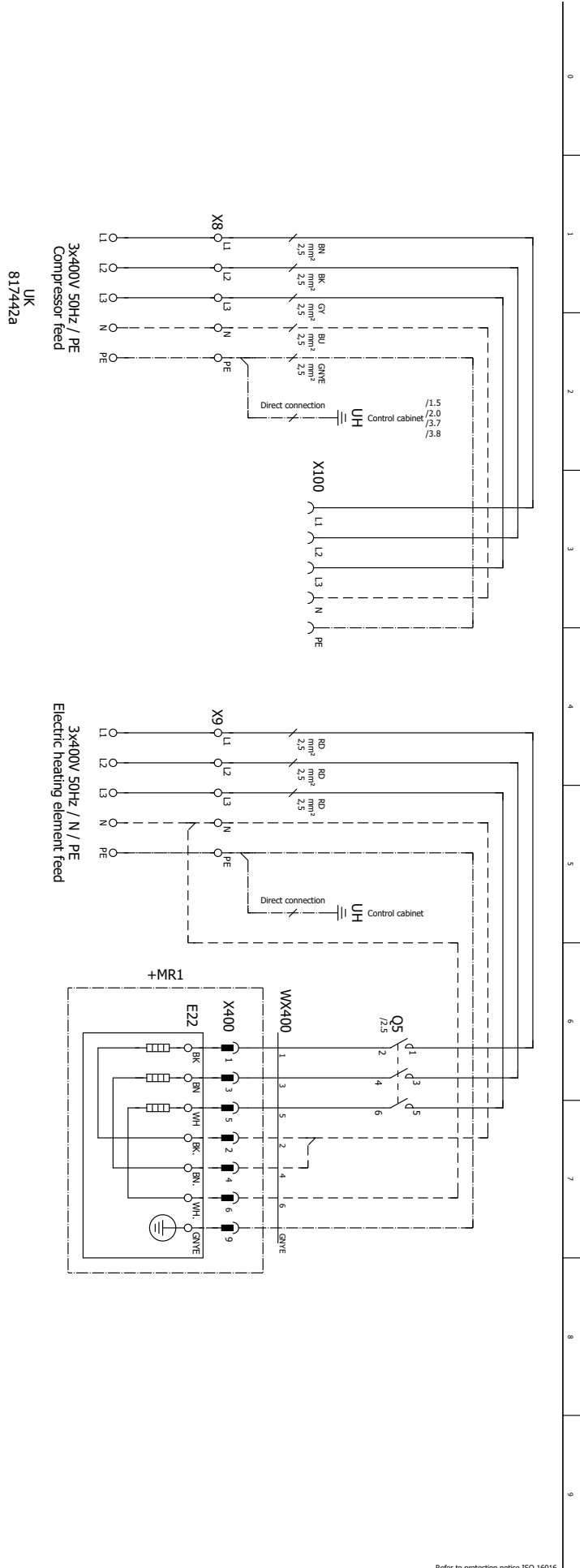

Refer to protection notice ISO 16016.



Circuit diagram 2/4

LWCV Compact modul

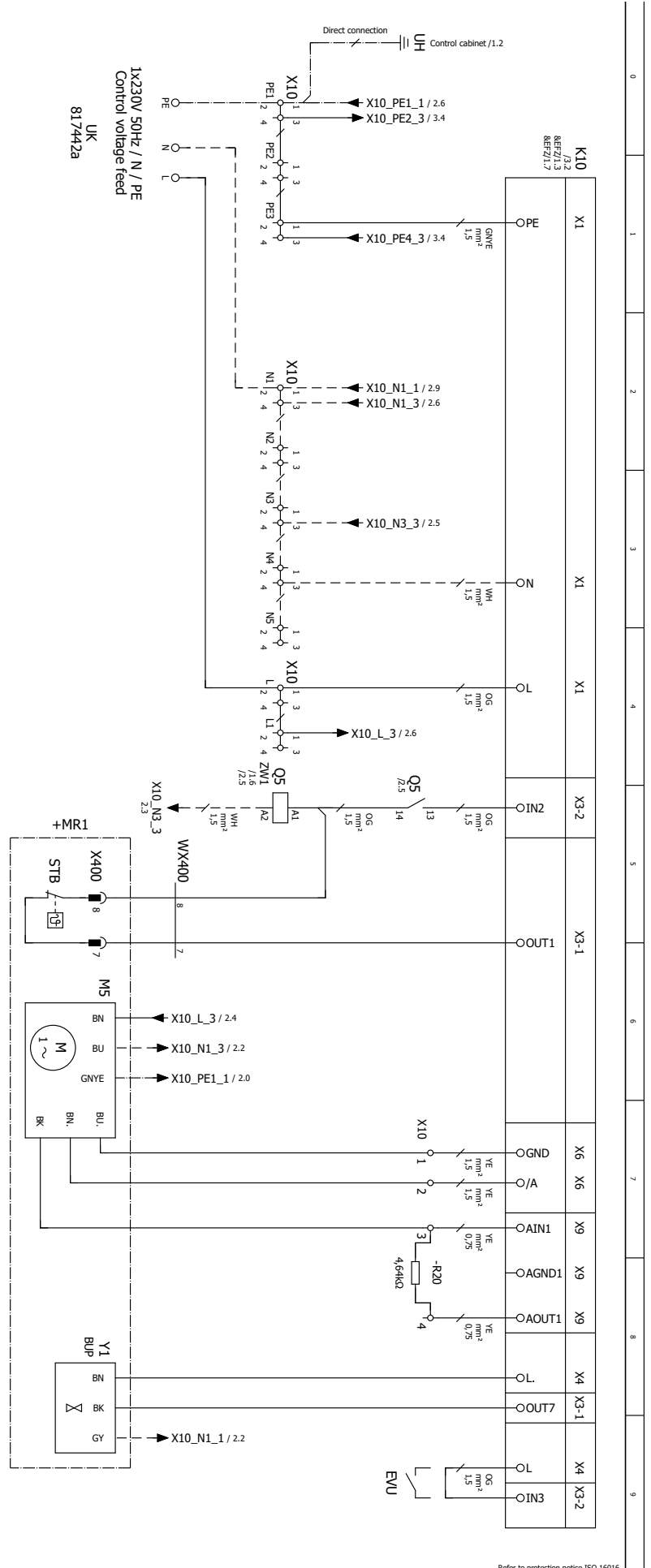

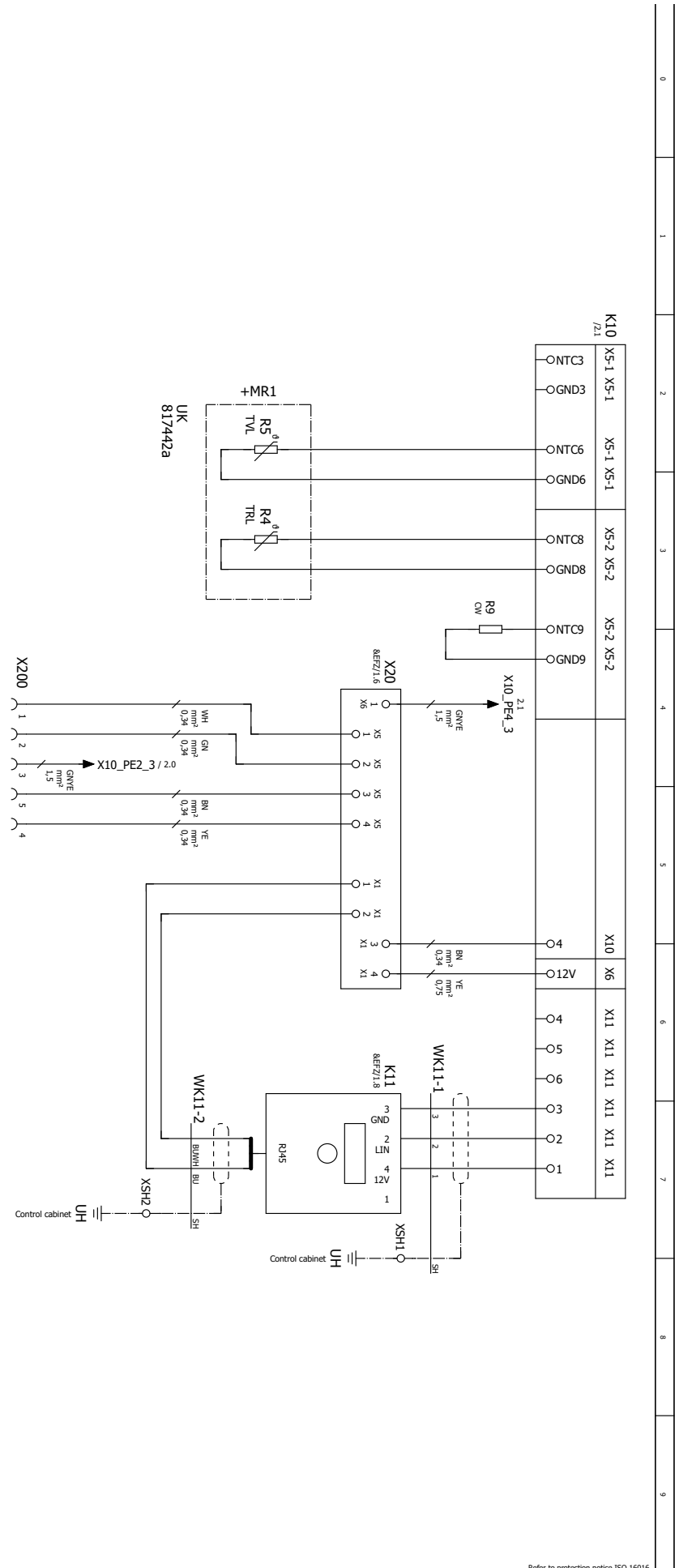



Circuit diagram 4/4

LWCV Compact modul

UK 817442a

Equipment	Description
E22	Electric heating element
EVU / SG 1	Block by power supply company (Jumper if no blocking time) / Smart Grid control 1
K10	Controller circuit board; Caution: I max = 6.3A/230VAC
K11	Control panel
M5	Heating circuit circulation pump
Q5	Electric heating element contactor
R3	Domestic hot water temperature sensor / domestic hot water thermostat
R4	Temperature sensor, return
R5	Temperature sensor supply
R9	Coding resistor; CMD6 12,1kOhm; CMD9 12,7kOhm
STB	Electric heating element temperature shutdown
WK11-1	Control panel connection cable
WK11-2	Control panel connection cable
WX400	Connection Electric heating element
X8	Compressor feed
X9	Electric heating element feed
X10	Control voltage feed
X20	MODBUS circuit board
X100	Power supply WP
X200	MODBUS
X300	Power supply controller 230V
X400	Electric heating element feed
XSH	Control panel shielding terminal
Y1	Domestic hot water valve
+MR1	Machine room

Refer to protection notice ISO 16016.



LWCV 82R1/3 Heat pump module

Circuit diagram 1/5

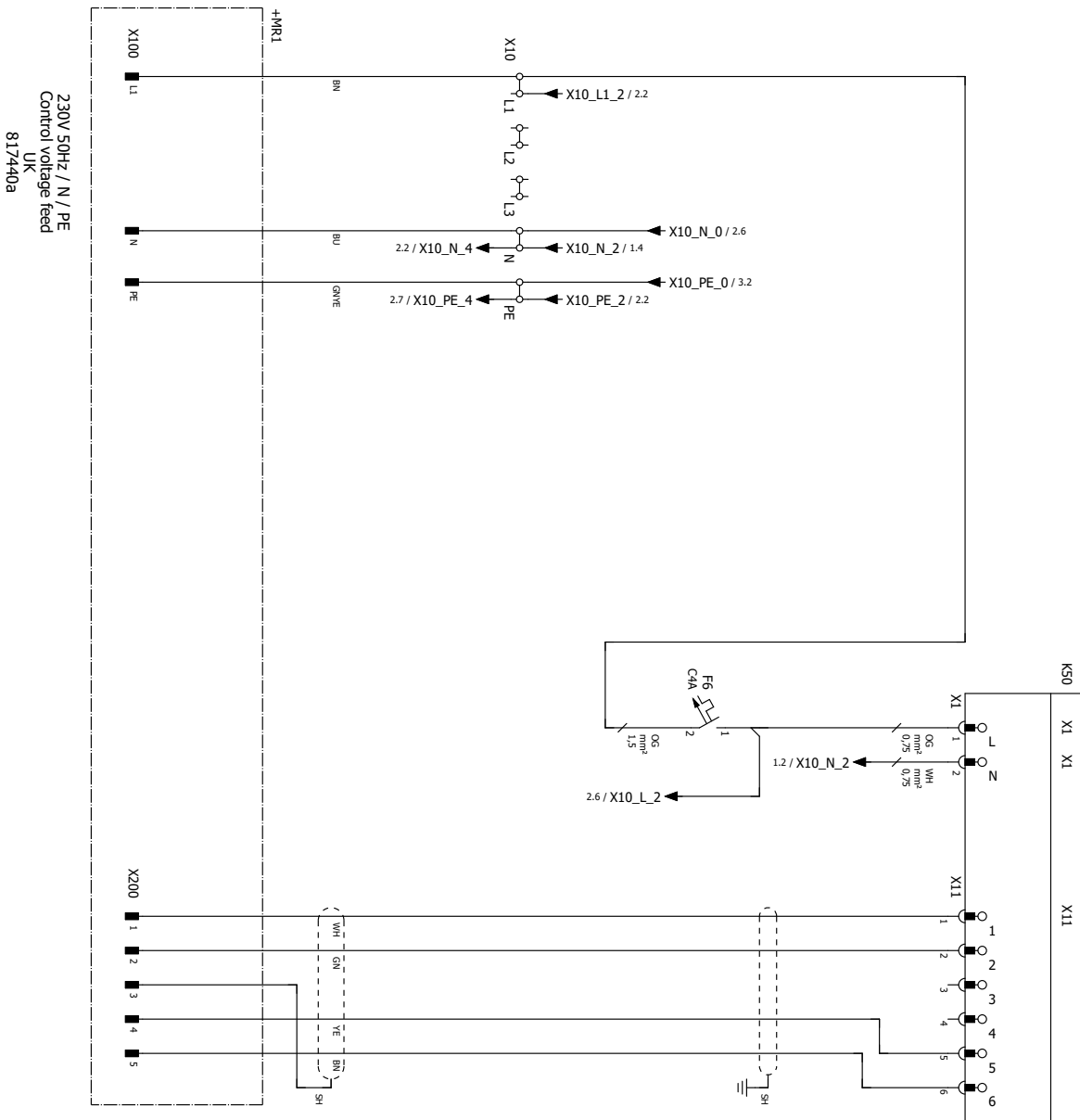

0
1
2
3
4
5
6
7
8
9

Refer to protection notice ISO 16016.



Circuit diagram 2/5

LWCV 82R1/3 Heat pump module

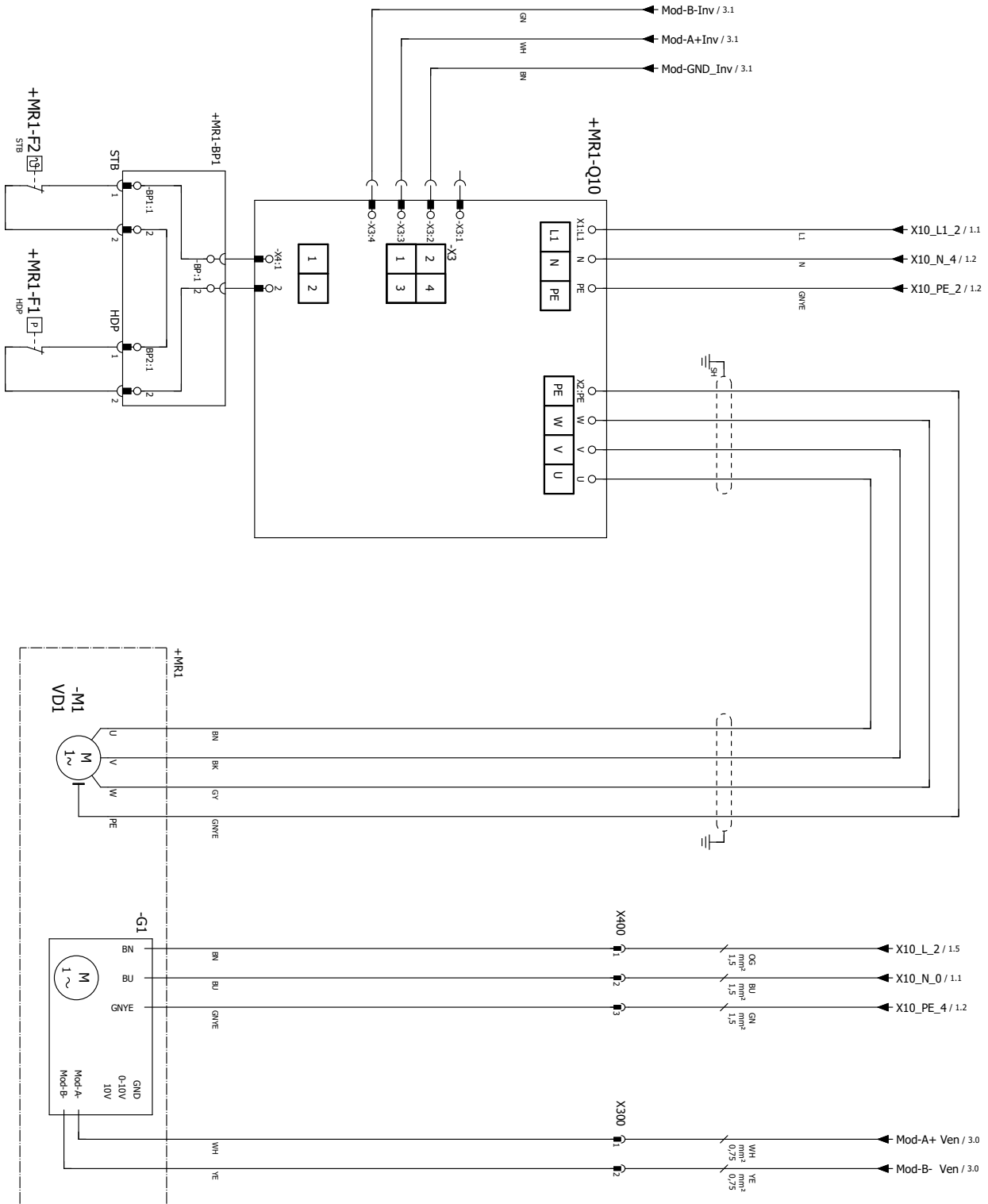

Refer to protection notice ISO 16016.



LWCV 82R1/3 Heat pump module

Circuit diagram 3/5

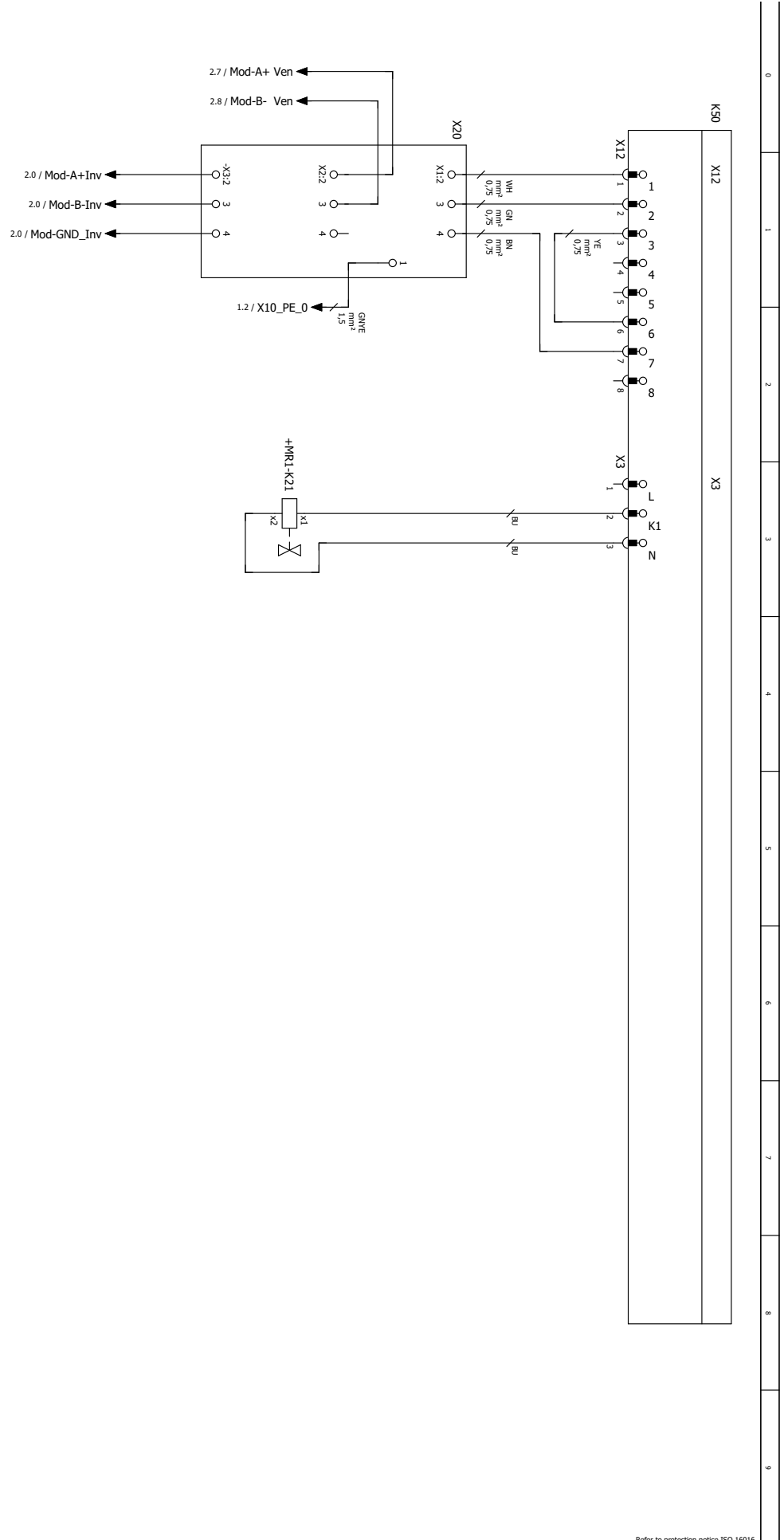

Refer to protection notice ISO 16016.



Circuit diagram 4/5

LWCV 82R1/3 Heat pump module

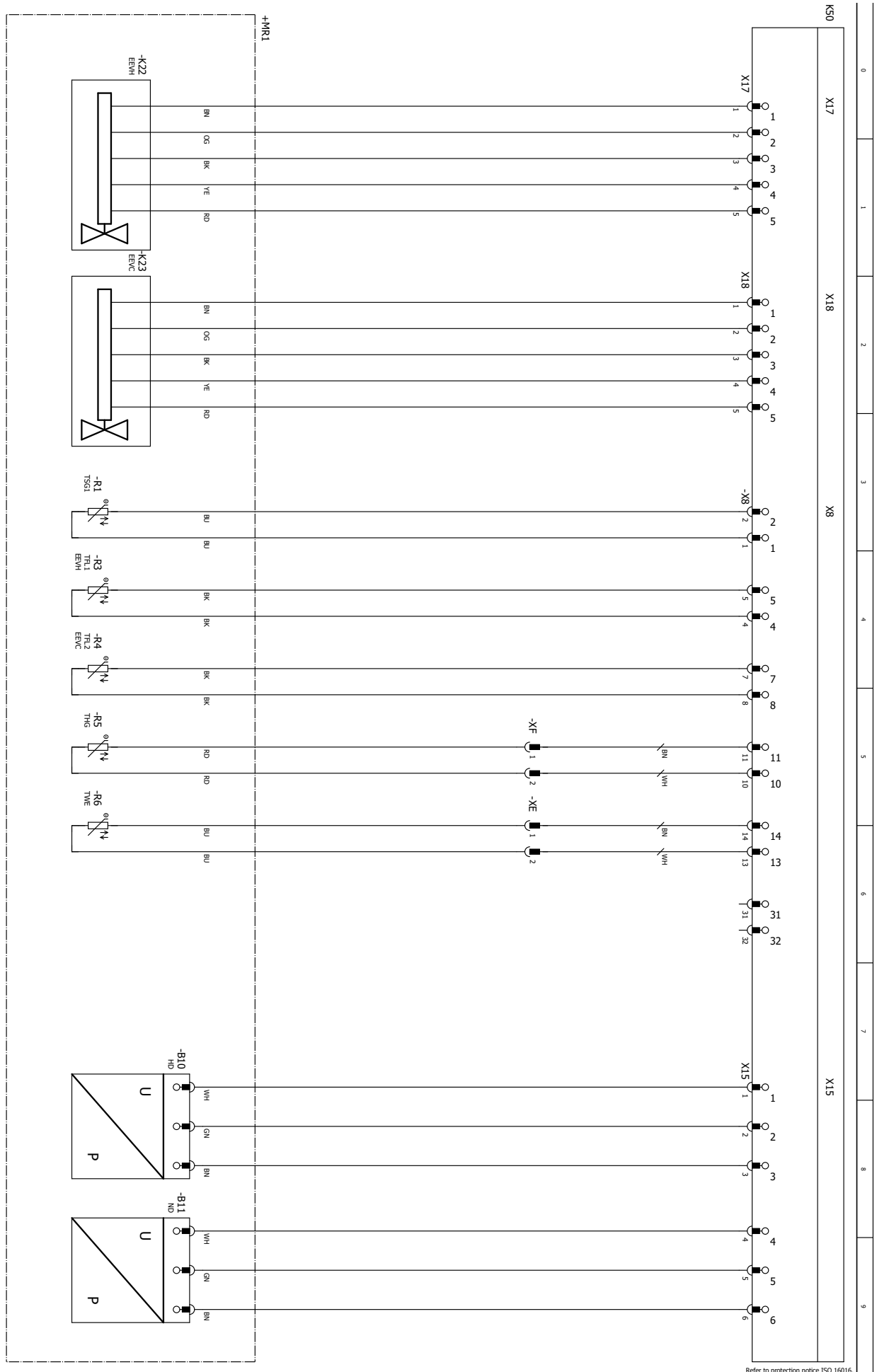

Refer to protection notice ISO 16016.



LWCV 82R1/3 Heat pump module

Circuit diagram 5/5

Equipment	Description
B2	Volumetric flow meter
B10	High-pressure sensor
B11	Low pressure sensor
E20	Compressor heating
F1	High-pressure switch
F2	Temperature switch
F6	Fuses ventilator
G1	Fan
K21	Defrost valve
K22	Electronic expansion valve heating
K23	Electronic expansion valve cooling
K50	ASB board
M1	Compressor
Q10	Inverter
R1	Suction sensor, condenser
R3	Liquid temperature heating
R4	Liquid temperature cooling
R5	Hot gas sensor
R6	Heat source input sensor
RF1	Mains filter
X10	Distribution box power supply output compressor
X20	MODBUS circuit board
X200	Control connector
XSH	Shield clamp Control unit
XE / XF	Plug connector
+MR1	Machine room

Refer to protection notice ISO 16016.



Circuit diagram 1/5

LWCV 122R3 Heat pump module

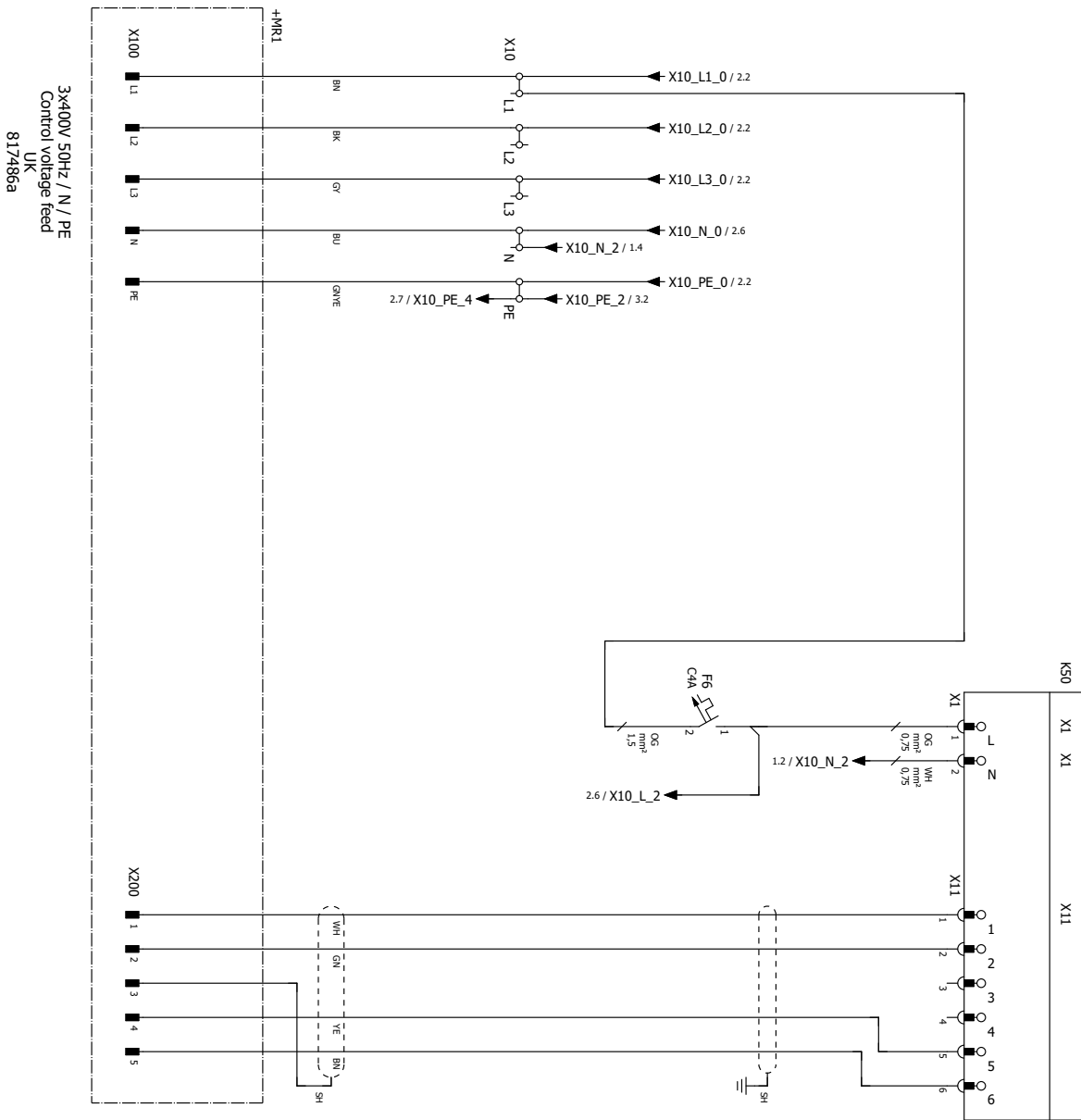

0	1	2	3	4	5	6	7	8	9
---	---	---	---	---	---	---	---	---	---

Refer to protection notice ISO 16016.



LWCV 122R3 Heat pump module

Circuit diagram 2/5

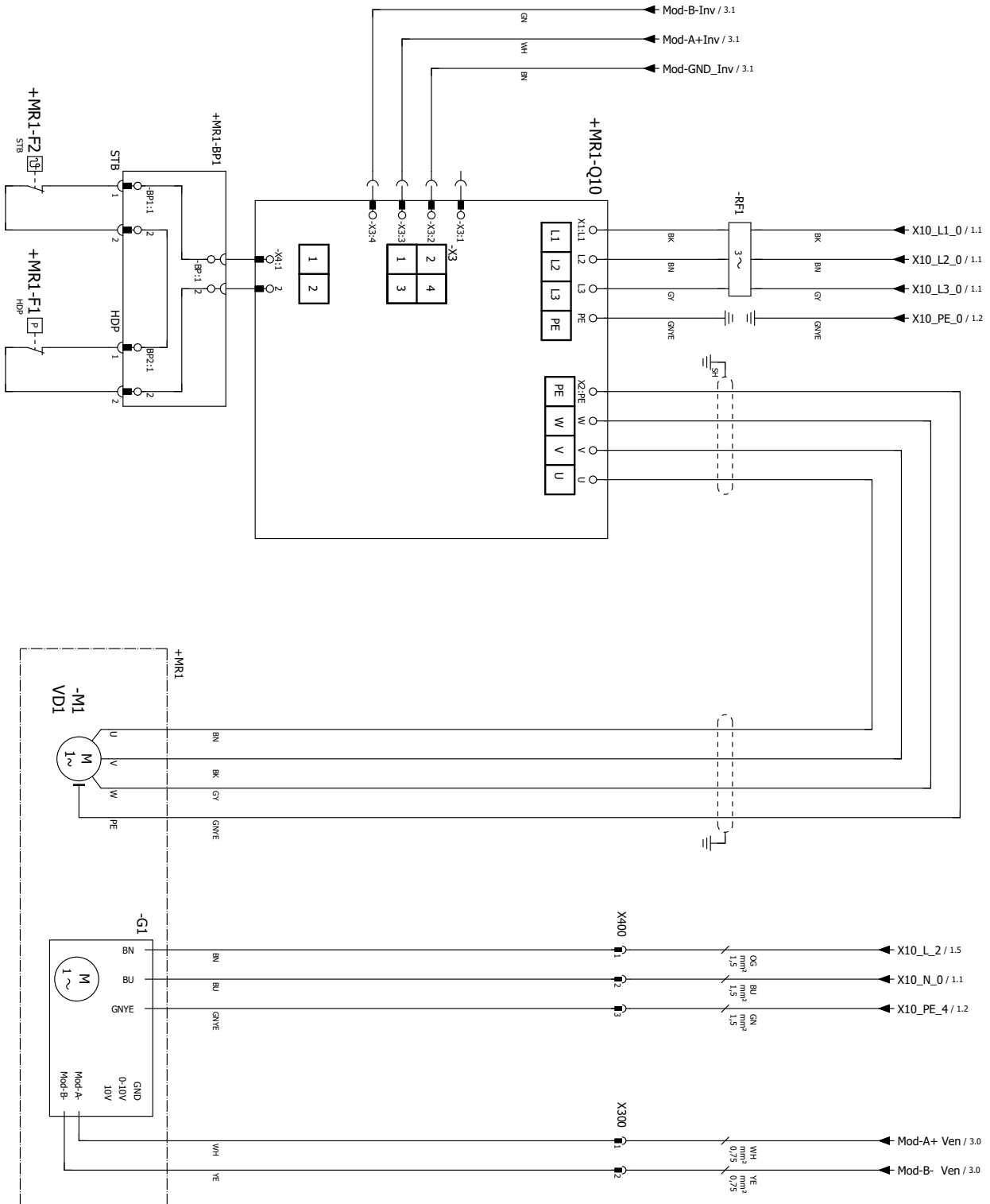

Refer to protection notice ISO 16016.



Circuit diagram 3/5

LWCV 122R3 Heat pump module

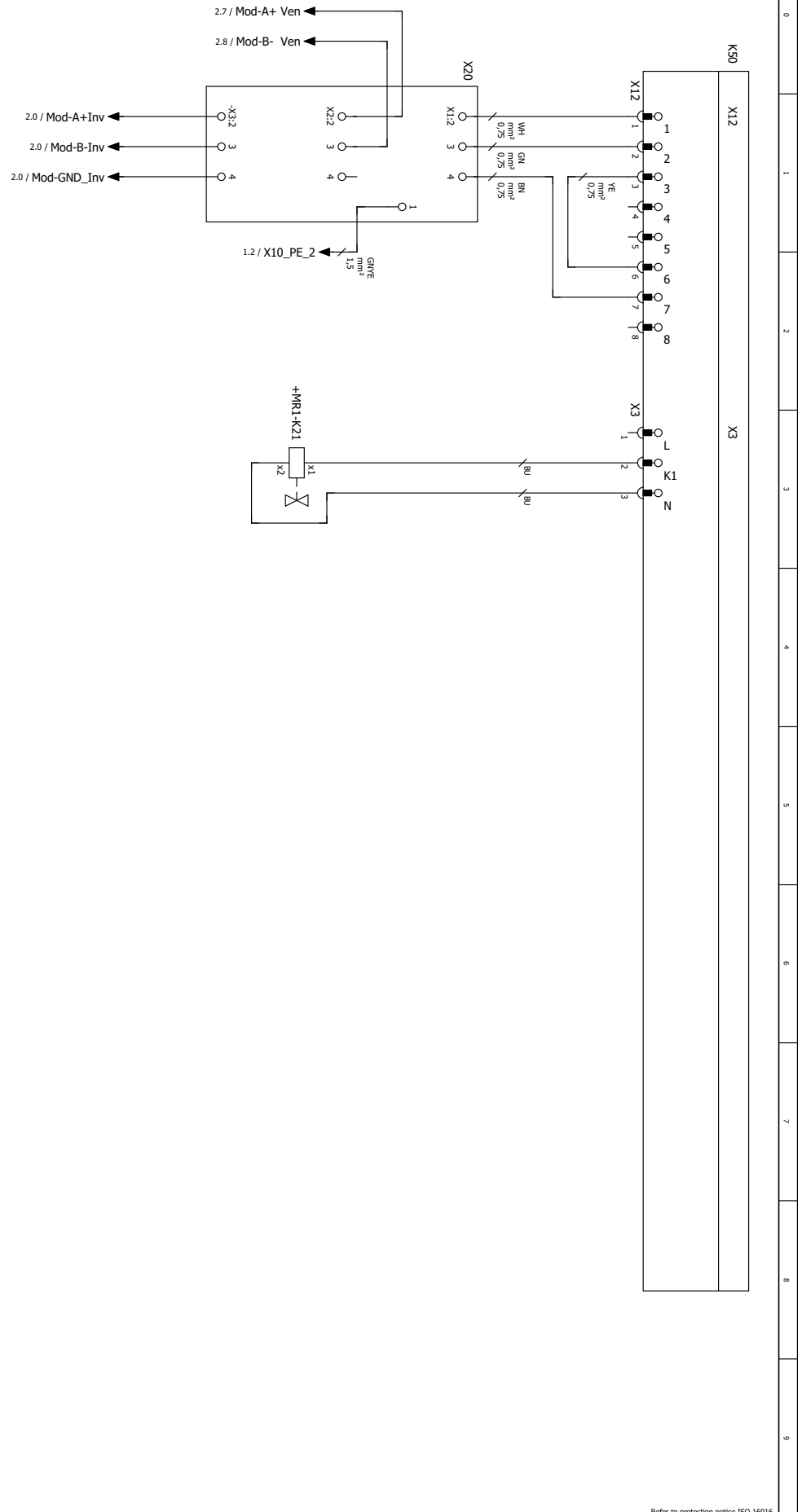



LWCV 122R3 Heat pump module

Circuit diagram 4/5

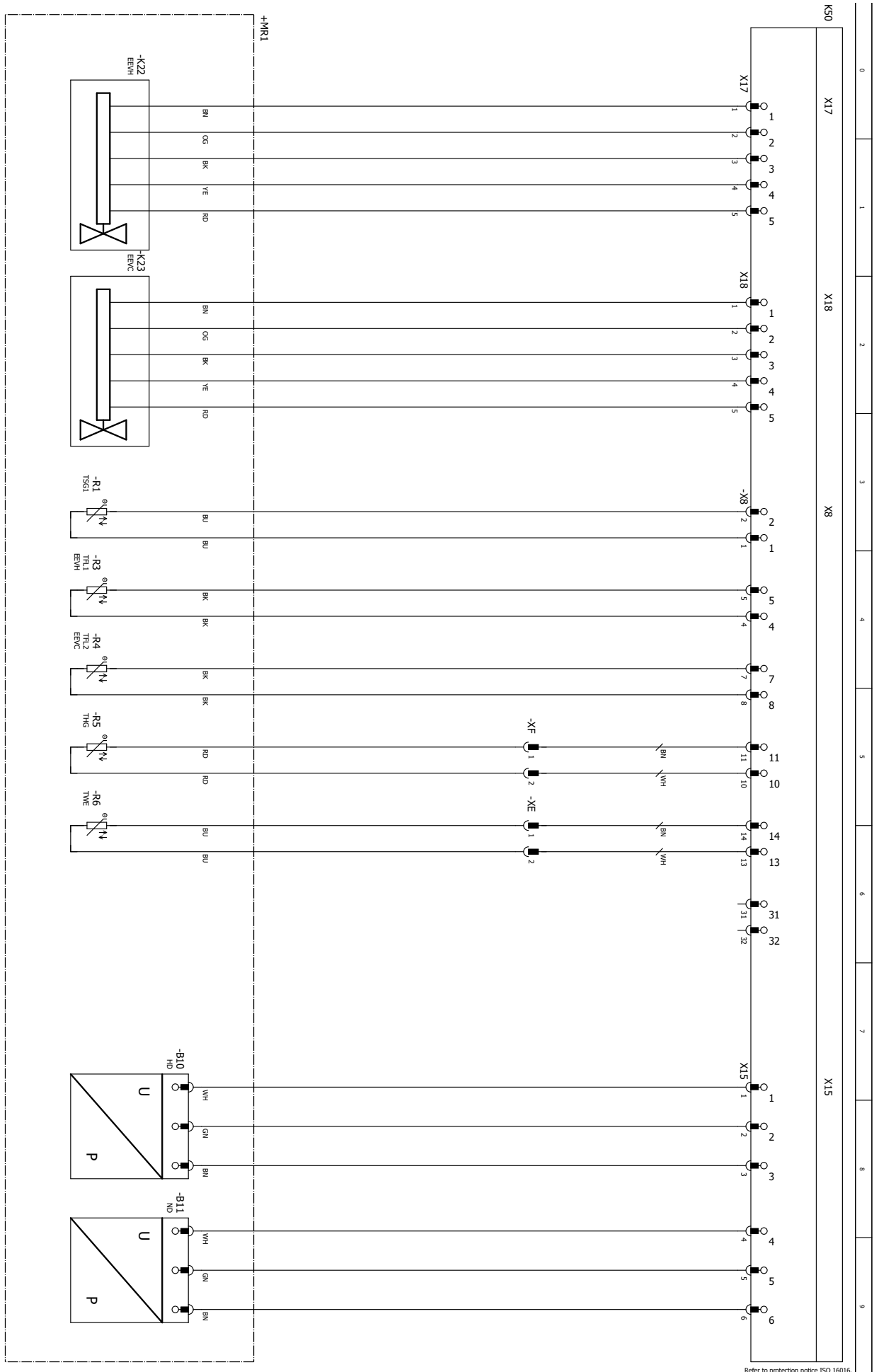

Refer to protection notice ISO 16016.



Circuit diagram 5/5

LWCV 122R3 Heat pump module

Equipment	Description
B2	Volumetric flow meter
B10	High-pressure sensor
B11	Low pressure sensor
E20	Compressor heating
F1	High-pressure switch
F2	Temperature switch
F6	Fuses ventilator
G1	Fan
K21	Defrost valve
K22	Electronic expansion valve heating
K23	Electronic expansion valve cooling
K50	ASB board
M1	Compressor
Q10	Inverter
R1	Suction sensor, condenser
R3	Liquid temperature heating
R4	Liquid temperature cooling
R5	Hot gas sensor
R6	Heat source input sensor
RF1	Mains filter
X10	Distribution box power supply output compressor
X20	MODBUS circuit board
X200	Control connector
XSH	Shield clamp Control unit
XE / XF	Plug connector
+MRI	Machine room

Refer to protection notice ISO 16016.









alpha innotec

ait-deutschland GmbH
Industriestraße 3
95359 Kasendorf
Germany

T • +49 9228 / 9906-0
F • +49 9228 / 9906-189
E • info@alpha-innotec.de

www.alpha-innotec.com

alpha innotec – an ait-deutschland GmbH brand

Subject to technical amendments without prior notice.