

# OPERATING MANUAL LWV - SERIES

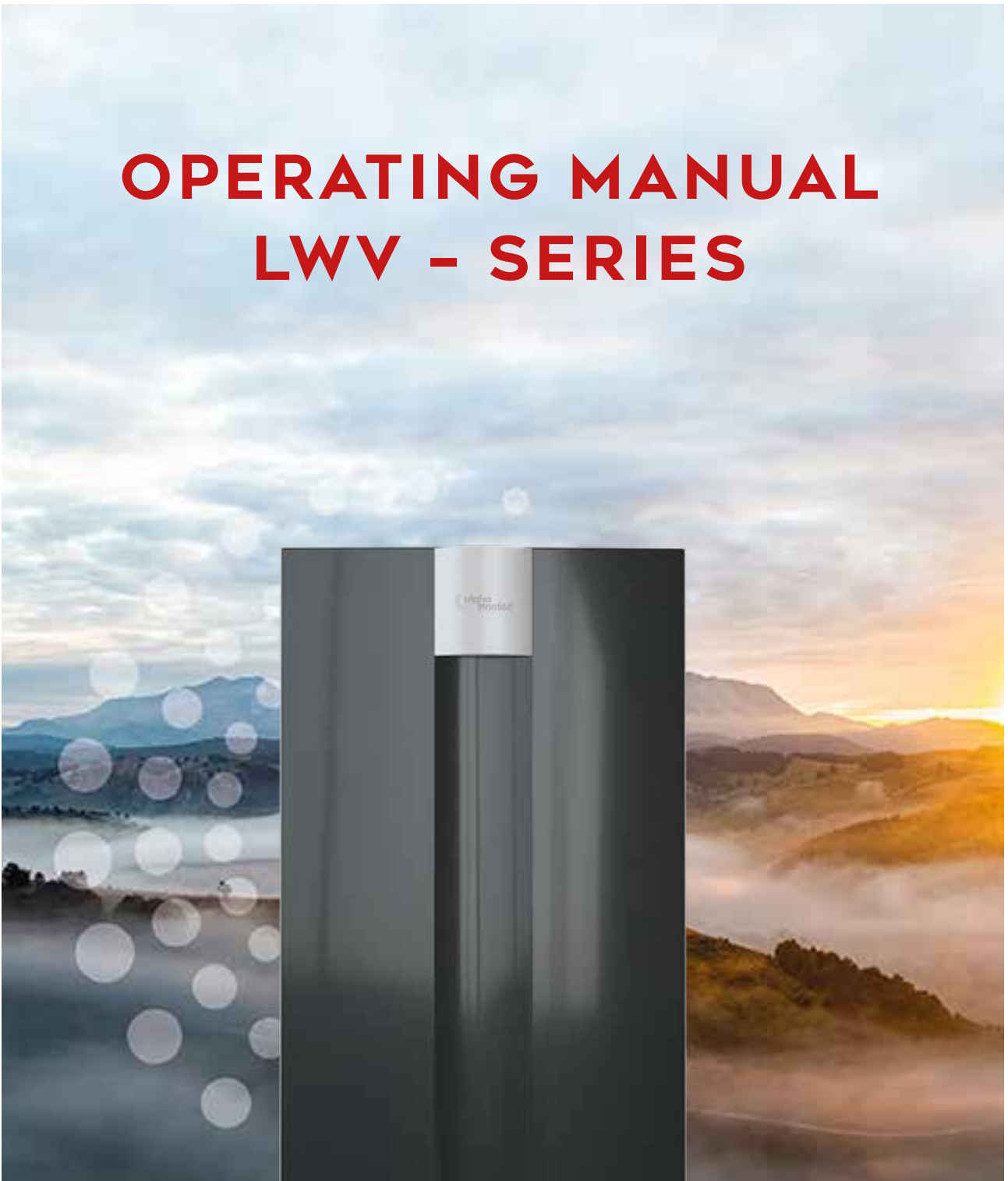

83059100kUK

## UK

Air/Water heat pumps  
Indoor installation



## Table of contents

1	About this operating manual	3	12	Maintenance	20
1.1	Validity	3	12.1	Basic principles	20
1.2	Reference documents	3	12.2	Maintenance after commissioning	20
1.3	Symbols and markings	3	12.3	Maintenance as required	20
1.4	Contact	4	12.4	Clean and flush condenser	21
2	Safety	4	12.5	Yearly maintenance	21
2.1	Intended use	4	13	Faults	21
2.2	Personnel qualifications	4	14	Dismantling and disposal	21
2.3	Personal protective equipment	4	14.1	Dismantling	21
2.4	Residual risks	5	14.2	Disposal and recycling	21
2.5	Disposal	5	Technical data / Scope of supply	22	
2.6	Avoid damage to property	5	Performance curves	23	
3	Description	6	LWV 82R1/3	23	
3.1	Delivery condition	6	LWV 122R3	25	
3.2	Layout	6	Dimensional drawings	27	
3.3	Accessories	7	Installation plans	29	
3.4	Function	7	Coastal installation	37	
4	Operation and care	8	Hydraulic integration	38	
4.1	Energy-conscious and environmentally-aware operation	8	LWV with hydraulic station	38	
4.2	Care	8	LWV with buffer tank in series and hydraulic module	39	
5	Delivery, storage, transport and installation	8	LWV with separation tank	40	
5.1	Scope of supply	8	Keys hydraulic integration	41	
5.2	Storage	9	Circuit diagrams	42	
5.3	Unpacking and transport	9	LWV 82R1/3	42	
5.4	Installation	10	LWV 122R3	47	
5.5	Installation of air ducting	12			
5.6	Attach side walls, rear wall and cover	12			
6	Installation of hydraulic system	12			
7	Electrical installation	13			
8	Flushing, filling and venting	17			
8.1	Heating water quality	17			
8.2	Flush, fill and vent the heating circuit	18			
9	Insulate hydraulic connections	18			
10	Set the overflow valve	18			
11	Commissioning	19			



# 1 About this operating manual

This operating manual is part of the unit.

- ▶ Before working on or with the unit read the operating manual carefully and follow it for all activities at all times, especially the warnings and safety instructions.
- ▶ Keep the operating manual to hand at the unit and hand over to the new owner if the unit changes hands.
- ▶ If you have any questions or anything is unclear, ask the local partner of the manufacturer or the factory's customer service.
- ▶ Note and follow all reference documents.

## 1.1 Validity

This operating manual refers solely to the unit identified by the nameplate (→ "Nameplates", page 7).

## 1.2 Reference documents

The following documents contain additional information to this operating manual:

- Planning & design manual, hydraulic integration
- Operating manual of the hydraulic unit or the wall-mounted controller
- Operating manual of the heating and heat pump controller
- Brief description of the heat pump controller
- Operating manual of the expansion board (accessories)
- Log book

## 1.3 Symbols and markings

### Identification of warnings

Symbol	Meaning
	Safety-relevant information. Warning of physical injuries.
	Safety-relevant information. Warning of physical injuries. Flammable materials / flammable (primary) refrigerant
	Safety-relevant information. Warning of physical injuries. Flammable materials / flammable (primary) refrigerant

Symbol	Meaning
	Safety-relevant information. Warning of physical injuries. Danger of fatal injury due to electric current.
<b>DANGER</b>	Indicates an imminent danger resulting in severe injuries or death.
<b>WARNING</b>	Indicates a potentially dangerous situation, which can result in severe injuries or death.
<b>CAUTION</b>	Indicates a potentially dangerous situation, which can result in moderate or minor injuries.
<b>IMPORTANT</b>	Indicates a potentially dangerous situation, which can result in material damage.

### Symbols in the document

Symbol	Meaning
	Information for specialist
	Information for operator
✓	Prerequisite for an action
▶	Procedural instructions: Single-step instruction for action
1., 2., 3., ...	Procedural instructions: Numbered step within a multi-step instruction for action. Adhere to the given sequence.
	Additional information, e.g. a note for making work easier, information on standards
→	Reference to further information elsewhere in the operating manual or in another document
•	List
	Secure connections against twisting



## 1.4 Contact

Addresses for purchasing accessories, for service cases or for answers to questions about the unit and this operating manual can be found on the internet and are kept up-to-date:

- [www.alpha-innotec.com](http://www.alpha-innotec.com)

## 2 Safety

Only use the unit if it is in proper technical condition and only use it as intended, safely and aware of the hazards, and follow this operating manual.

### 2.1 Intended use

The unit is designed for household use and is solely intended for the following functions:

- Heating
- Domestic hot water preparation (optional, with accessories)
- Cooling, reversible
- ▶ Proper use includes complying with the operating conditions (→ “Technical data / Scope of supply”, page 22) and the operating manual and noting and following the reference documents.
- ▶ When using the local regulations note: laws, standards, guidelines, directives.

All other uses of the unit are not as intended.

### 2.2 Personnel qualifications

The operating manuals supplied with the product are intended for all users of the product.

The operation of the product via the heating and heat pump control and work on the product which is intended for end customers / operators is suitable for all age groups of persons who are able to understand the activities and the resulting consequences and can carry out the necessary activities.

Children and adults who are not experienced in handling the product and do not understand the necessary activities and the resulting consequences must be instructed and, if necessary, supervised by persons experienced in handling the product and who are responsible for safety.

Children must not play with the product.

The product may only be opened by qualified personnel.

All procedural instructions in this operating manual are intended exclusively for qualified and skilled personnel.

Only qualified, skilled personnel is able to carry out the work on the unit safely and correctly. Interference by unqualified personnel can cause life-threatening injuries and damage to property.

- ▶ Ensure that the personnel are familiar with the local regulations, especially those relating to working safely and in awareness of the hazard risks.
- ▶ Ensure that the personnel are qualified to handle refrigerant.
- Work on the refrigerating circuit may only be carried out by qualified personnel with appropriate qualifications for refrigeration system installation.
- Work on the electrics and electronics may only be carried out by electrical technicians.
- Any other work on the system may only be carried out by qualified personnel (heating installer, plumbing installer).

During the warranty and guarantee period, service work and repairs may only be carried out by personnel authorised by the manufacturer.

### 2.3 Personal protective equipment

During transport and work on the unit, there is a risk of cuts due to the sharp edges of the unit.

- ▶ Wear cut-resistant protective gloves.

During transport and work on the unit, there is a risk of foot injuries.

- ▶ Wear safety shoes.

When working on liquid-conveying lines, there is a risk of injury to the eyes due to leakage of liquids.

- ▶ Wear safety goggles.



## 2.4 Residual risks

### Electric shock

Components in the unit are live with life-threatening voltage. Before opening the unit panelling:

- ▶ Disconnect unit from power supply.
- ▶ Protect unit against being switched back on again.
- ▶ Residual voltage at the inverter. Wait 90 seconds before opening the device.

Existing earthing connections within housings or on mounting plates must not be altered. If this should nevertheless be necessary in the course of repair or assembly work:

- ▶ Restore earthing connections to their original condition after completion of the work.

### Injury due to moving parts

- ▶ Switch device on only with air ducts and weather and/or rain protection grid fitted.

### Injuries caused by high temperatures

- ▶ Before working on the unit, let it cool down.

### Safety instructions and warning symbols

- ▶ Observe the safety instructions and warning symbols on the packaging and on and in the unit.

### Injuries and environmental damage due to refrigerant

The unit contains harmful and environmentally dangerous refrigerant. If refrigerant leaks from the unit:

1. Switch off unit.
2. Thoroughly ventilate installation area.
3. Notify authorised after sales service.

## 2.5 Disposal

### Environmentally hazardous substances

Improper disposal of environmentally hazardous substances (e.g. refrigerant, compressor oil) damages the environment:

- ▶ Collect substances safely.
- ▶ Dispose of the substances in an environmentally-friendly manner according to the local regulations.

## 2.6 Avoid damage to property

The ambient air at the heat pump installation site, as well as the air drawn in as a heat source, must not contain any corrosive constituents!

Constituents such as

- Ammonia
- Sulphur
- Chlorine
- Salt
- Sewer gasses, flue gasses

can cause damage to the heat pump, which could lead to the complete failure / destruction of the heat pump!

### Cooling

If the heating surfaces are used for heating and cooling, the control valves must be suitable for heating and cooling.

By cooling with low flow temperatures, condensate can be expected to form on the heat distribution system as the temperature falls below the dew point. If the heat distribution system is not designed for these operating conditions, it must be protected by appropriate safety devices, e.g. dew point monitor (purchasable accessory).

### Decommissioning / draining the heating

If the system / heat pump is decommissioned or emptied, after it has been filled already, it is necessary to ensure that the condenser and any heat exchangers present have been completely emptied in the event of frost. Residual water in heat exchangers and condensers can result in damage to components.

- ▶ Empty system and condenser completely, open vent valves.
- ▶ Blast out with compressed air if necessary.

### Improper action

Requirements for minimum scale and corrosion damage in hot water heating systems:

- Proper planning, design and commissioning
- Closed system with regard to corrosion
- Integration of an adequately dimensioned pressure maintaining device
- Use of demineralised heating water (VE water) or water corresponding to the VDI 2035 norm



- Regular servicing and maintenance

If a system is not planned, designed, started up and operated in accordance with the given requirements, there is a risk that the following damage and faults will occur:

- Malfunctions and the failure of components, e.g. pumps, valves
  - Internal and external leaks, e.g. from heat exchangers
  - Cross-section reduction and blockages in components, e.g. heat exchanger, pipes, pumps
  - Material fatigue
  - Gas bubbles and gas cushion formation (cavitation)
  - Negative effect on heat transfer, e.g. formation of coatings, deposits, and associated noises, e.g. boiling noises, flow noises
- Note and follow the information in this operating manual for all work on and with the unit.

### Unsuitable quality of the fill and make-up water in the heating circuit

The efficiency of the system and the life of the heat generator and the heating components depend decisively on the quality of the heating water.

If the system is filled with untreated drinking water, calcium and magnesium precipitate as mineral scale. Limescale deposits form on the heat transfer surfaces of the heating. The efficiency drops and energy costs rise. In extreme cases the heat exchangers are damaged.

- Fill the system with deionised heating water (VE water) or with water corresponding to the VDI 2035 norm only (low-salt operation of the system).

## 3 Description

### 3.1 Delivery condition

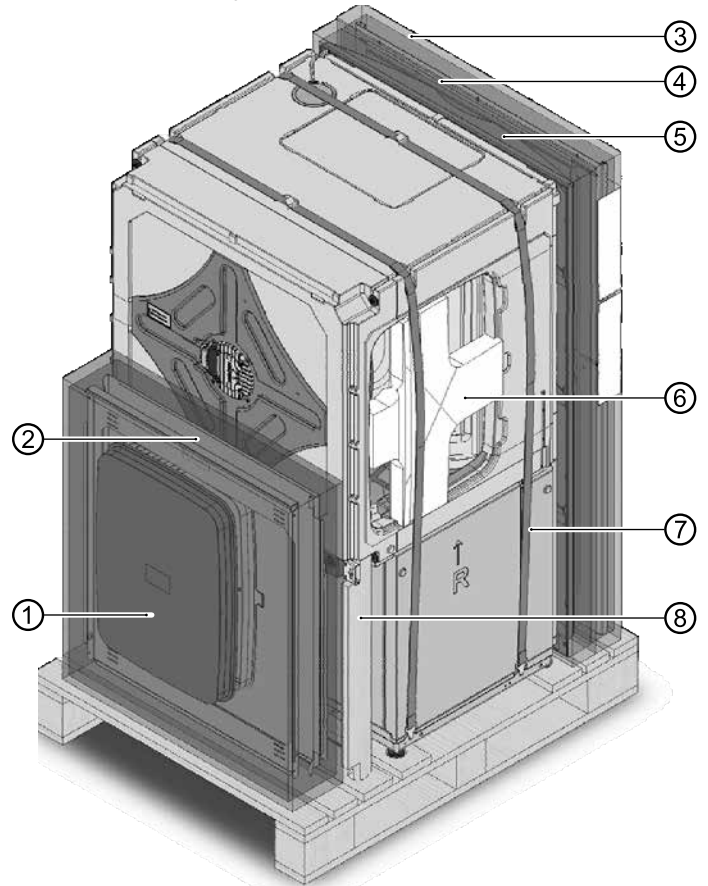

- 1 Blind cover and louvre grille
- 2 Side wall (2-piece) and cover
- 3 Rear wall
- 4 Side wall (complete)
- 5 Front wall
- 6 Supporting crosspiece (left and right; only remove after positioning at the final installation site!)
- 7 Lashing straps (with grip openings)
- 8 Wooden strip / fan support

### 3.2 Layout



#### NOTE

This section essentially names the components relevant for fulfilling the tasks described in this operating manual.



## The heat pump module

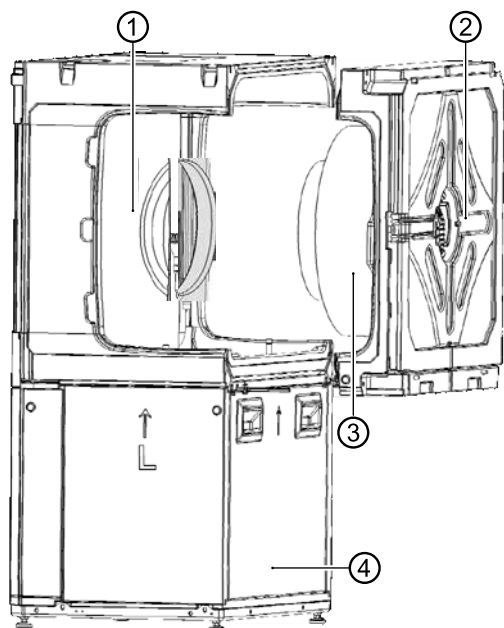

- 1 Evaporator module
- 2 Fan module
- 3 Fan
- 4 Refrigerant circuit module

## The refrigerant circuit module

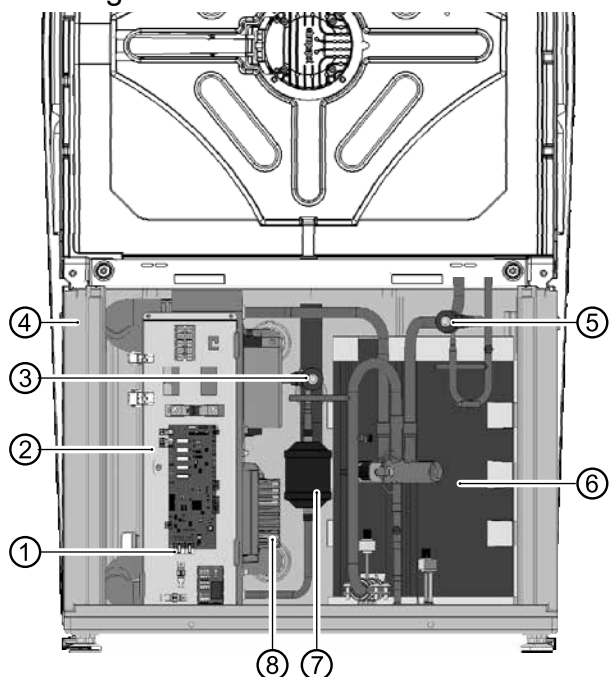

- 1 Plug connection to the fan module
- 2 Electrical switch box
- 3 Expansion valve (cooling, defrost)
- 4 Condenser
- 5 Expansion valve (heating)
- 6 Compressor (in the insulated housing)
- 7 Filter dryer
- 8 Inverter unit

## Nameplates

One nameplate is attached to the heat pump module in the rear facade cut-out at the factory.

Two further nameplates are included in the delivery.

- ▶ Stick one nameplate on the outside of the unit on the lower facade of the switch box side.
- ▶ Glue one nameplate into the logbook for heat pumps.

The nameplates contain the following information at the very top:

- Model, item number
- Serial number

The nameplates also contain an overview of the most important technical data.

## 3.3 Accessories

The following accessories are available for the unit through the manufacturer's local partner:

- Electrical connection kit
- Air / magnetic sludge separator
- Domestic hot water tank
- Buffer tank
- Room thermostat to switch the cooling function
- Dew point monitor to protect a system with cooling function at low flow temperatures
- Room control panel to control the main functions from the living room

## 3.4 Function

Liquid refrigerant is evaporated (evaporator), the energy for this process is environmental heat and comes from the outside air. The gaseous refrigerant is compressed (compressor), this causes the pressure to rise and therefore the temperature too. The gaseous refrigerant at a high temperature is liquefied (condenser).

The high temperature is hereby discharged to the heating water and is used in the heating circuit. The liquid refrigerant at a high pressure and high temperature is depressurised (expansion valve). The pressure and temperature drop and the process begins again.

The heated heating water can be used for the domestic hot water charging or for the building heating. The temperatures required and use are controlled by the heat pump controller. Reheating, drying out screed or increasing the domestic hot water temperature can be carried out using an electric heating element, which is activated by the heat pump controller as and when necessary.



The integrated vibration decouplers for the hydraulics prevent structure-borne sound and vibrations from being transferred into the fixed pipes and therefore into the building.

## Cooling

Cooling is integrated in the units. The following options are possible for units with cooling function (→ operating manual of the heating and heat pump controller):

- Active cooling  
Cooling down to a minimum flow temperature of 18°C possible in combination with hydraulic module or hydraulic station. Possible to 7°C in conjunction with wall-mounted controller
- Cooling below 18 °C is only possible in the case of hydraulic integration with separation buffer tank
- Control of the cooling function via the heating and heat pump controller
- Changeover between heating and cooling operation

## Network connection on the control panel

The control panel can be connected to a computer or network via a network cable. The heating and heat pump controller can then be controlled from the computer or from the network. Furthermore, the manufacturer's internet-based service can also be used.

## 4 Operation and care



### NOTE

The unit is operated via the control panel of the heating and heat pump controller (→ operating manual of the heating and heat pump controller).

### 4.1 Energy-conscious and environmentally-aware operation

The generally accepted requirements for an energy-conscious and environmentally-aware operation of a heating system also apply when using a heat pump. The most important measures include:

- No unnecessarily high flow temperature
- No unnecessarily high domestic hot water temperature
- Do not open windows with gap / tilt open (continuous ventilation), but instead open wide for a short time (shock ventilation).
- Make sure that the controller settings are correct.

## 4.2 Care

Wipe down the outside of the unit only using a damp cloth or cloth with mild cleaning agent (washing-up liquid, neutral cleaning agent). Do not use any harsh, abrasive, acid or chlorine-based cleaning agents.

## 5 Delivery, storage, transport and installation

### IMPORTANT

Damage to the housing and the unit components due to heavy objects.

- ▶ Do not place any objects on the unit.

### 5.1 Scope of supply

- ▶ Check delivery immediately after receipt for externally visible damage and completeness.
- ▶ Notify supplier of any defects immediately.

The accompanying parts package contains

#### Package 1

- 3 flat seals 5/4"
- 4 flat seals 1"

#### Package 2

- 1 tube lubricant
- 1 HT-bend DN 40mm 87°
- 1 protective cover for plug
- 4 EPP screws

#### In façade package

- 2 screws M5x16, black for the front wall
- 15 screws for façade mounting M5x9
- 1 plastic louvre grille
- 1 heat pump blind cover
- Swelling tape for louvre grille and blind cover
- Documents (manuals, ERP data and label)
- Type sticker





## 5.2 Storage

- ▶ Do not unpack the unit until directly before installation if possible.
- ▶ Store unit protected against
  - Moisture/damp
  - Frost
  - Dust and dirt

## 5.3 Unpacking and transport

### Notes on safe transport

The unit is heavy (→ “Technical data / Scope of supply”, page 22). There is a risk of injuries or damage to property if the unit falls or overturns.

The hydraulic connections are not designed for mechanical loads.

- ▶ Do not lift or transport the unit by the hydraulic connections.

Transport the unit preferably with a pallet truck, alternatively with a handcart or by carrying

- ▶ Do not tilt the heat pump module by more than 45°.
- ▶ The lashing straps on the heat pump module may only be used when carrying by hand.

### Transport with a pallet truck

- ▶ Transport the unit to the place of installation packaged and secured on a wooden pallet.

### Unpacking

1. Remove plastic films. Ensure that you do not damage the unit.
2. Dispose of the transport and packaging material in an environmentally friendly way and in accordance with local regulations.
3. Remove the film from the plastic element of the front panel in the place of installation.

Lift the housing walls off the pallet and set down.

If the unit is not transported by a pallet truck: do not lift off the pallet until after unpacking and setting down the housing panels.

- The façade front is located in front of the device
- The single-part and two-part side wall are located on the rear side

### Optional disconnection of the fan module



#### NOTE

The fan module can be removed if required (narrow passages).

1. Disconnect the plug-in connection of the load and bus cable at the top left on the refrigerant circuit switch box.
2. Remove the 4 screws.
3. Remove the fan module and set it down safely.
4. Break off the projecting struts on the supporting crosspieces.

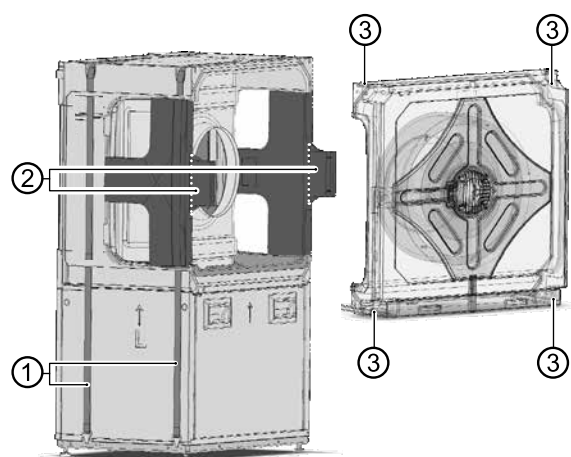

- 1 Lashing straps with grip openings
- 2 Styrofoam struts
- 3 Screws on the fan module

### Disconnecting the evaporator module



#### NOTE

The evaporator module can be disconnected from the refrigerant circuit module if required. This work must be carried out by the factory customer service department!

- ▶ Please contact the factory customer service department.



## Carrying the unit and transporting with a handcart

- ✓ Housing walls are set down.

There are two lashing straps around the heat pump module with grip openings at different heights. These can be used for lifting and carrying.

To provide additional stability, two supporting cross-pieces are clamped in the side cut-outs for the air ducts. Do not remove these until transport is complete!

## Transporting the heat pump module with a handcart

1. Only place the heat pump module onto the handcart with the narrow side, left or right.

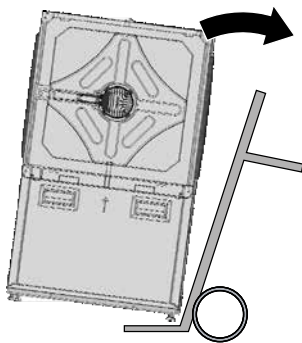

2. Secure the heat pump module to the handcart with lashing straps.



3. Transport the heat pump module to the installation site.

## 5.4 Installation



### CAUTION

In the air outlet area the air temperature is approx. 5 K below the ambient temperature. Under certain climatic conditions, an ice layer can therefore form in the air outlet area. Install the heat pump such that the air blower does not discharge into footpath areas.

## Installation room and space requirements



### NOTE

Note and follow the local regulations and standards regarding the installation room and space requirements. The table shows the regulations according to EN 378-1 relevant in Germany.

Refrigerant	Limit value [kg/m <sup>3</sup> ]
R 134a	0.25
R 404A	0.52
R 407C	0.31
R 410A	0.44
R 448A	0.39
R 454B	0.358

→ “Technical data / Scope of supply”, page 22

$$\text{Minimum room volume} = \frac{\text{Refrigerant capacity [kg]}}{\text{Limit value [kg/m}^3\text{]}}$$



### NOTE

If several heat pumps of the same type are installed, only one heat pump need to be taken into account. If several heat pumps of different types are installed, only the heat pump with the largest refrigerant volume needs to be taken into account.

- ✓ Minimum volume corresponds to the requirements for the refrigerant used.
- ✓ Installation inside the building only.
- ✓ Installation room is dry and frost-free.
- ✓ Clearance dimensions are met (→ “Installation plans”, from page 29).
- ✓ The surface/floor is suitable for installation of the unit:
  - level and horizontal
  - Load-bearing capacity for the unit's weight



### NOTE

The noise emissions of the heat pumps must be taken into account in the respective installation plans for air/water heat pumps. The respective regional regulations must be observed.

### Aligning the unit

1. Align the heat pump module horizontally and stably at the installation site using the height-adjustable feet and a size 13 spanner. Adjustment range: 20 mm. Then fasten with the size 17 lock nuts.

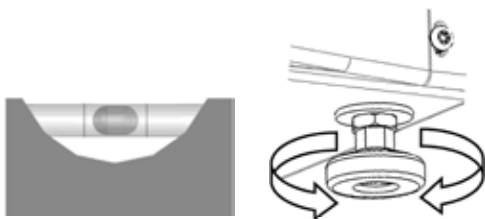

If the fan module has been removed, this must be reinstalled on the evaporator module. Attach the 4 screws (1) and re-establish the two plug-in connections of the load and bus cables.

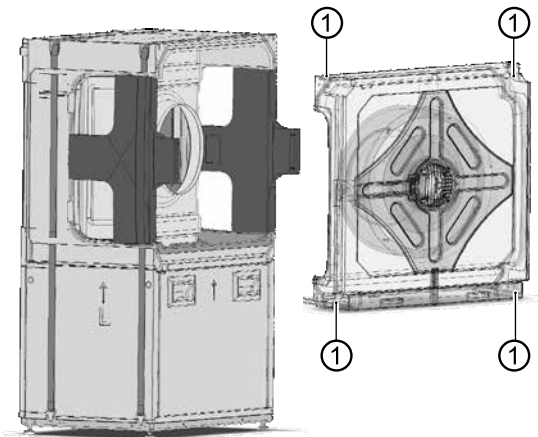

2. Remove the two lashing straps.

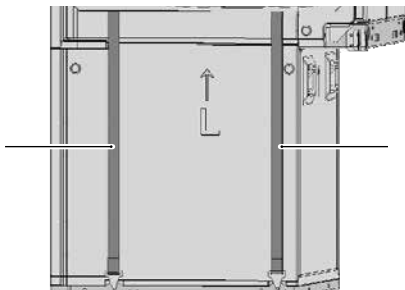

3. Open the strap tensioner and turn the hook on the base plate through 90°.

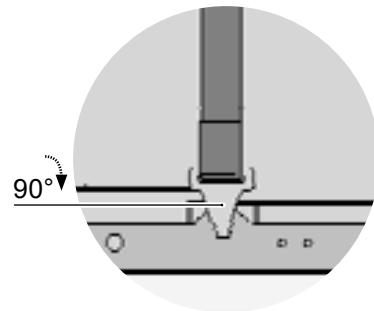

4. Attach the swelling tape to the louvre grille and blind cover by applying it around the edges and then sticking it in place.

→ Heat pump installation instructions

5. Remove the two styrofoam crosspieces.

6. Install the blind cover and the louvre grille.

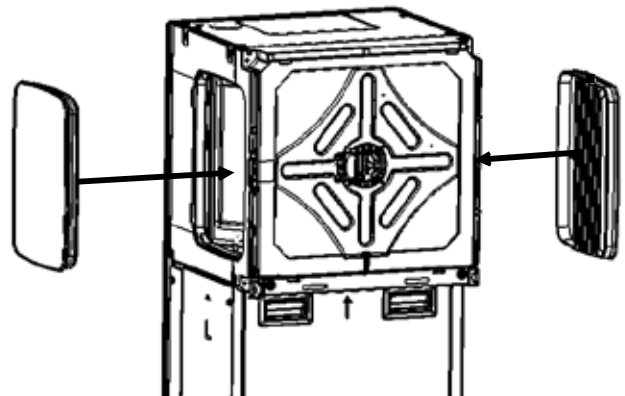

Attach the louvre grille to the air outlet side (right or left)! The blind cover on the opposite side.

7. Attach rear wall and screw firmly into place.

→ Heat pump installation instructions



## 5.5 Installation of air ducting

### Air discharge to right or left

Left air outlet

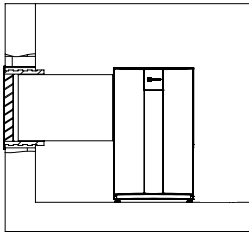

Right air outlet

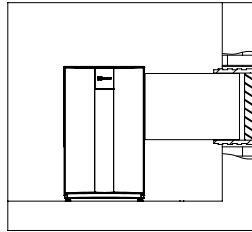

- Air duct installation instructions
- Wall duct installation instructions

### IMPORTANT

The height difference between the vertical centre of the air duct connections on the unit and the top edge of the air inlet / air outlet on the building must not exceed 2 m.

## 5.6 Attach side walls, rear wall and cover

- Heat pump installation instructions
- 1. Fasten rear wall.
- 2. Hang side walls from above. Fasten at the front with a screw in the middle. Fasten with 2 screws at the bottom.
- 3. Fit cover and screw into place.

## 6 Installation of hydraulic system

### IMPORTANT

Avoid open heating systems and / or heating systems that are not oxygen diffusion-tight. If this is not possible, a system separation must be installed.

Depending on the dimensioning of the heat exchanger and the additionally required circulation pump, the system separation worsens the energy efficiency of the system.

### IMPORTANT

Dirt and deposits in the (existing) hydraulic system can cause damage to the heat pump.

- ▶ Ensure that a air / magnetic sludge separator is installed in the heating circuit.
- ▶ Ensure that a dirt filter with a mesh size of 0.7 mm is installed as close as possible to the heating water inlet (return).
- ▶ Rinse the hydraulic system thoroughly prior to establishing the hydraulic connection of the heat pump.



### NOTE

If an existing system is being replaced, the old vibration decoupling may not be reused.

### IMPORTANT

Damage to the copper pipes due to unacceptable loading!

- ▶ Secure all connections against twisting.
- ✓ Cross-sections and lengths of the pipes for the heating circuit are adequately dimensioned.
- ✓ The free pressing of the circulation pumps in the heating circuit at least results in the throughput required for the device type (→ “Technical data / Scope of supply”, page 22).
- ✓ The hydraulic system must be equipped with a buffer tank, the required volume of which depends on your unit model.
- “Technical data / Scope of supply”, page 22
- ✓ The cables for the heating are fixed to the wall or ceiling via a fixed point.

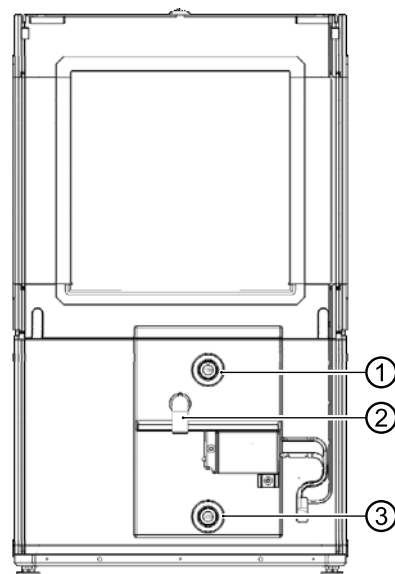

- 1 Heating water supply
- 2 Condensate nozzle
- 3 Heating water return



1. Insert the vent at the highest point of the heating circuit.
2. Ensure that the working overpressures (→ “Technical data / Scope of supply”, page 22) are not exceeded.

### Condensate connection

The outlet for the heating water safety valve and the condensate from the air must be drained off in accordance with the respective applicable standards and regulations. Discharging the condensate and the safety valve outlet into the sewers is only permitted via a funnel waste trap, which must be accessible at all times.

1. Fit an HT-bend onto the condensate outlet.

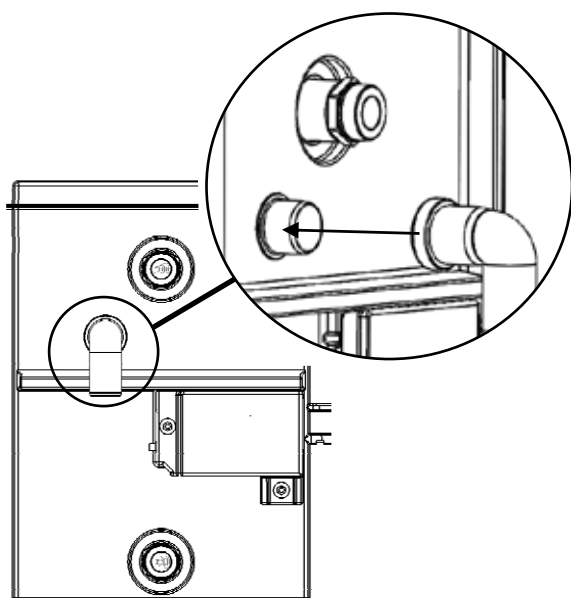

2. Route piping into the funnel waste trap.  
→ Heat pump installation instructions

## 7 Electrical installation

### 7.1 Connect the electrical cables

#### IMPORTANT

Irreparable damage to the compressor due to wrong rotating field (only applies to units with 400V connection).

- ▶ Ensure that there is a clockwise rotary field for the compressor load infeed.

#### Basic information on the electrical connection

- The specifications of the local energy supply company may apply to electrical connections
- Fit the power supply for the heat pump with an all-pole miniature circuit-breaker with at least 3 mm contact spacing (per IEC 60947-2)
- Note the level of the tripping current (→ “Technical data / Scope of supply”, page 22)
- Comply with the electromagnetic compatibility regulations (EMC regulations)
- Lay unshielded power supply cables and shielded cables (bus cable) sufficiently far apart (> 100 mm).

The electrical connection of the heat pump with the hydraulic unit or the wall-mounted controller is established using the EVS8 or EVS accessory.

- EVS 8: sockets and plugs for load and bus cables with 8m cable each.  
A maximum of 3 EVS 8 connections are possible.

→ EVS 8 installation instructions

- EVS: sockets and plugs for load and bus cables.  
Bus cable on site, maximum cable length of 30 m.  
The bus cable must be a shielded cable of at least 4 x 0.5 mm<sup>2</sup>.

As load cable:

- For the 12 kW unit a 5 x 2.5 mm<sup>2</sup> cable with protective conductor, Diameter of the sheath of the electric cable 9 – 13 mm<sup>2</sup>
- For the 8 kW unit a 3 x 2.5 mm<sup>2</sup> cable with protective conductor, Diameter of the sheath of the electric cable 9 – 13 mm<sup>2</sup>



- ▶ Mount the sockets (Ⓑ) towards the heat pump, the plugs (Ⓢ) towards the hydraulic unit or the wall-mounted controller.

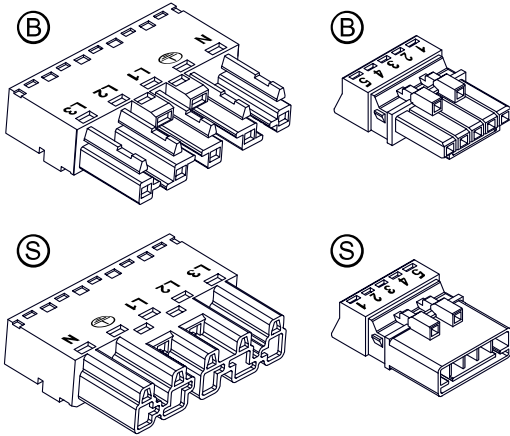

### Mounting EVS 8 / EVS (accessories)

- Connect the compressor load cable to the five-pin load cable socket.
  - Break a lock of one of the cable bushings (①) carefully out of the pre-engaged strain relief housing (②) and push the strain relief housing approx. 50cm over the load cable (③).

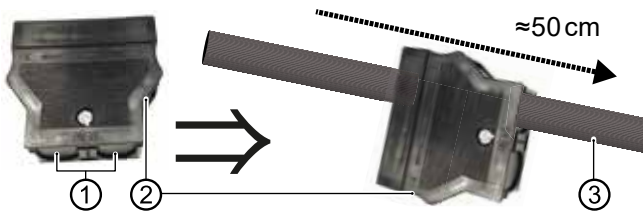

- Strip the load cable 55 mm.



- Shorten the live wires so that the PE conductor has a lead of 8 mm.  
Example of a five-wire load cable:



- Strip each wire 9 mm.  
Example of a five-wire load cable:



- Insert the stripped wires into the pins (④).  
Example of a five-wire load cable:

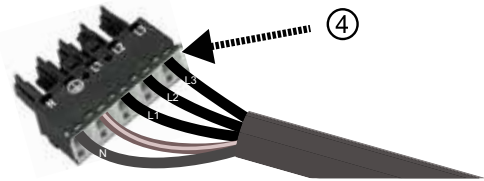

- ▶ If the load cable has single wires, insert each of them as far as they will go:

With a three-wire load cable (230V compressor at 8kW device), insert the N and PE conductor in the pins labelled accordingly and insert the L conductor in the L1 pin.

With a five-wire load cable (400V compressor at 12kW device), insert the N, PE, L1, L2 and L3 wires in the corresponding pins.

- ▶ If the load cable has fine wire strands:

- Twist the strands of each wire.  
Example of a five-wire load cable:

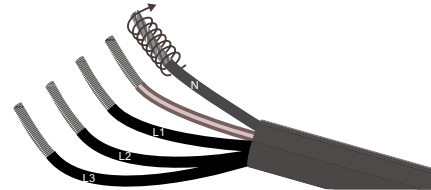

- 1.5.1. Insert an operating tool or screwdriver (2.5 mm blade width) in the connection lock of the neutral conductor pin to unlock the connection lock.

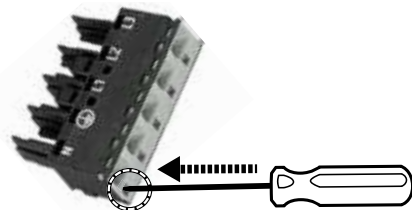

- 1.5.2. Insert the twisted wire of the neutral conductor as far as it will go into the neutral conductor pin.  
Example of a five-wire load cable:

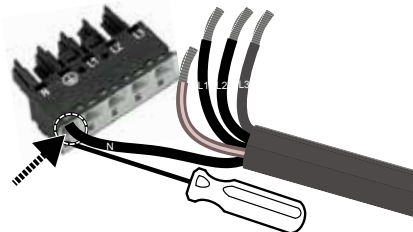



1.5.3. Pull the operating tool or screwdriver out of the connection lock pin to lock the connection.  
Example of a five-wire load cable:

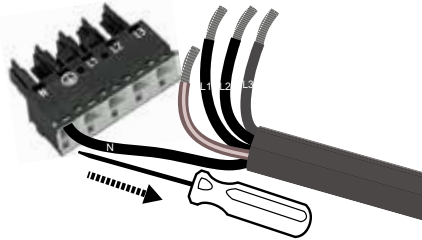

1.5.4. Insert the PE conductor and L conductor in the same way in the corresponding pins:

With a three-wire load cable (230V compressor at 8kW device), insert the PE conductor in the pin labelled accordingly and insert the L conductor in the L1 pin.

With a five-wire load cable (400V compressor at 12kW device), insert the L1, L2 and L3 wires in the corresponding pins.

**IMPORTANT**

Check each inserted wire for tight fitting in its pin.

1.6. Push the strain relief housing (2) onto the wired socket (4).

Example of a five-wire load cable:



1.7. Align them correctly to each other: The top side of the socket and the top side of the strain relief housing are both marked with "TOP".

1.8. Push the socket as far as it will go into the strain relief housing.



1.9. Lock the top part of the strain relief housing firmly onto the bottom part.

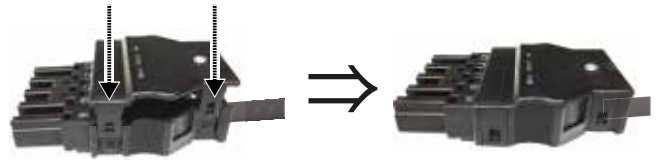

1.10. Screw the strain relief screw tight.

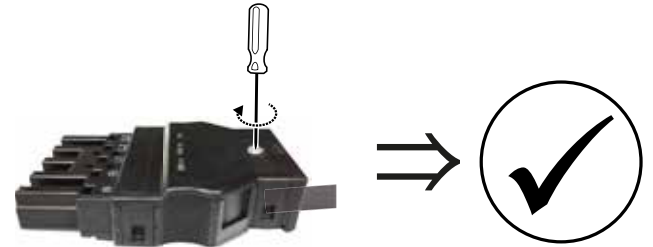

2. Connect the bus cable (communication) to the bus cable socket.



2.1. Insert the contact spring (5) into pin 3 (6) up to the limit stop.

The lugs on the broad end of the contact spring must point upwards (in the direction of the numbers on the socket).

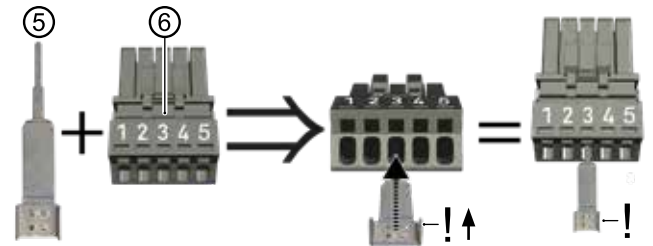

**NOTE**

If the contact spring is in the way when subsequently inserting the wires of the bus cable, it can be disconnected and re-connected after inserting the wires.

2.2. Strip the bus cable 30 mm.





2.3. Push the shielding braid back 10 mm over the sheath.

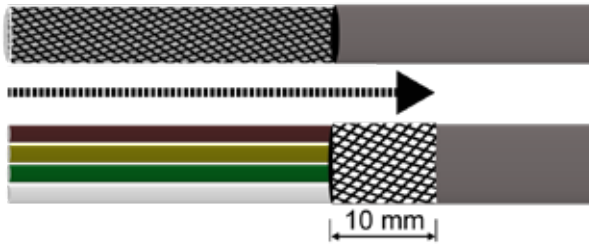

2.4. Pull back the shielding foil up to the shielding braid and cut off.

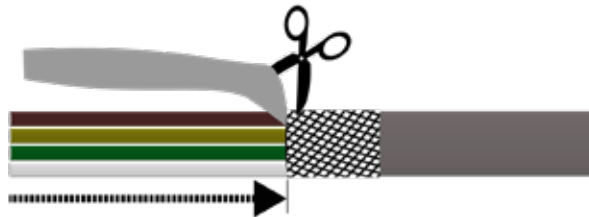

2.5. Strip each wire 9 mm.

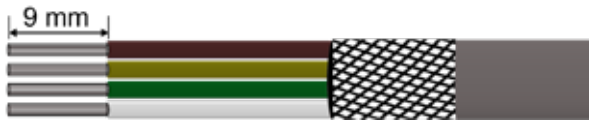

2.6. Twist the strands of each wire.



2.7. Insert the stripped wires into the pins.

2.7.1. Insert an operating tool or screwdriver (blade 2.5x0.4mm) in the connection lock on pin 5 to unlock connection lock.

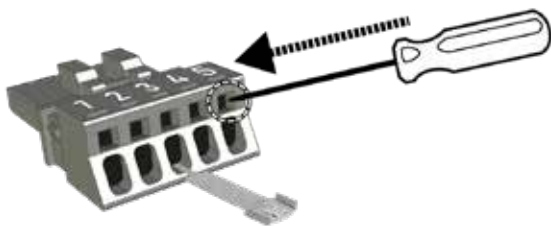

2.7.2. Place the cable with shielding braid onto the contact spring from above and insert the brown wire into pin 5 up to the limit stop.

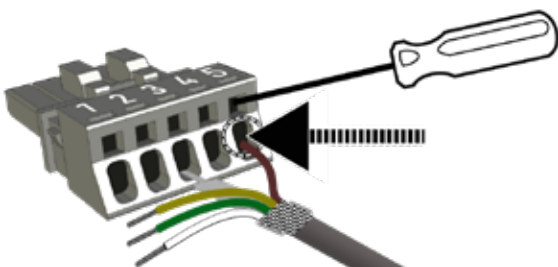

2.7.3. Pull the operating tool or screwdriver out of the connection lock pin to lock the connection.

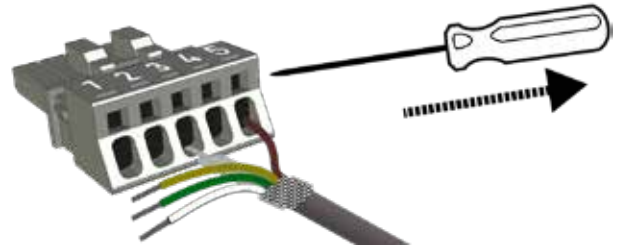

2.7.4. Insert the three other wires in the same way into the corresponding pins.

Assignments of the pins

white wire of the bus cable	pin 1
green wire of the bus cable	pin 2
Shielding braid on contact spring	pin 3
yellow wire of the bus cable	pin 4
brown wire of the bus cable	pin 5

### IMPORTANT

Check each inserted wire for tight fitting in its plug pin.

2.8. Place the shielding braid on the contact spring and, if necessary, shorten it so that it does not go beyond the contact spring.

2.9. Assemble the strain relief housing.

2.9.1. Snap the wired socket into the lower part (⑦) of the strain relief housing.

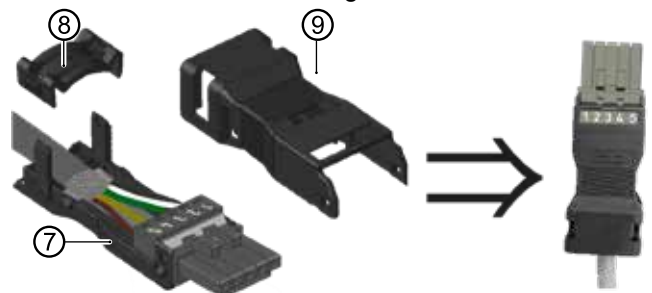

2.9.2. Fit the strain relief (⑧) and clip into place until the bus cable is clamped firmly.

### IMPORTANT

The shielding braid must have a direct and firm contact with the contact spring.

2.9.3. Snap the upper part of the housing (⑨) fully on to the lower part.





3. Connect the wired sockets of the load cable and the bus cable to the unit.

3.1. Remove the cover (①) for the plug-in connections on the back of the unit.

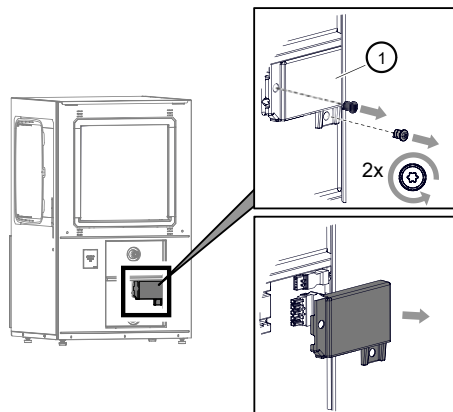

3.2. Open the strain reliefs on the unit.

3.3. Insert the load cable socket (③) and bus cable socket (②) up to the limit stop into the corresponding plugs.

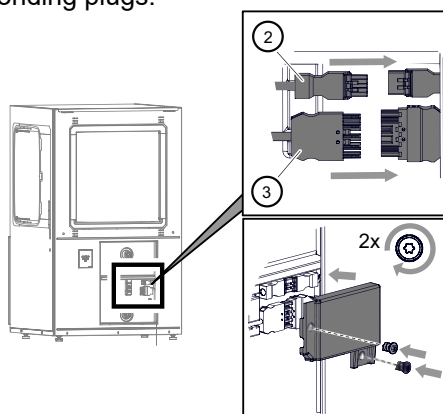

3.4. Route both cables through the strain reliefs, close the strain reliefs and tighten the strain reliefs.

3.5. Mount the cover of the plug-in connections.

4. Guide the load and bus cable from the heat pump to the electrical switch box of the hydraulic unit or to the wall-mounted controller.

5. Mount the plugs on the load cable and the bus cable in the same way as the sockets.

### IMPORTANT

The wire assignment of the bus cable plug must match the wire assignment of the bus cable socket.

→ “Assignments of the pins”, page 16

6. Insert the load cable plug and bus cable plug up to the limit stop into the corresponding sockets on the underside of the electrical switch box of the hydraulic unit or in the wall-mounted controller.

→ Operating manual of the hydraulic unit or

→ Operating manual of the wall-mounted controller

## 8 Flushing, filling and venting

### 8.1 Heating water quality



#### NOTE

For detailed information refer, among other things, to the VDI Guidelines 2035 “Vermeidung von Schäden in Warmwasserheizanlagen” (preventing damage in hot water heating systems).

1. Ensure that the pH-value of the heating water is between 8.2 – 10, for aluminium materials between 8.2 – 9.

Ideally, the pH value should already be in the required range after filling. After 6 weeks at the latest, it must have adjusted to the required range.

2. Ensure that the electrical conductivity is  $< 100 \mu\text{S/cm}$ .



#### NOTE

If the required water quality is not achieved, consult a company specialising in the treatment of heating water.

3. Fill the system with deionised heating water (VE water) or with water corresponding to the VDI 2035 norm only (low-salt operation of the system).

Advantages of low-salt operation:

- Low corrosion-promoting properties
- No formation of mineral scale
- Ideal for closed heating circuits

4. Keep a system log for hot water heating systems in which relevant planning data and the water quality are entered (VDI 2035).



## 8.2 Flush, fill and vent the heating circuit

- ✓ Outlet pipe of the safety valve is connected.
- ▶ Ensure that the set pressure of the safety valve is not exceeded.

### IMPORTANT

Flush the heating circuit only in its flow direction.



#### NOTE

The venting program on the controller can also be used to support the flushing and venting process. It is possible to control individual recirculating pumps and even the switching valve through the venting program. The valve motor then does not have to be removed.

1. Pull the U-clip off the floor of the valve motor.
2. Pull the valve motor carefully off the 3-way switching valve.
3. Vent system at the respective highest point.
4. Vent heat pump.

## 9 Insulate hydraulic connections

Insulate hydraulic lines in accordance with local regulations.

1. Open shut-off devices.
2. Perform a pressure test and check for leaks.
3. Insulate external piping on site.
4. Insulate all connections, fittings and pipes. If the device is used for cooling below 18°C, the insulation must be vapour diffusion-tight.

## 10 Set the overflow valve



#### NOTE

- The activities in this section are only necessary for the integration of storage tanks in series
  - Complete the work steps quickly, otherwise the maximum return temperature may be exceeded and the heat pump switches to high-pressure fault
  - Turn the adjusting knob at the overflow valve to the right to increase the temperature difference (the temperature drop), turn it to the left to reduce it
- ✓ System is running in heating mode (ideally in cold condition).

The IBN assistant already provides the option, in the event of the integration of the storage tank in series to adjust the overflow valve according to the hydraulic system.

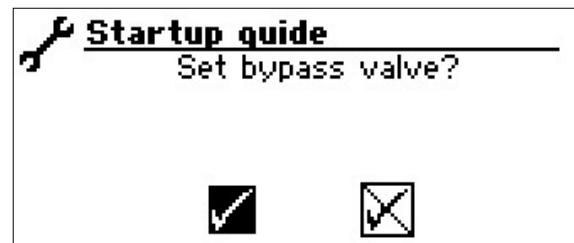

Confirm the IBN assistant or:

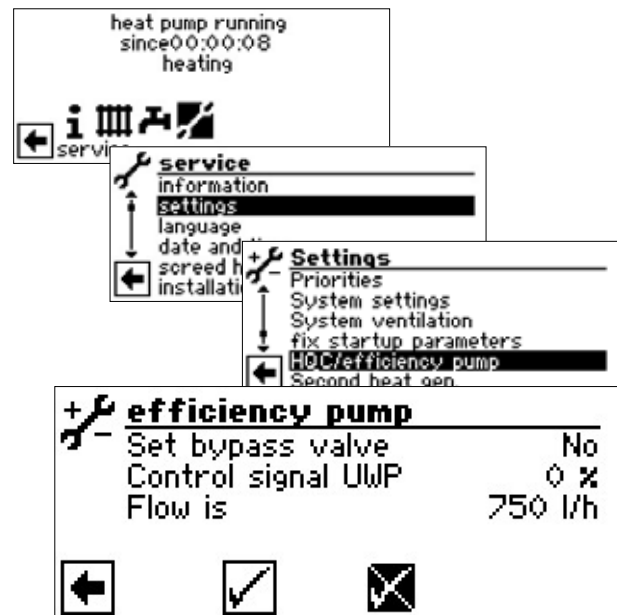

The “Set bypass valve” menu item is set by default to “No”. The overflow valve adjustment function is deactivated.



- The UWP control signal is the indication of the currently required pump capacity in %
  - If the flow rate is the current flow rate (measuring accuracy +/- 200 l/h)
1. Fully open the overflow valve, close the heating circuits
  2. If the "Set bypass valve" menu item is set from "No" to "Yes", the circulation pump is activated with 100% – and the pump starts up.
  3. If the control signal UWP reaches 100%, close the overflow valve to the extent that the maximum flow rate (→ "Technical data / Scope of supply", page 22) can be ensured.

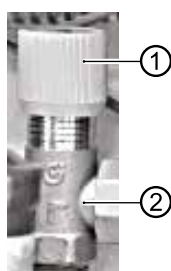

- 1 Rotary-push button
- 2 Overflow valve

4. If you exit the "Set bypass valve" menu or at the latest after one hour, the circulation pump switches back to standard regulation
5. Open valves to heating circuit.

## 11 Commissioning



### CAUTION

The unit may only be started up if the air ducts, weather and/or rain louvres have been installed and the facing panels are closed.

- ✓ Relevant planning & design data of the system is documented in full
  - ✓ The competent energy supplier has been notified of operation of the heat pump system
  - ✓ System is air-free
  - ✓ Installation check using the rough checklist has been completed successfully
  - ✓ Clockwise rotating load infeed field is present at the compressor (only applies to units with 400V connection)
  - ✓ The system is installed and mounted in accordance with this operating manual
  - ✓ The electrical installation has been carried out properly in accordance with this operating manual and local regulations
  - ✓ The power supply for the heat pump is equipped with an all-pole circuit-breaker with at least 3 mm contact spacing (IEC 60947-2)
  - ✓ The level of the tripping current is compliant
  - ✓ Heating circuit is flushed and vented
  - ✓ All shut-off devices of the heating circuit are open
  - ✓ The pipe systems and components of the system are leak-tight
1. Carefully fill in and sign the notice of completion for the heat pump systems.
  2. In Germany: Send notice of completion for heat pump systems and general checklist to the manufacturer's factory customer service department. In other countries: Send notice of completion for heat pump systems and general checklist to the manufacturer's local partner.
  3. Arrange for the heat pump system to be commissioned by the manufacturer's authorised after sales service for a fee.
- "12.2 Maintenance after commissioning", page 20



## 12 Maintenance



### NOTE

We recommend that you conclude a maintenance agreement with an accredited heating company.

### 12.1 Basic principles

The cooling circuit of the heat pump requires no regular maintenance.

Local regulations among other things, require leak checks beforehand and/or for a logbook to be kept for certain heat pumps.

- ▶ Ensure compliance with local regulations with regard to the specific heat pump system.

### 12.2 Maintenance after commissioning

Immediately after commissioning, check all installed dirt traps for dirt and clean them if necessary.

- ▶ Switch off the system while the check and cleaning is being carried out.

Next checking and cleaning at the latest 2 weeks after commissioning.

### 12.3 Maintenance as required

- ▶ Checking and cleaning the components of the heating circuit, e.g. valves, expansion vessels, recirculating pumps, filters, dirt traps.

- ▶ The air intake and exhaust openings must always be free of obstructions and kept clear. Therefore, check for unimpeded air infeed accordingly. Constrictions or even blockages which, for example occur

- when applying house insulation with polystyrene balls
- through packaging material (foils, films, cartons etc.)
- through foliage, snow, icing or similar weather-related deposits
- through vegetation (bushes, tall grass etc.)
- through air shaft covers (fly protection screens etc.)

and which must be prevented and/or removed immediately.

- ▶ Check at regular intervals that the condensate can drain out of the device freely, without obstruction. To this end, check the condensate pan in the device regularly for dirt/clogging and clean as necessary. Also check the evaporator from all sides and clean if necessary.

#### Check evaporator and condensate pan and clean if required

1. Remove the front panel and the cover, thus gaining access to the cleaning opening (①).

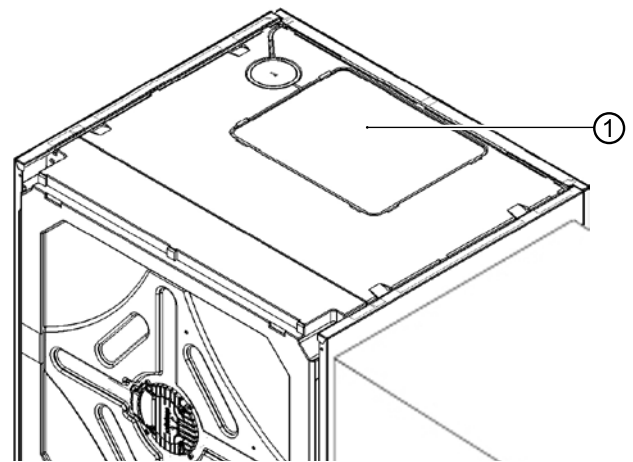

2. After the cover is removed (①), the entire condensate pan area before (②) and after (③) the evaporator is visible and can be cleaned if necessary.

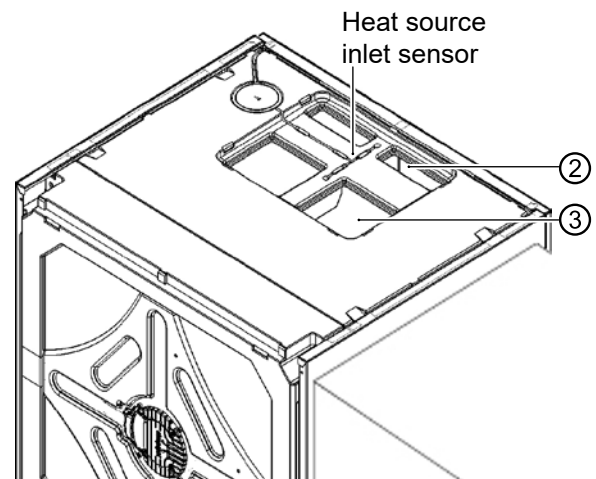

As an alternative, the lateral air ducts, the side walls, the louvre grilles and blind covers can be removed (if necessary also the fan module), to obtain better access.

- “Optional disconnection of the fan module“, page 9



## 12.4 Clean and flush condenser

- ▶ Clean and flush the condenser in accordance with the manufacturer's instructions.
- ▶ After flushing the condenser with chemical cleaning product: neutralise any residues and flush the condenser thoroughly with water.

## 12.5 Yearly maintenance

- ▶ Record the quality of the heating water analytically. In case of deviations from the specifications, take suitable measures without delay.
- ▶ Check all installed dirt traps for dirt and clean them if necessary.
- ▶ Test the function of the safety valve for the heating circuit.

## 13 Faults

1. Read out the cause of the fault via the diagnostics program of the heating and heat pump controller.
2. Contact the local partner of the manufacturer or the factory's customer service. Have the fault message and unit number to hand.

→ "Nameplates", page 7

## 14 Dismantling and disposal

### 14.1 Dismantling

- ▶ Collect all substances safely.
- ▶ Separate components according to their materials.

### 14.2 Disposal and recycling

- ▶ Dispose of environmentally hazardous substances (e.g. refrigerant, compressor oil) according to the local regulations.
- ▶ Recycle or ensure proper disposal of unit components and packaging materials in accordance with local regulations.



# Technical data / Scope of supply

LWV

Performance data		Values in brackets: (1 Compressor)		LWV 82R1/3	LWV 122R3
Heating capacity   COP	for A10/W35 acc. to DIN EN 14511-x: 2013	Partial load operation	kW   COP	3.18   5.25	5.50   5.10
	for A7/W35 acc. to DIN EN 14511-x: 2013	Partial load operation	kW   COP	2.81   5.03	5.29   4.71
	for A7/W55 acc. to DIN EN 14511-x: 2013	Partial load operation	kW   COP	3.28   2.85	9.36   2.65
	for A2/W35 acc. to DIN EN 14511-x: 2013	Partial load operation	kW   COP	3.82   4.19	5.00   4.01
	for A-7/W35 acc. to DIN EN 14511-x: 2013	Full load operation	kW   COP	6.40   3.17	8.50   2.63
	for A-7/W55 acc. to DIN EN 14511-x: 2013	Full load operation	kW   COP	4.93   2.20	8.46   2.05
Heating capacity	for A10/W35	min.   max.	kW   kW	2.90   7.00	5.40   11.0
	for A7/W35	min.   max.	kW   kW	2.80   6.60	5.40   11.0
	for A7/W55	min.   max.	kW   kW	2.50   6.40	4.50   11.0
	for A2/W35	min.   max.	kW   kW	2.60   6.40	4.60   10.3
	for A-7/W35	min.   max.	kW   kW	2.30   6.50	3.60   8.50
	for A-7/W55	min.   max.	kW   kW	1.80   4.95	2.80   8.50
Cooling capacity   EER	for A35/W18	Partial load operation	kW   EER	3.20   2.10	7.20   3.70
	for A35/W7	Partial load operation	kW   EER	2.70   1.80	6.30   3.20
Cooling capacity	for A35/W18	min.   max.	kW   kW	2.00   4.60	4.70   8.50
	for A35/W7	min.   max.	kW   kW	1.50   4.00	3.70   8.50
Heating capacity domestic hot water preparation			kW	5	8
<b>Operating limits</b>					
Heating circuit return min.   Heating circuit flow max. Heating		within heat source min./max.	°C	20   45	20   45
Heat source, heating		min.   max.	°C	-22   35	-22   35
Additional operating points		...		A-5 / W60	A-5 / W60
<b>Sound</b>					
Sound power level inside		min.   Night   max.	dB(A)	43   53   54	43   53   54
Sound power level outside 1)		min.   Night   max.	dB(A)	34   38   44	30   43   49
Sound power level acc. to DIN EN 12102-1:2017		inside   outside	dB(A)	48   44	47   49
Tonality   Low-frequency		dB(A)   • yes – no		–   –	–   –
<b>Heat source</b>					
Air flow rate at maximum external pressing   Maximum external pressure			m³/h   Pa	2500   25	2900   25
<b>Heating circuit</b>					
Flow rate (pipe dimensioning)   Min. volume buffer tank in series   Min. volume separation buffer tank			l/h   l   l	1200   60   100	1900   100   200
Free pressing   Pressure loss   Flow rate			bar   bar   l/h	–   0.14   1200	–   0.2   1900
Max. allowable operating pressure			bar	3	3
Circulation pump control range			min.   max.	l/h	–   –
<b>General unit data</b>					
Total weight			kg	138,00	154,00
Weight of heat pump module   Compact module   Fan module			kg   kg   kg	88   –   16	104   –   16
Refrigerant type   Refrigerant capacity			...   kg	R410A   3.00	R410A   3.60
<b>Electrics</b>					
Voltage code   all-pole fuse protection for heat pump **)*)			...   A	1~N/PE/230V/50Hz   B16	3~N/PE/400V/50Hz   B16
Voltage code   Control voltage fuse protection **)			...   A	1~N/PE/230V/50Hz   B10	1~N/PE/230V/50Hz   B10
Voltage code   Electric heating element fuse protection **)			1 phase	...   A	–
Voltage code   Electric heating element fuse protection **)			3 phases	...   A	–
HP*): effect. Power consumption A7/W35 (partial load operation) DIN EN 14511-x: 2013   Electric consumption   cosφ			kW   /	0.559   1.09   0.83	1.12   2.40   0.83
HP*): effective power consumption A7/W35 acc. to DIN EN 14511-x: 2013: min.   max.			kW   kW	0.5   –	1.12   –
HP*): Max. machine current   Max. power consumption within the operating limits			A   kW	16   3.5	13   6.0
Starting current: direct   with soft starter			A   A	< 5   –	< 5   –
Degree of protection			IP	20	20
Residual current circuit breaker if required			type	B	B
Electric heating element output			3   2   1 phase	kW   kW   kW	–   –   –
Circulation pump power consumption, heating circuit			min.   max.	W	–
<b>Other unit information</b>					
Safety valve heating circuit   Response pressure			included in scope of supply: • yes – no   bar	–   –	–   –
Buffer tank   Volume			included in scope of supply: • yes – no   l	–   –	–
Heating circuit expansion vessel   Volume   Prepressure			incl. in scope of supply: • yes – no   l   bar	–   –	–   –
Overflow valve   Changeover valve heating - domestic hot water			integrated: • yes – no	–	–   –
Heating circuit vibration decoupling			incl. in scope of supply or integrated: • yes – no	•	•
Controller   Heat quantity recording   Extension board			incl. in scope of supply or integrated: • yes – no	–   •   –	–   •   –

\*) compressor only, \*\*) note local regulations 1) Indoor and outdoor installation.  
 For indoor installation: Intake 1.5m air duct, Blow-out 1.5m air duct + air duct bend (original accessories)  
 The performance data and the operating limits apply to clean heat exchangers | Index: h

813577e

813578c



# LWV 82R1/3

# Performance curves / operating limits / heating

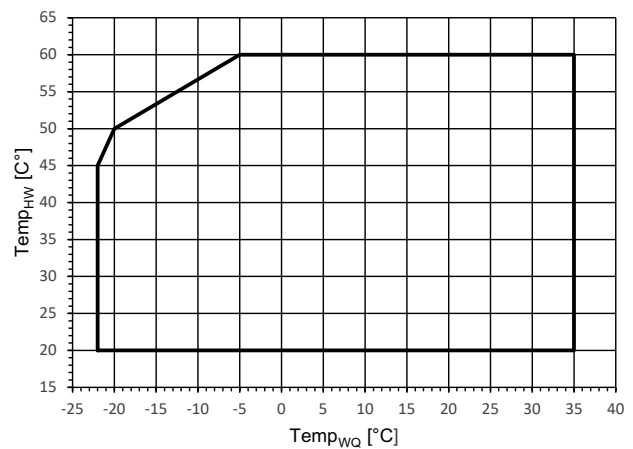
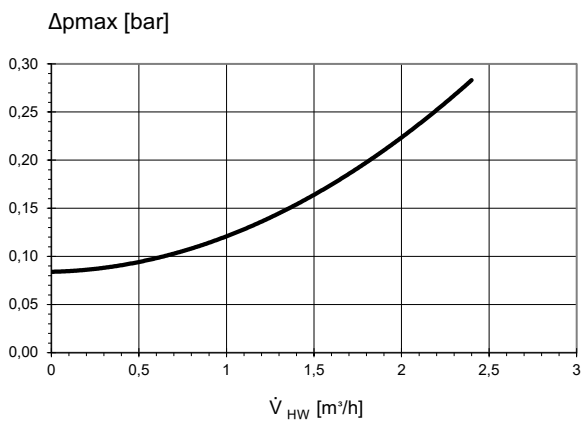
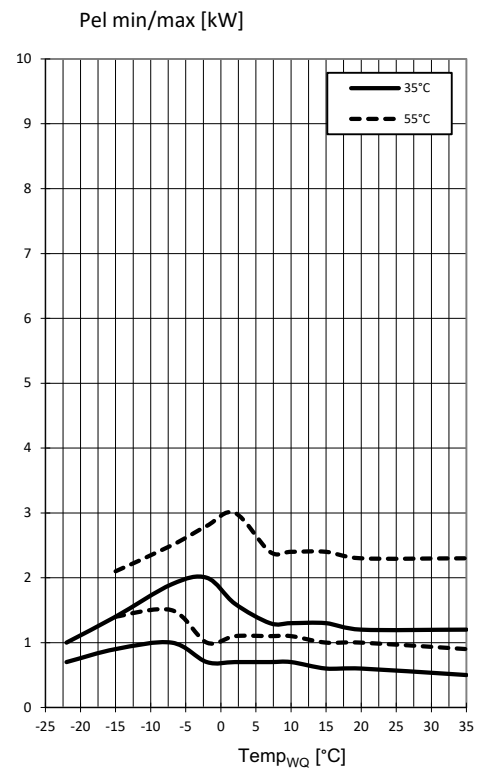
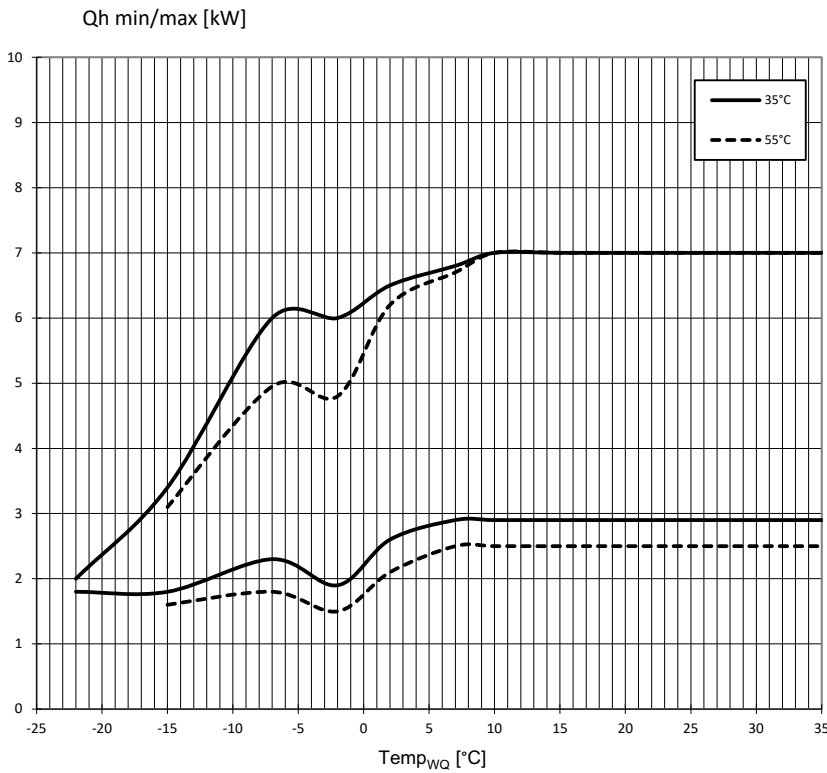

823290 c

Keys: 823290c

$\dot{V}_{HW}$	Volume flow rate heating water
Temp <sub>WQ</sub>	Heat source temperature
$\Delta p_{max}$	max. free pressing
Qh min/max	min./max. heating power
Pel min/max	min./max. power consumption



# Performance curves / cooling

LWV 82R1/3

Q0 min/max [kW]

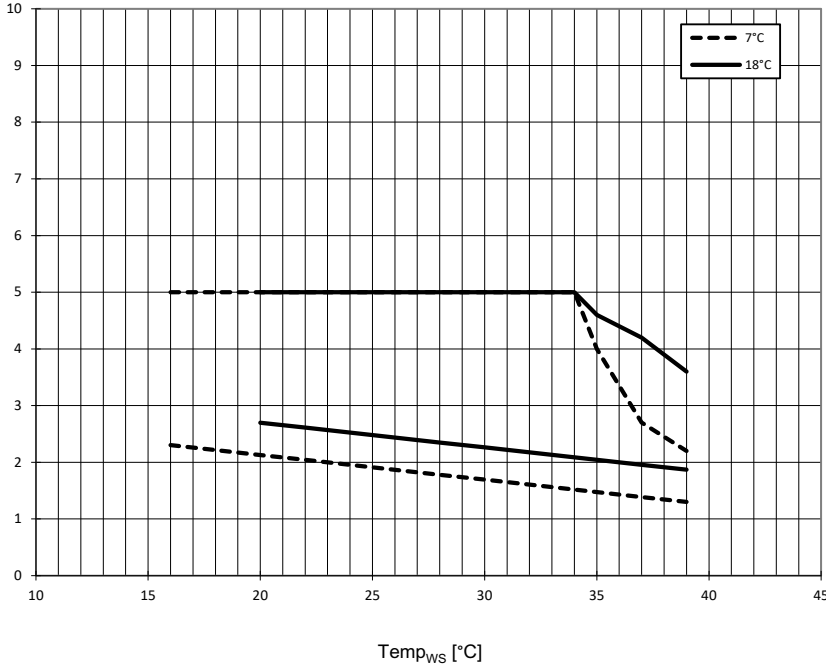

Pel min/max [kW]

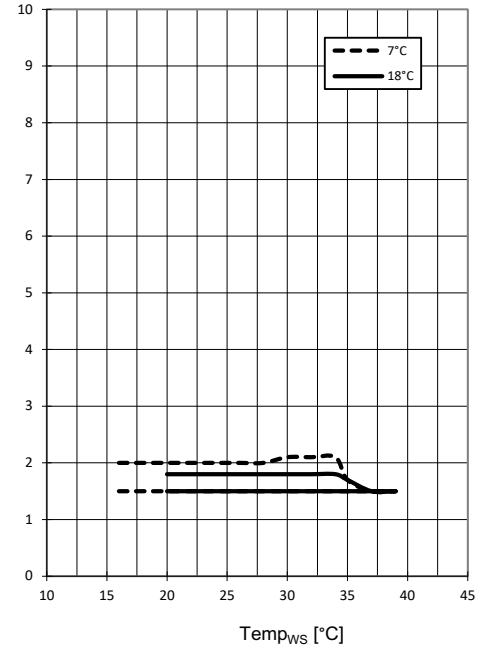

$\Delta p_{max}$  [bar]

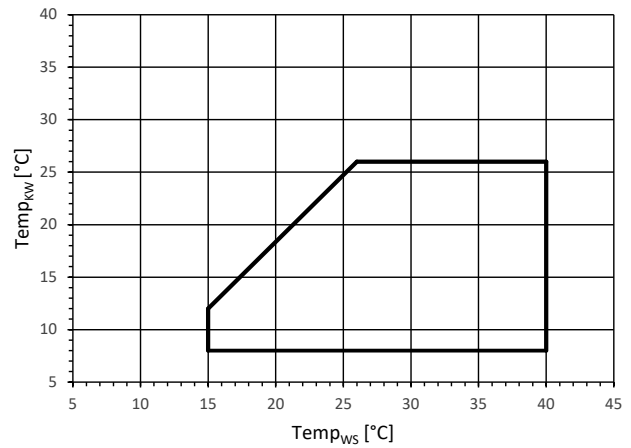
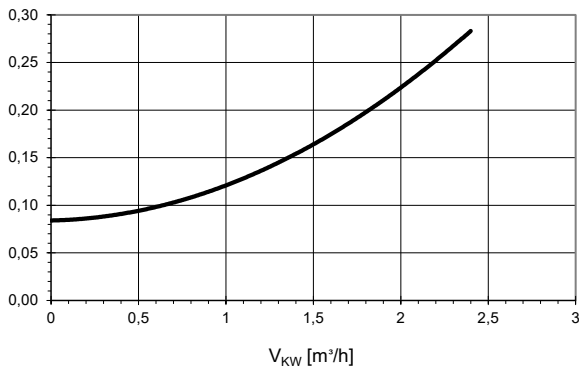

823290 c

Keys: 823290c

$\dot{V}_{KW}$	Volume flow rate cooling water
Temp <sub>ws</sub>	Heat sink temperature
$\Delta p_{max}$	max. free pressing
Q0 min/max	min./max. cooling capacity
Pel min/max	min./max. power consumption





# LWV 122R3

# Performance curves / operating limits / heating

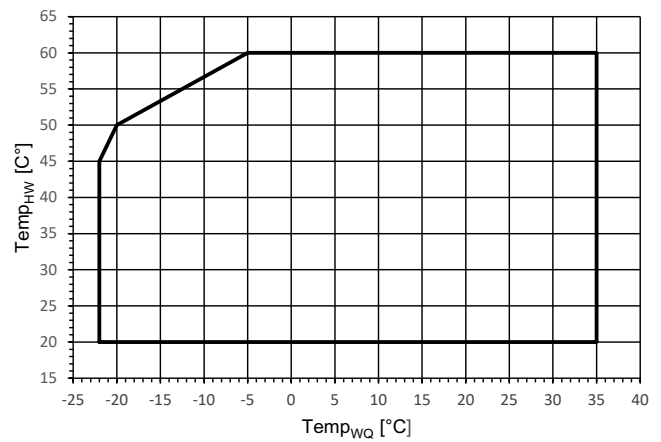
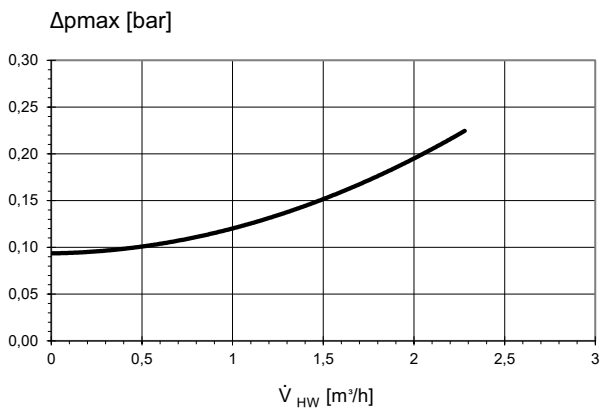
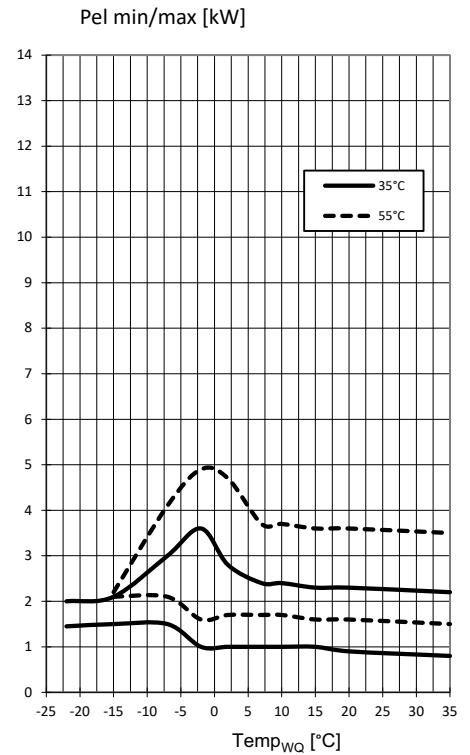
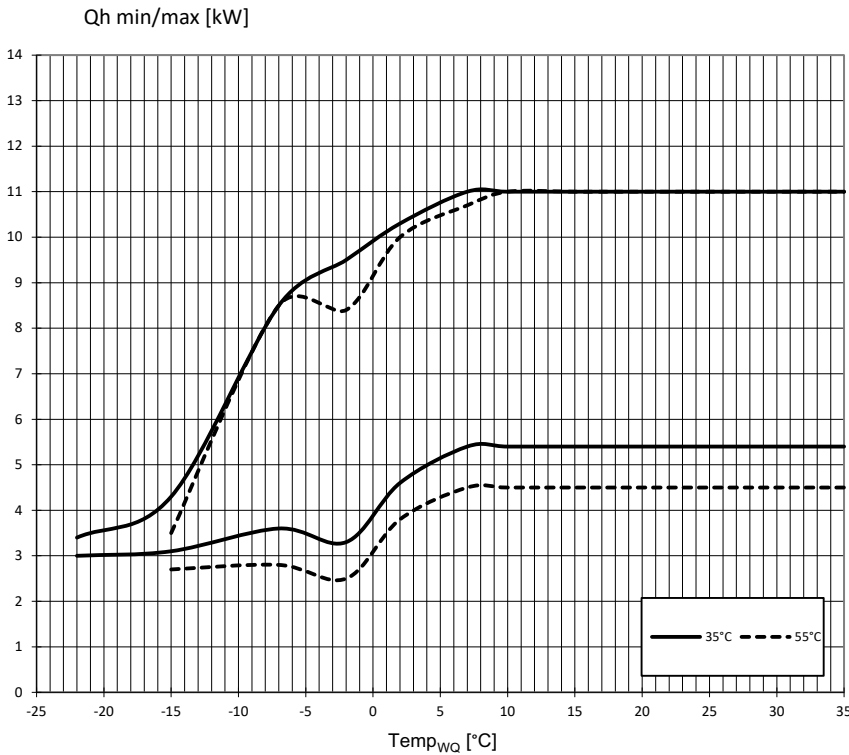

823291 c

Keys: 823291c

$\dot{V}_{HW}$	Volume flow rate heating water
Temp <sub>wQ</sub>	Heat source temperature
Δpmax	max. free pressing
Qh min/max	min./max. heating power
Pel min/max	min./max. power consumption



# Performance curves / cooling

LWV 122R3

Q0 min/max [kW]

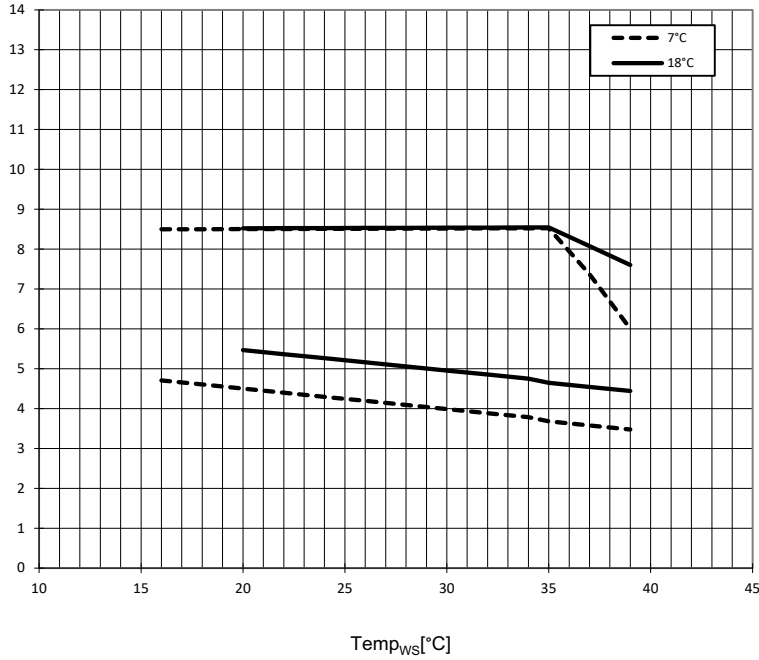

Pel min/max [kW]

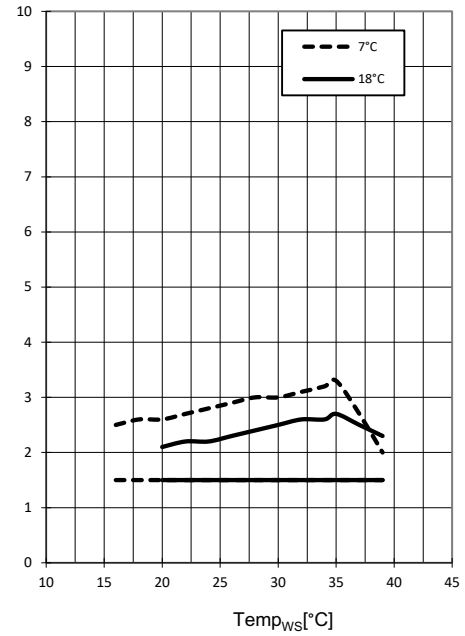

Δpmax [bar]

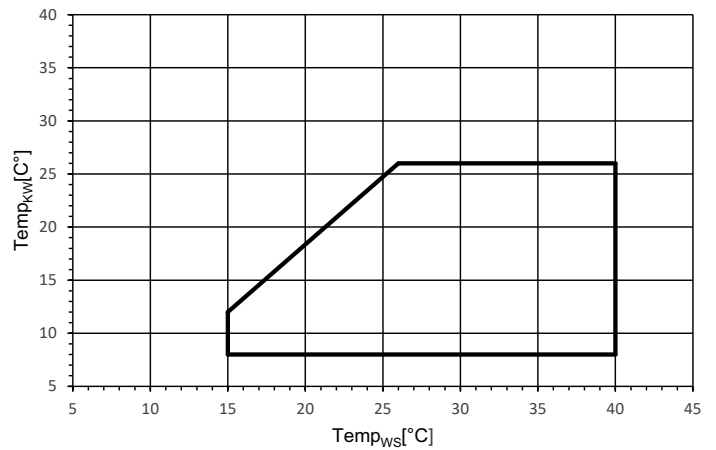
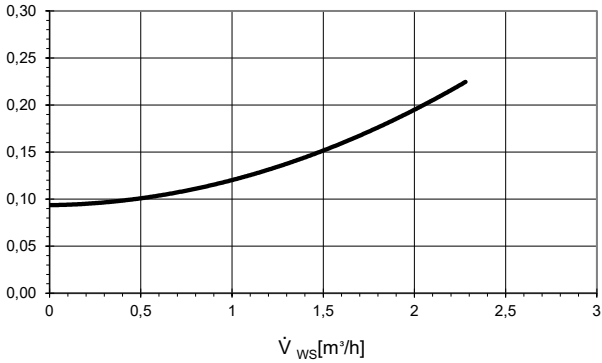

823291 c

Keys: 823291c

$\dot{V}_{KW}$	Volume flow rate cooling water
Temp <sub>ws</sub>	Heat sink temperature
Δpmax	max. free pressing
Q0 min/max	min./max. cooling capacity
Pel min/max	min./max. power consumption



LWV

Dimensional drawing 1

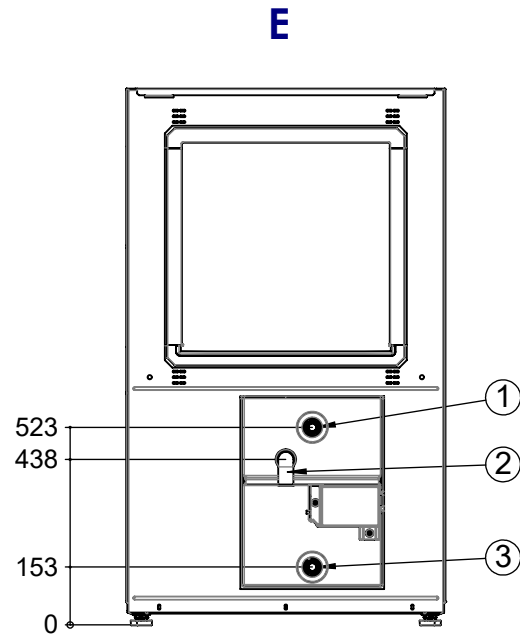
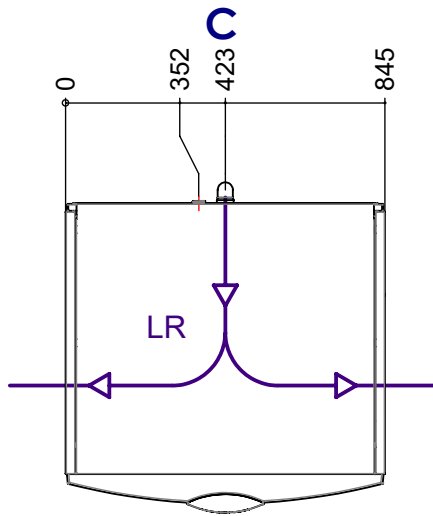
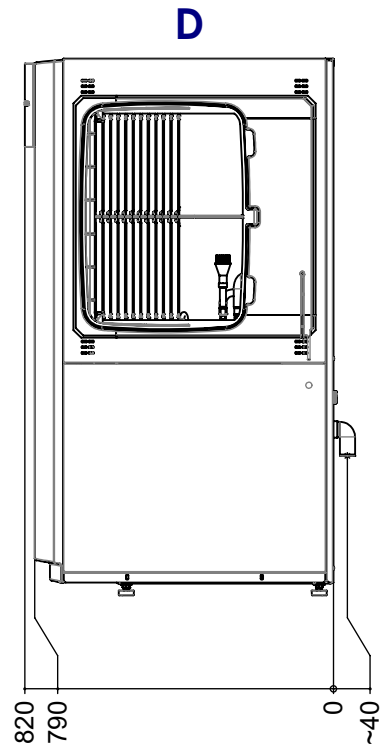
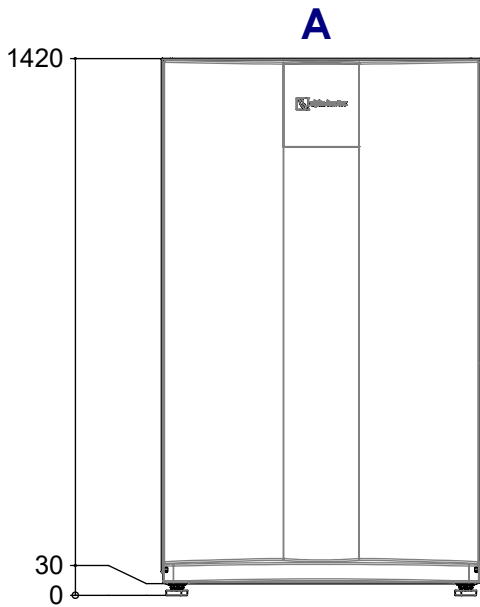

Keys: UK819476a  
All dimensions in mm.

Pos.	Name
A	Front view
C	Top view
D	Side view from right
E	Rear view without piping
LR	Air direction (left or right, can be selected on site)

Pos.	Name	Dim. 8kW	Dim. 12kW
1	Heating water outlet (flow)	G 1" External thread	G ¾" External thread
2	Condensate drain HT pipe	DN 40	DN 40
3	Heating water inlet (return)	G 1" External thread	G ¾" External thread



## Dimensional drawing 2

LWV

**A1**

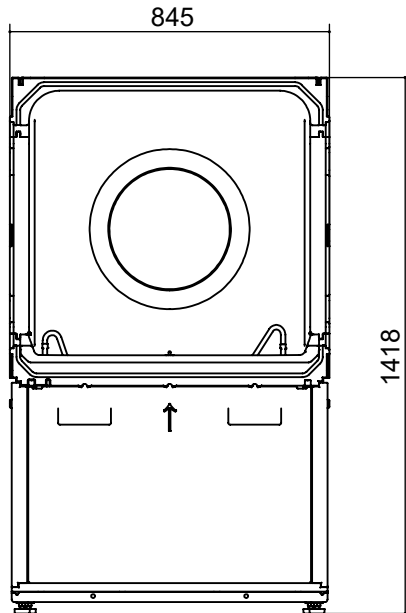

**B1**

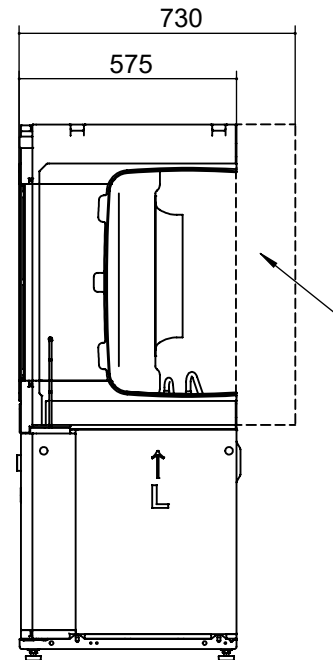

**A2**

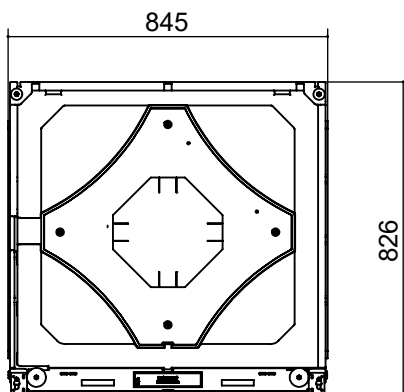

**B2**

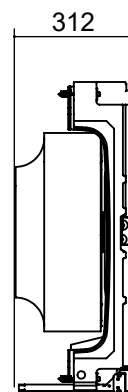

Keys: UK819476a

All dimensions in mm.

Pos.	Name
A1	Heat pump module front view
B1	Heat pump module side view from left
A2	Fan module, front view
B2	Fan module, side view from left



# LWV V1

## Installation plan V1

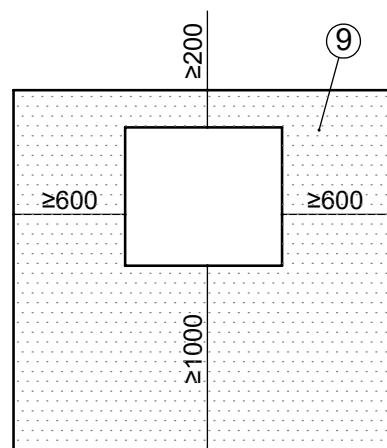
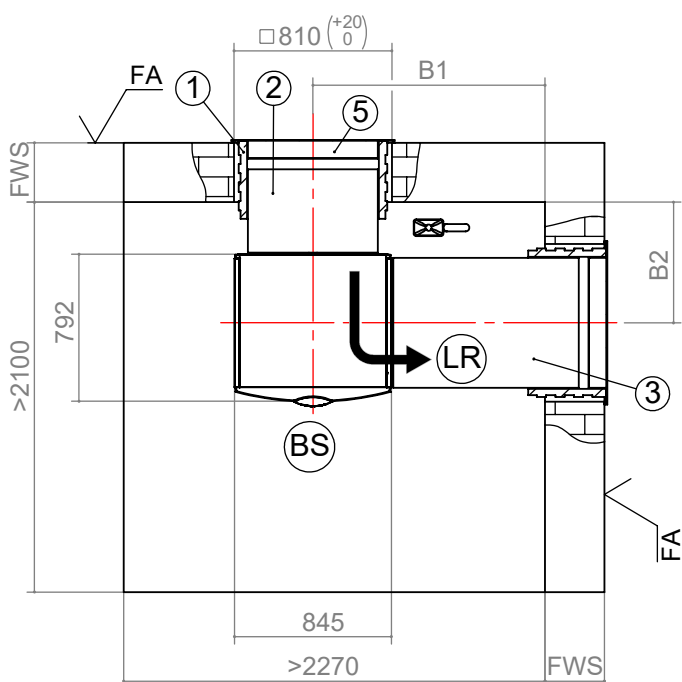
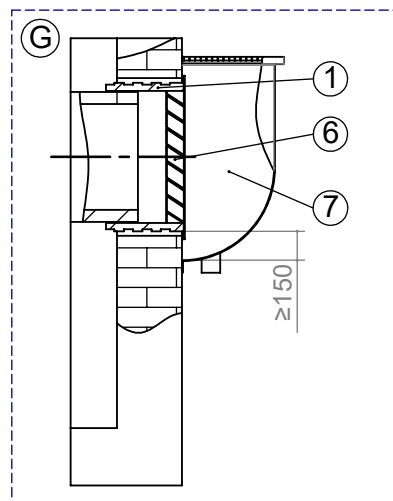
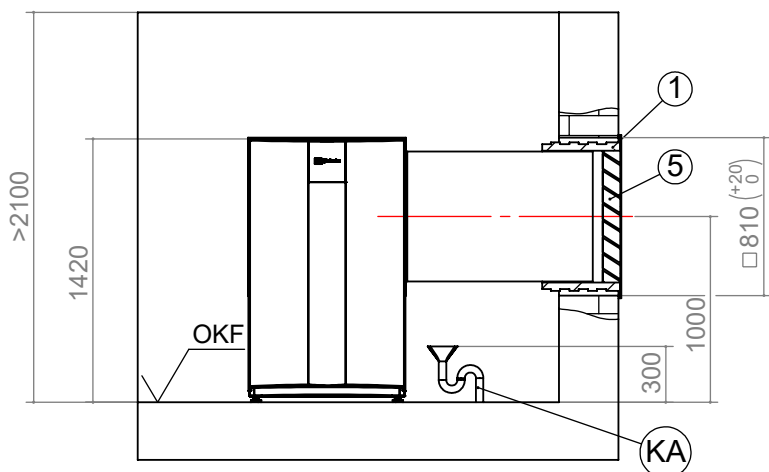

Keys: UK819471

All dimensions in mm.

V1	Version 1
OKF	Top edge of the finished floor
FA	Finished external façade
LR	Air direction
BS	Control side
FWS	Finished wall thickness
KA	Condensate drain
G	Cut: Installation in the light well

Pos.	Name	Dim.
B1	If finished wall thickness 240 to 320	1330
	If finished wall thickness 320 to 400	1250
B2	If finished wall thickness 240 to 320	730
	If finished wall thickness 320 to 400	650
1	Accessory: Wall duct 800x800x420	
2	Accessory: Air duct 700x700x450	
3	Accessory: Air duct 700x700x1000	
5	<b>Installation above ground level</b> Accessory: Weather protection grid 845x850	
6	<b>Installation in the light well</b> Accessory: Rain protection grid 845x850	
7	On site: Light well with water drain min. free cross-section 0.6 m <sup>2</sup>	
9	Minimum clearance for service purposes If clearances are reduced to the minimum dimension, the air ducts must be shortened. This causes a substantial increase in the sound pressure level!	



# Installation plan V2

LWV

## V2

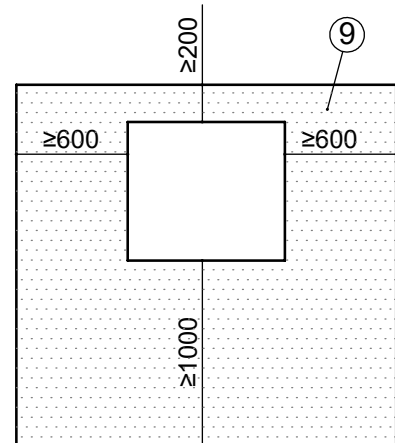
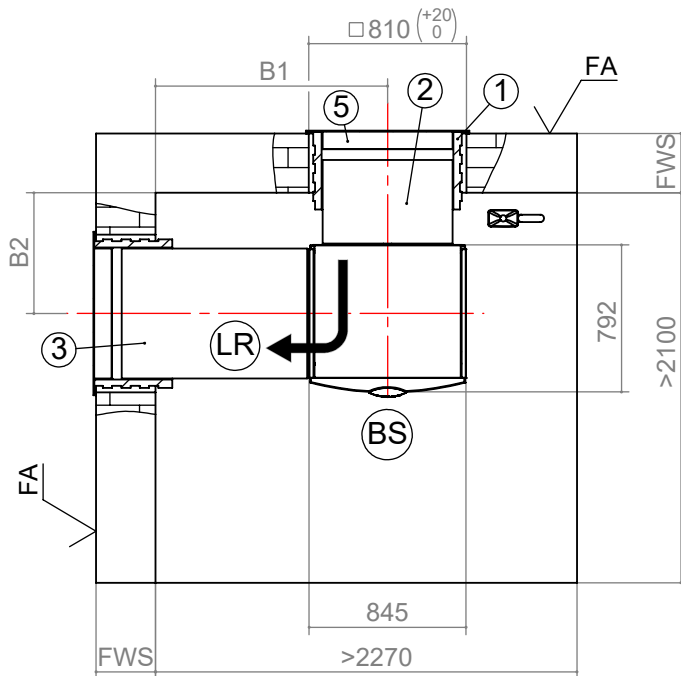
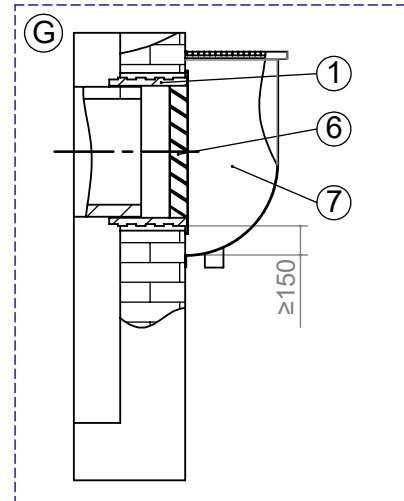
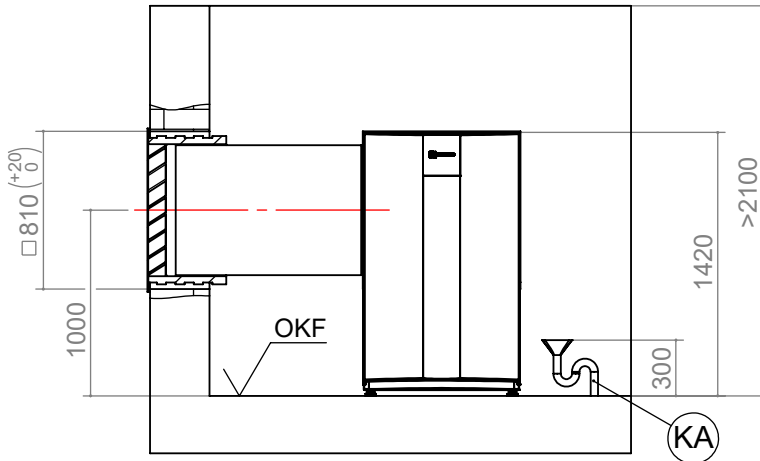

Keys: UK819471  
All dimensions in mm.

V2	Version 2
OKF	Top edge of the finished floor
FA	Finished external façade
LR	Air direction
BS	Control side
FWS	Finished wall thickness
KA	Condensate drain
G	Cut: Installation in the light well

Pos.	Name	Dim.
B1	If finished wall thickness 240 to 320	1330
	If finished wall thickness 320 to 400	1250
B2	If finished wall thickness 240 to 320	730
	If finished wall thickness 320 to 400	650
1	Accessory: Wall duct 800x800x420	
2	Accessory: Air duct 700x700x450	
3	Accessory: Air duct 700x700x1000	
5	<b>Installation above ground level</b> Accessory: Weather protection grid 845x850	
6	<b>Installation in the light well</b> Accessory: Rain protection grid 845x850	
7	On site: Light well with water drain min. free cross-section 0.6 m <sup>2</sup>	
9	Minimum clearance for service purposes If clearances are reduced to the minimum dimension, the air ducts must be shortened. This causes a substantial increase in the sound pressure level!	





# Installation plan 4

LWV

V4

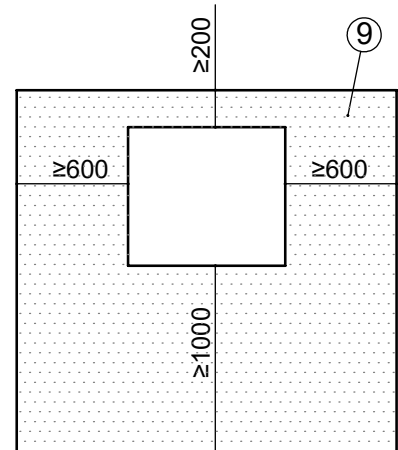
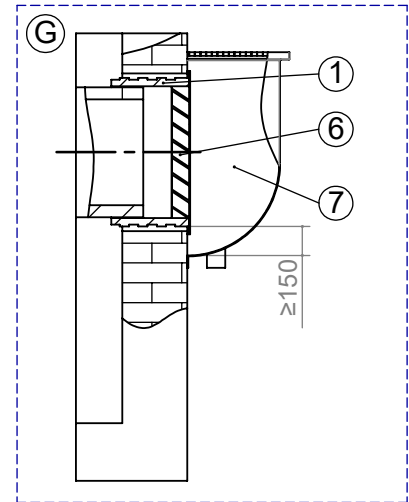
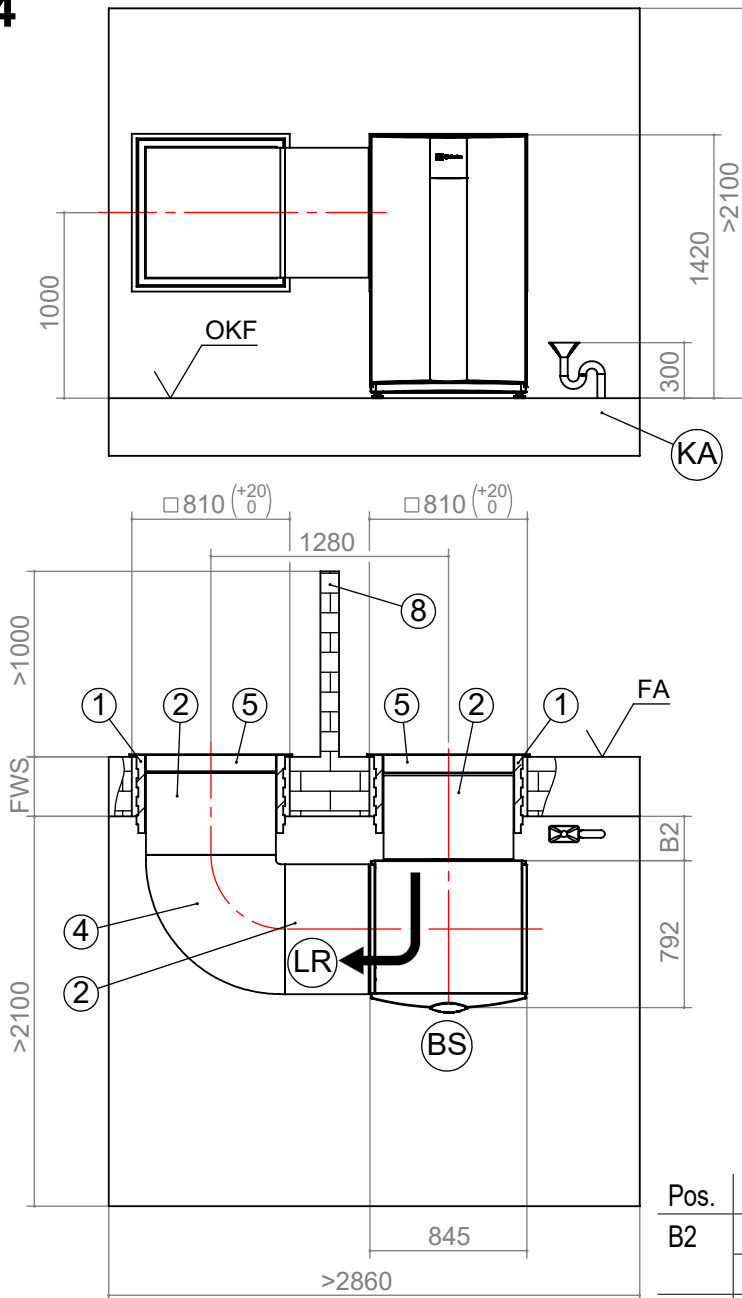

Pos.	Name	Dim.
B2	If finished wall thickness 240 to 320	355
	If finished wall thickness 320 to 400	275
1	Accessory: Wall duct 800x800x420	
2	Accessory: Air duct 700x700x450	
4	Accessory: Air duct bend 700x700x750	
5	<b>Installation above ground level</b> Accessory: Weather protection grid 845x850	
6	<b>Installation in the light well</b> Accessory: Rain protection grid 845x850	
7	On site: Light well with water drain min. free cross-section 0.6 m <sup>2</sup>	
8	Height air technical separation: if <b>installed in light well</b> : ≥ 1000 if <b>installed above ground level</b> : ≥ 1500, above weather protection grid: ≥ 300	
9	Minimum clearance for service purposes If clearances are reduced to the minimum dimension, the air ducts must be shortened. This causes a substantial increase in the sound pressure level!	

Keys: UK819471

All dimensions in mm.

V4	Version 4
OKF	Top edge of the finished floor
FA	Finished external façade
LR	Air direction
BS	Control side
FWS	Finished wall thickness
KA	Condensate drain
G	Cut: Installation in the light well





# LWV V5

## Installation plan V5

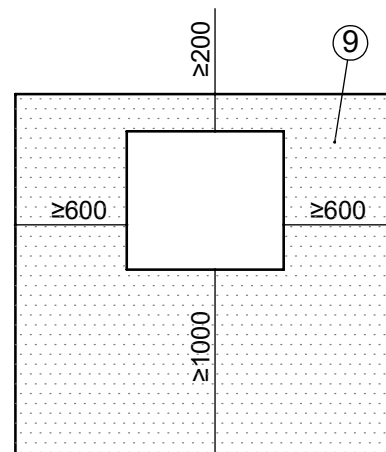
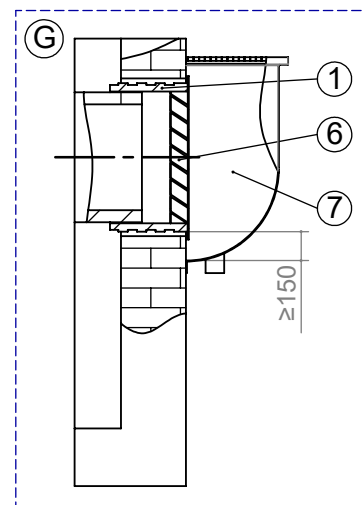
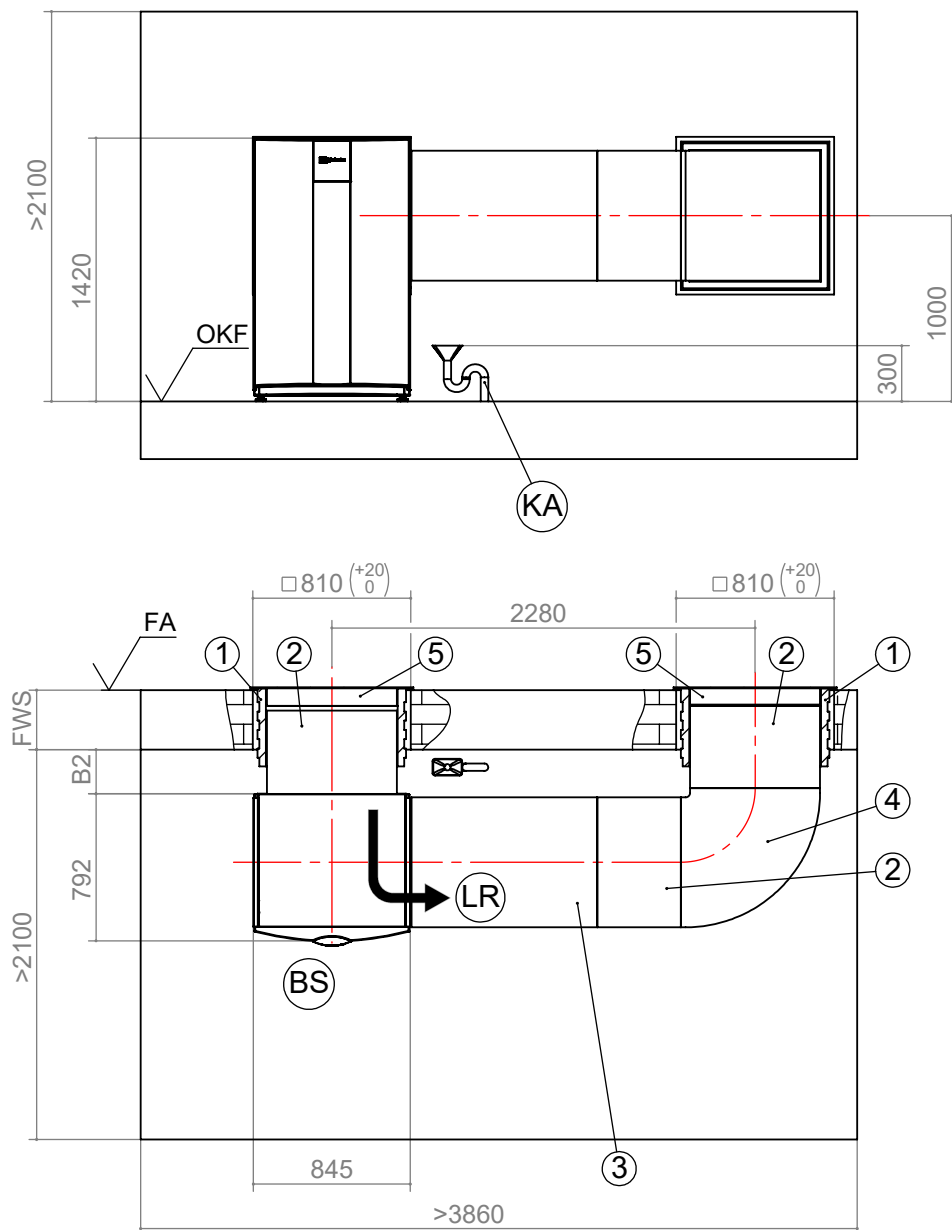

Keys: UK819471  
All dimensions in mm.

V5	Version 5
OKF	Top edge of the finished floor
FA	Finished external façade
LR	Air direction
BS	Control side
FWS	Finished wall thickness
KA	Condensate drain
G	Cut: Installation in the light well

Pos.	Name	Dim.
B2	If finished wall thickness 240 to 320	355
	If finished wall thickness 320 to 400	275
1	Accessory: Wall duct 800x800x420	
2	Accessory: Air duct 700x700x450	
3	Accessory: Air duct 700x700x1000	
4	Accessory: Air duct bend 700x700x750	
5	<b>Installation above ground level</b> Accessory: Weather protection grid 845x850	
6	<b>Installation in the light well</b> Accessory: Rain protection grid 845x850	
7	On site: Light well with water drain min. free cross-section 0.6 m <sup>2</sup>	
9	Minimum clearance for service purposes If clearances are reduced to the minimum dimension, the air ducts must be shortened. This causes a substantial increase in the sound pressure level!	



# Installation plan V6

## V6

LWV

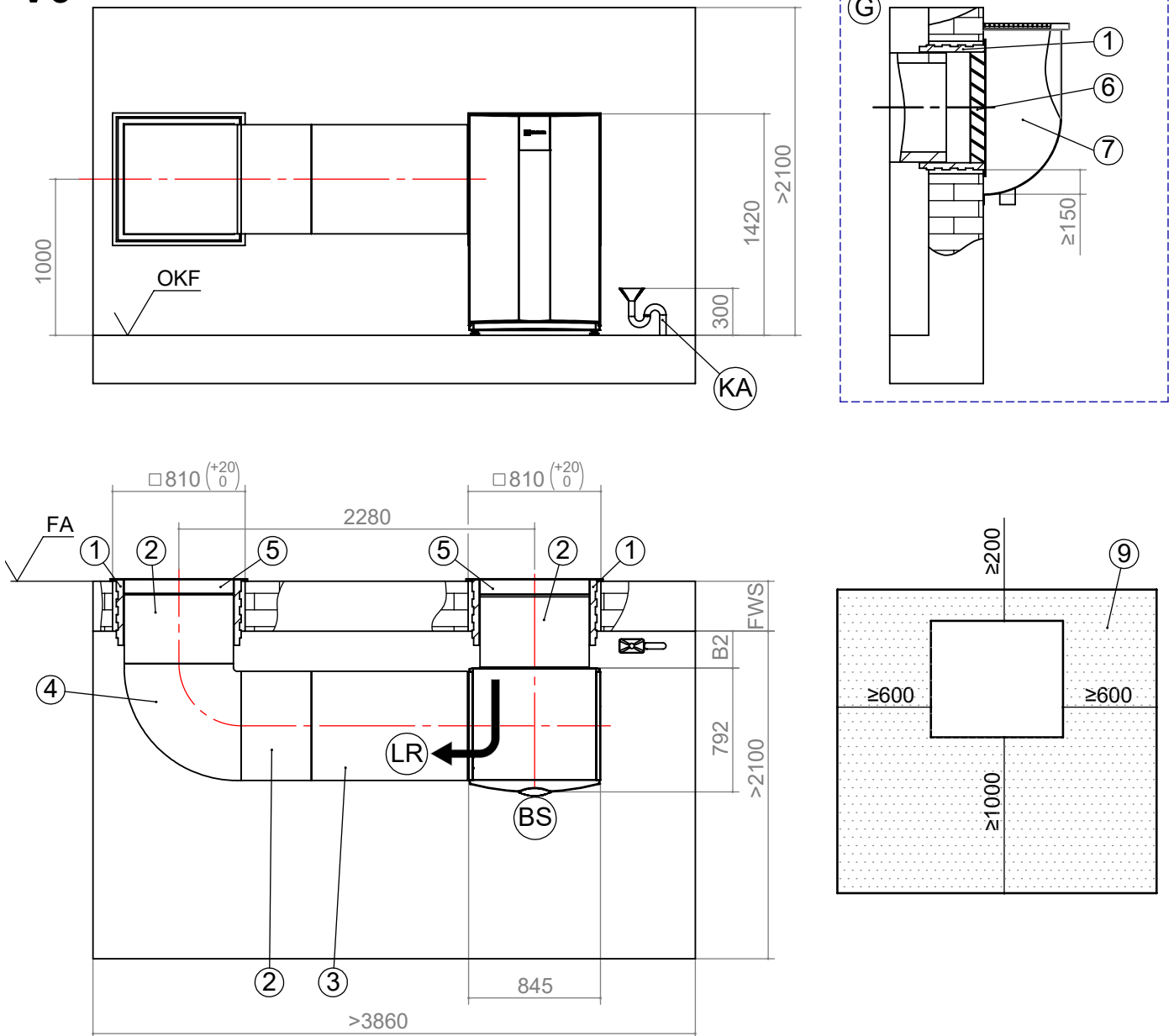

Pos.	Name	Dim.
B2	If finished wall thickness 240 to 320	355
	If finished wall thickness 320 to 400	275
1	Accessory: Wall duct 800x800x420	
2	Accessory: Air duct 700x700x450	
3	Accessory: Air duct 700x700x1000	
4	Accessory: Air duct bend 700x700x750	
5	<b>Installation above ground level</b> Accessory: Weather protection grid 845x850	
6	<b>Installation in the light well</b> Accessory: Rain protection grid 845x850	
7	On site: Light well with water drain min. free cross-section 0.6 m <sup>2</sup>	
9	Minimum clearance for service purposes If clearances are reduced to the minimum dimension, the air ducts must be shortened. This causes a substantial increase in the sound pressure level!	

Keys: UK819471

All dimensions in mm.

V6	Version 6
OKF	Top edge of the finished floor
FA	Finished external façade
LR	Air direction
BS	Control side
FWS	Finished wall thickness
KA	Condensate drain
G	Cut: Installation in the light well



# LWV V7

## Installation plan V7

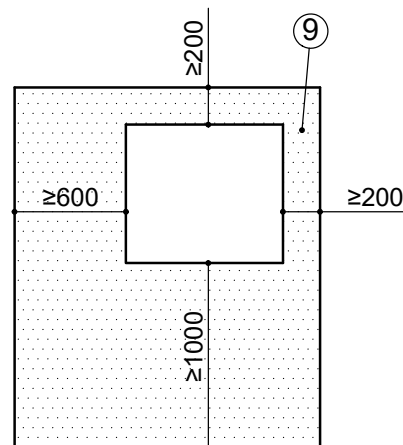
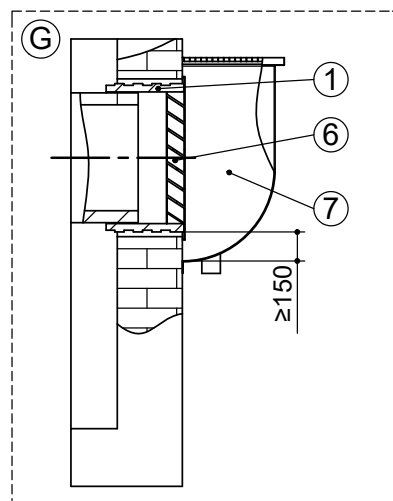
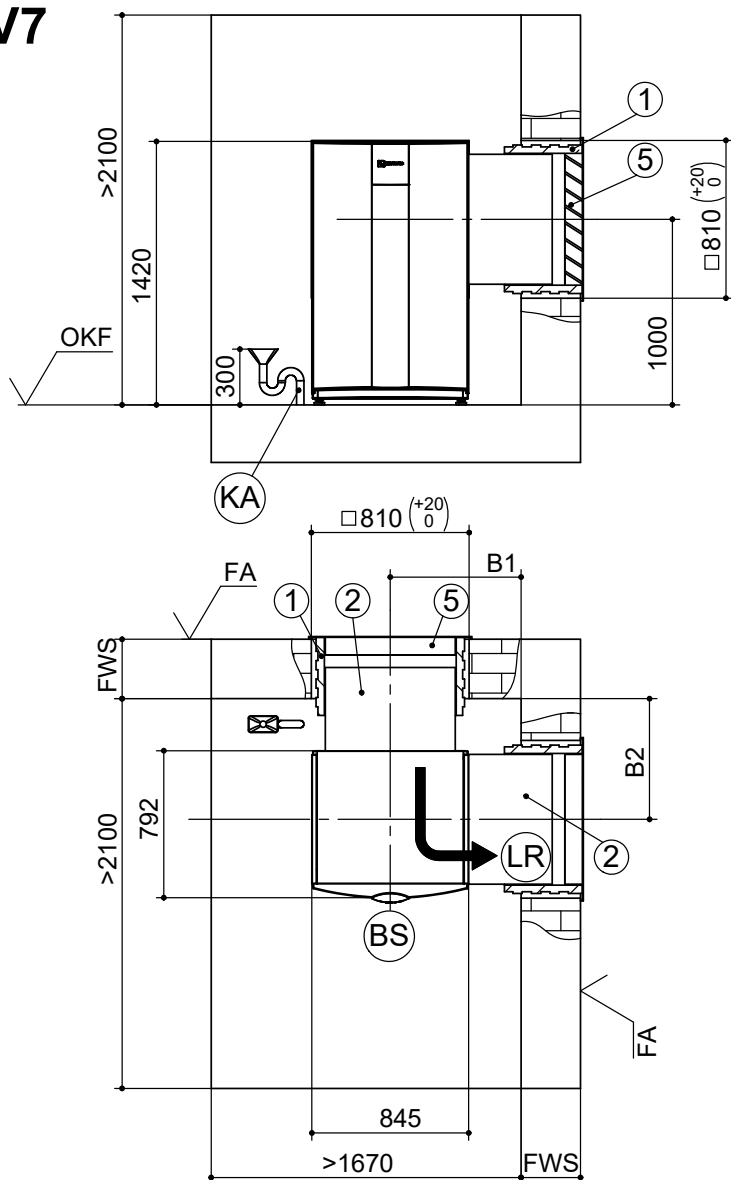

Keys: UK819471

All dimensions in mm.

V7	Version 7
OKF	Top edge of the finished floor
FA	Finished external façade
LR	Air direction
BS	Control side
FWS	Finished wall thickness
KA	Condensate drain
G	Cut: Installation in the light well

Pos.	Name	Dim.
B1	If finished wall thickness 240 to 320	760
	If finished wall thickness 320 to 400	680
B2	If finished wall thickness 240 to 320	730
	If finished wall thickness 320 to 400	650
1	Accessory: Wall duct 800x800x420	
2	Accessory: Air duct 700x700x450	
5	<b>Installation above ground level</b> Accessory: Weather protection grid 845x850	
6	<b>Installation in the light well</b> Accessory: Rain protection grid 845x850	
7	On site: Light well with water drain min. free cross-section 0.6 m <sup>2</sup>	
9	Minimum clearance for service purposes If clearances are reduced to the minimum dimension, the air ducts must be shortened. This causes a substantial increase in the sound pressure level!	

### Space-saving installation

If space-saving installation is chosen, access to the devices is limited on the air outlet side, which restricts the ease of installation and servicing. For more complex service tasks, it may be necessary to remove the device. Higher sound levels are to be expected.



# Installation plan V8

LWV

## V8

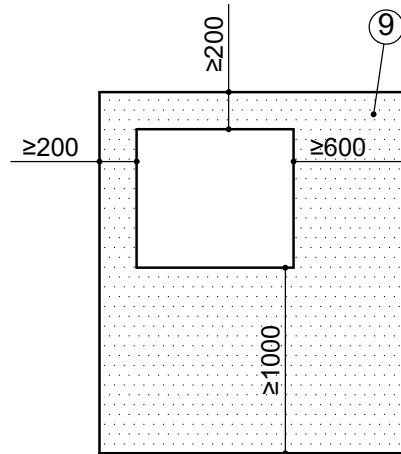
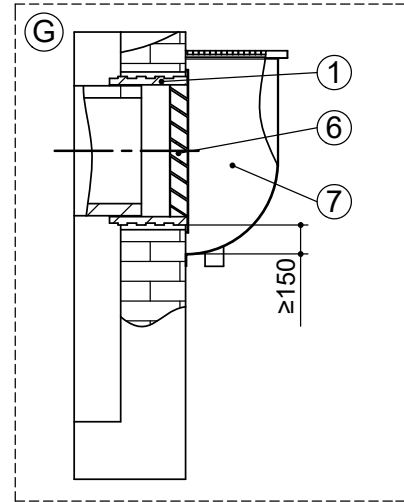
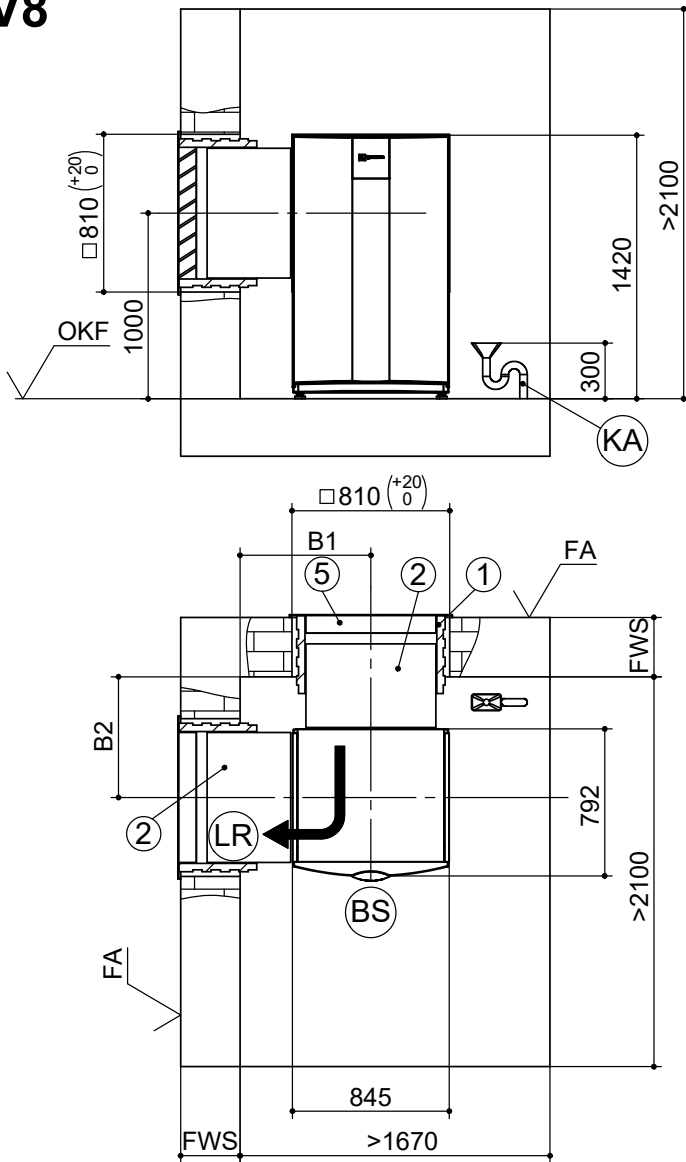

Keys: UK819471

All dimensions in mm.

V8	Version 8
OKF	Top edge of the finished floor
FA	Finished external façade
LR	Air direction
BS	Control side
FWS	Finished wall thickness
KA	Condensate drain
G	Cut: Installation in the light well

Pos.	Name	Dim.
B1	If finished wall thickness 240 to 320	760
	If finished wall thickness 320 to 400	680
B2	If finished wall thickness 240 to 320	730
	If finished wall thickness 320 to 400	650
5	<b>Installation above ground level</b> Accessory: Weather protection grid 845x850	
6	<b>Installation in the light well</b> Accessory: Rain protection grid 845x850	
7	On site: Light well with water drain min. free cross-section 0.6 m <sup>2</sup>	
9	Minimum clearance for service purposes If clearances are reduced to the minimum dimension, the air ducts must be shortened. This causes a substantial increase in the sound pressure level!	

### Space-saving installation

If space-saving installation is chosen, access to the devices is limited on the air outlet side, which restricts the ease of installation and servicing. For more complex service tasks, it may be necessary to remove the device. Higher sound levels are to be expected.



**IMPORTANT**

The minimum distances necessary for correct and safe operation as well as any service work must be observed.

- ✓ Air intake on the side facing away from the coast / from the prevailing wind direction
- ✓ Air outlet not on the side facing the coast / prevailing wind direction

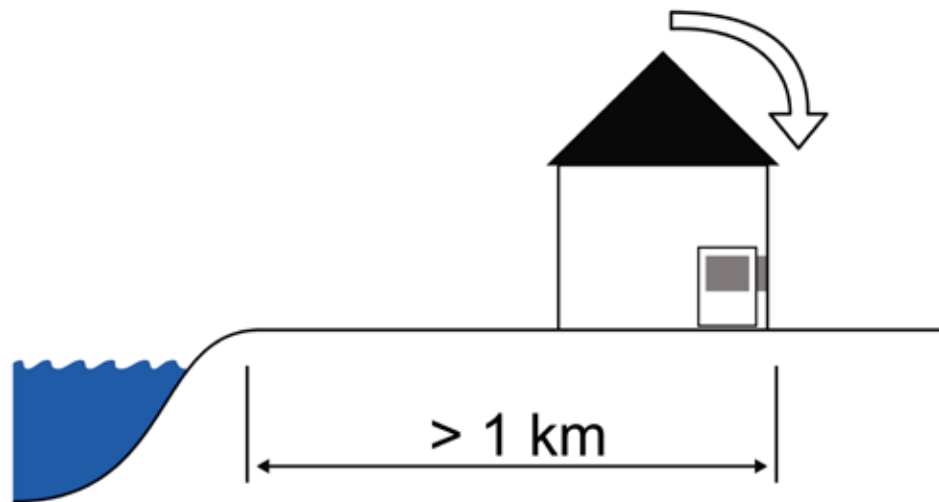



# LWV with hydraulic station

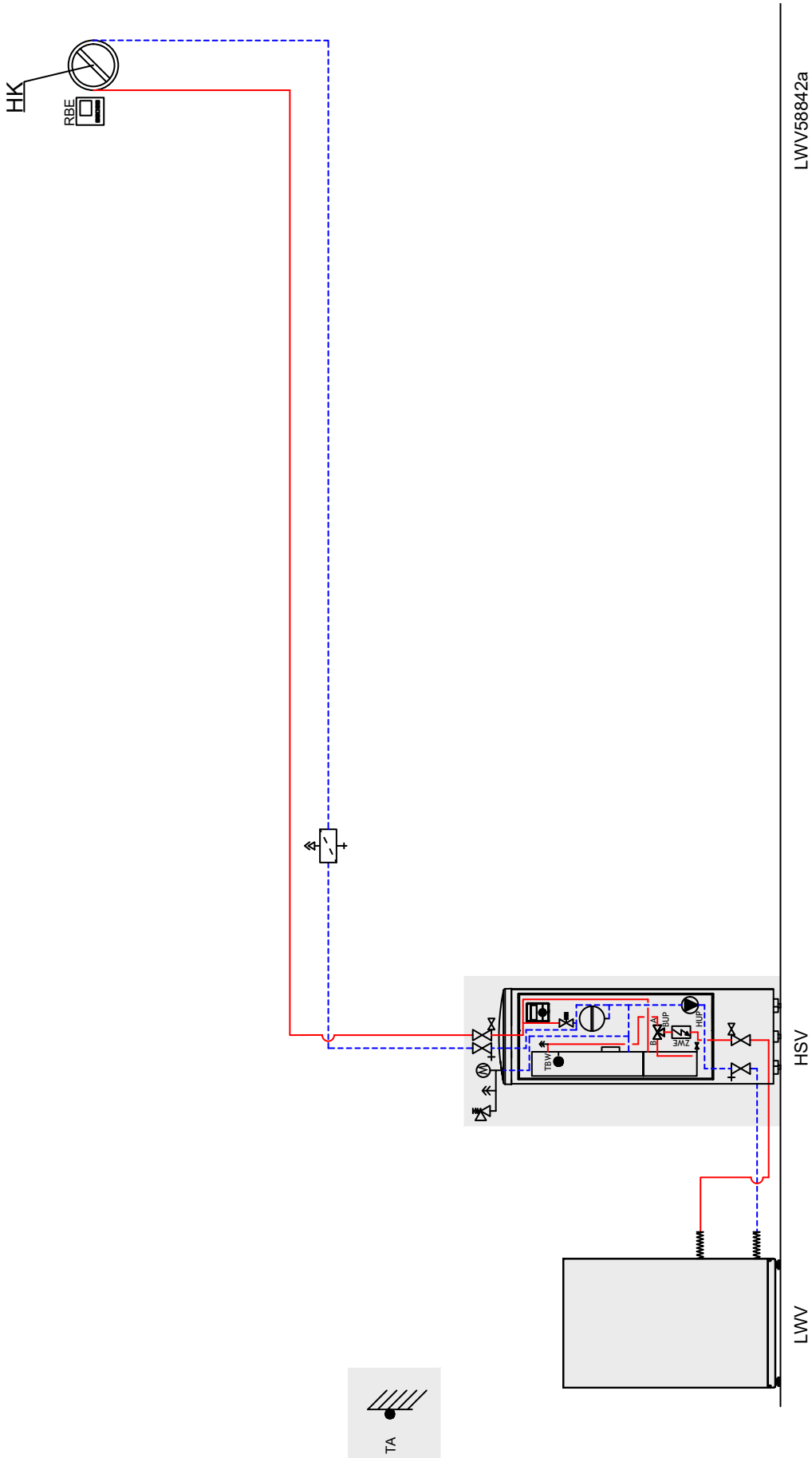

**NOTE** This schematic diagram is an example of a system without shut-off and safety devices, and it does not replace the technical planning and design on site. All regional standards, laws and regulations must be observed. The pipe dimensions must be carefully planned and designed.



# LWV with buffer tank in series and hydraulic module

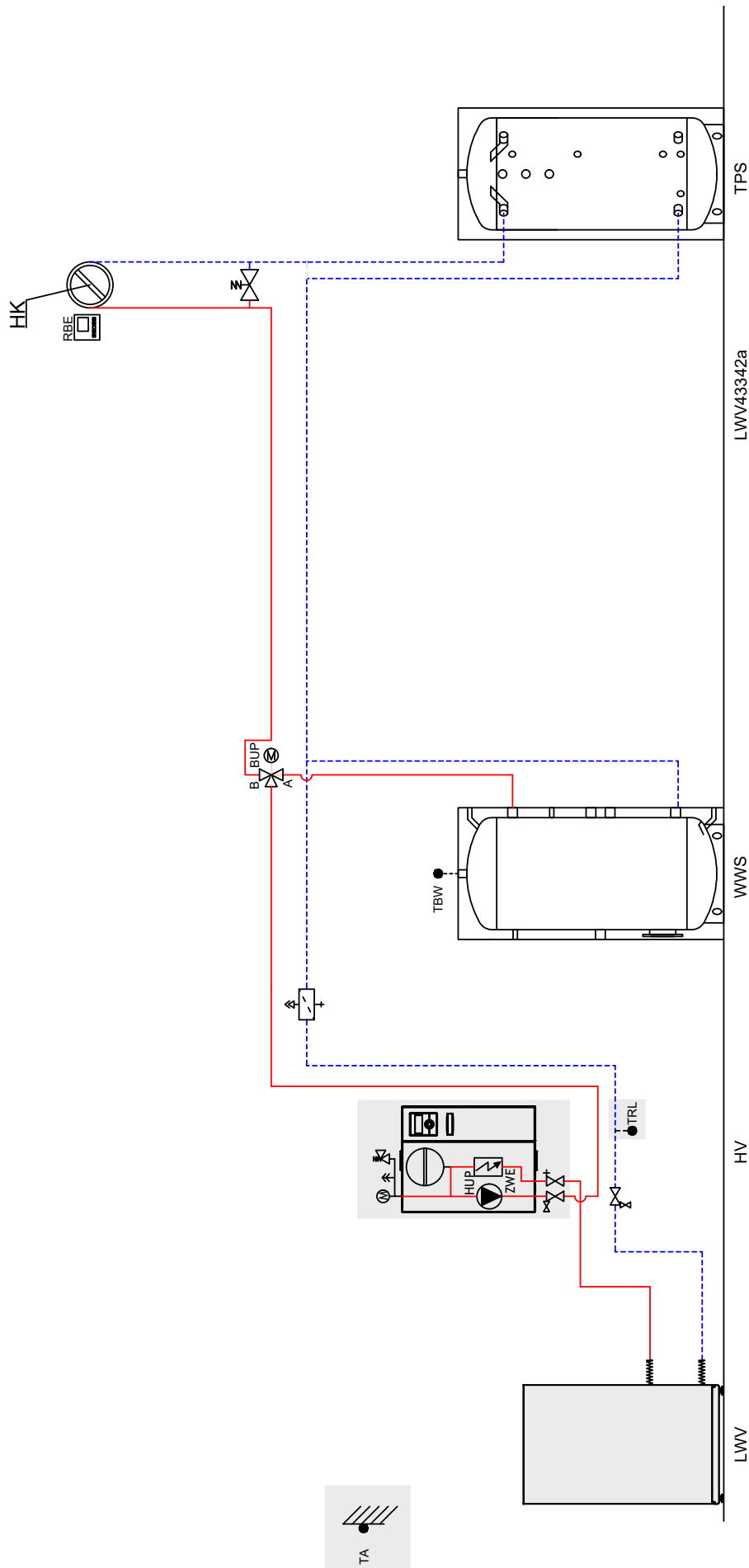

## NOTE

This schematic diagram is an example of a system without shut-off and safety devices, and it does not replace the technical planning and design on site. All regional standards, laws and regulations must be observed. The pipe dimensions must be carefully planned and designed.



# LWV with separation tank

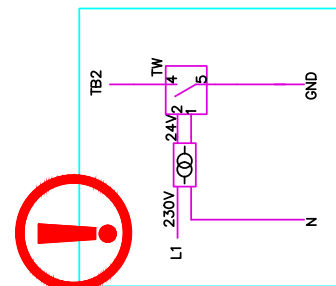
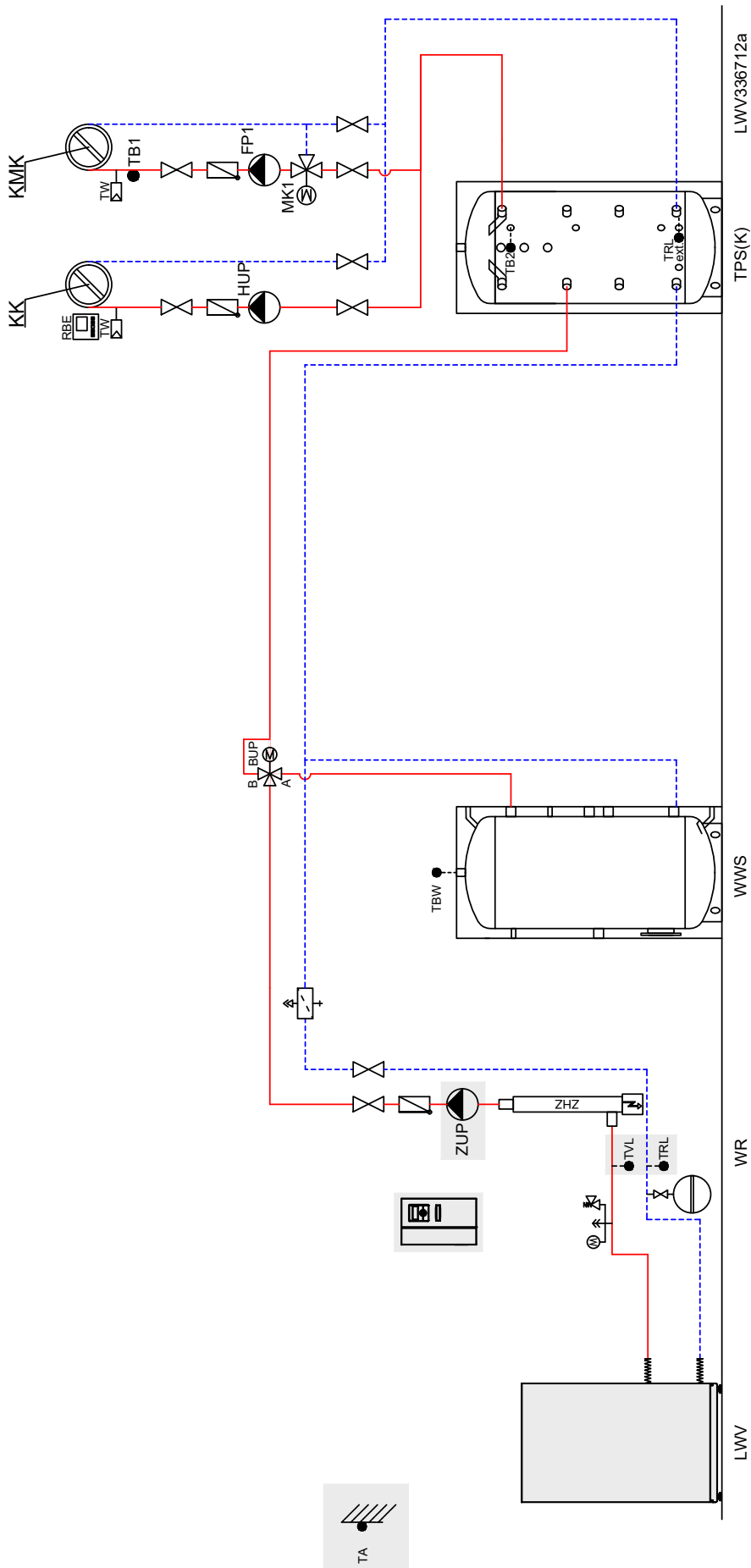

## NOTE

This schematic diagram is an example of a system without shut-off and safety devices, and it does not replace the technical planning and design on site. All regional standards, laws and regulations must be observed. The pipe dimensions must be carefully planned and designed.





	Vibration isolation		Gas- or oil-boiler		Switching valve domestic hot water / heating
	Shut-off device and drainage		Wood boiler		Switching valve cooling / heating
	Shut-off device with dirt trap		Brine pressure switch		Mixing valve additional heating
	Safety group		Swimming pool heat exchanger		Circulation pump
	Shut-off device		Separation heat exchanger / intermediate heat exchanger		Outdoor temperature sensor
	Circulation pump		Solar domestic hot water tank		Sensor return
	Non return valve/ one way valve		Pipe lead-in		Sensor domestic hot water
	Overflow valve		Fresh water station (TWS)		Flow sensor cooling
	Membrane expansion vessel		Room control unit		Temperature sensor, liquid state
	Second heat generator (ZWE)		Dew-point monitor		Flow temperature heating
	3-way mixing valve / switching valve		Supply heat pump		Return temperature heating / cooling
	4-way mixing valve / switching valve		Circulation pump / switching valve domestic hot water		Sensor heating boiler
	Dirt-trap		Mixer circuit 1/2/3 (heating or cooling function)		Room temperature sensor
	Wall breakthrough		Circulation pump heating circuit		Flow heating / cooling
	Brine manifold		Feed circulating pump		Cold water
	Ground slinkies		Circulation pump		Domestic hot water
	Ground collector		Domestic hot water charging pump		Circulation
	Flow switch		Heat source circulation pump		Liquid refrigerant
	Groundwater spring pump with flow direction groundwater		Outdoor temperature sensor		Gaseous refrigerant
	Buffer tank: - TPS Stratified storage tank - RPS Series buffer tank - TPSK Stratified storage tank (cooling) - WTPSK Stratified storage tank, wall-mounted (cooling)		Sensor domestic hot water		Flow second heat generator
	Multifunction tank		Sensor mixer circuit		Return second heat generator
	Domestic hot water tank		Sensor external return		Terminal second heat generator
	Volume flow meter		Sensor return		Expansion board Split (not included in scope of delivery)
	Heat meter		Flow sensor		
			Sensor desuperheater		
			Heating circuit		
			Heating mixing circuit		
			Cooling circuit		
			Safety package primary		
			Safety package secondary		
			Circulation pump desuperheater		
			Controls supplied by customer		



# Circuit diagram 1/5

# LWV 82R1/3

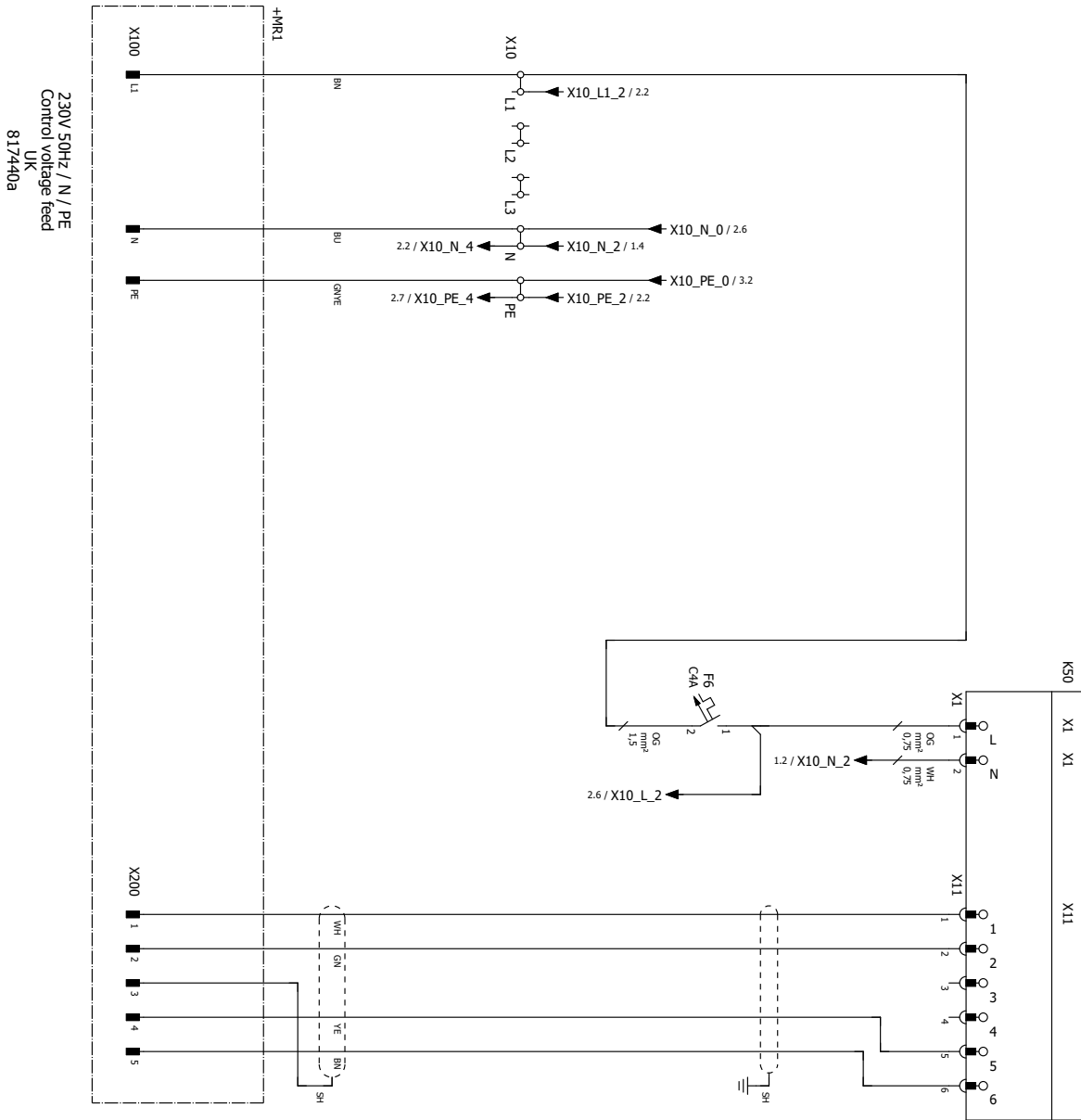

230V 50Hz / N / PE  
Control voltage feed  
UK  
817440a

0	1	2	3	4	5	6	7	8	9
---	---	---	---	---	---	---	---	---	---

Refer to protection notice ISO 16016.



# LWV 82R1/3

# Circuit diagram 2/5

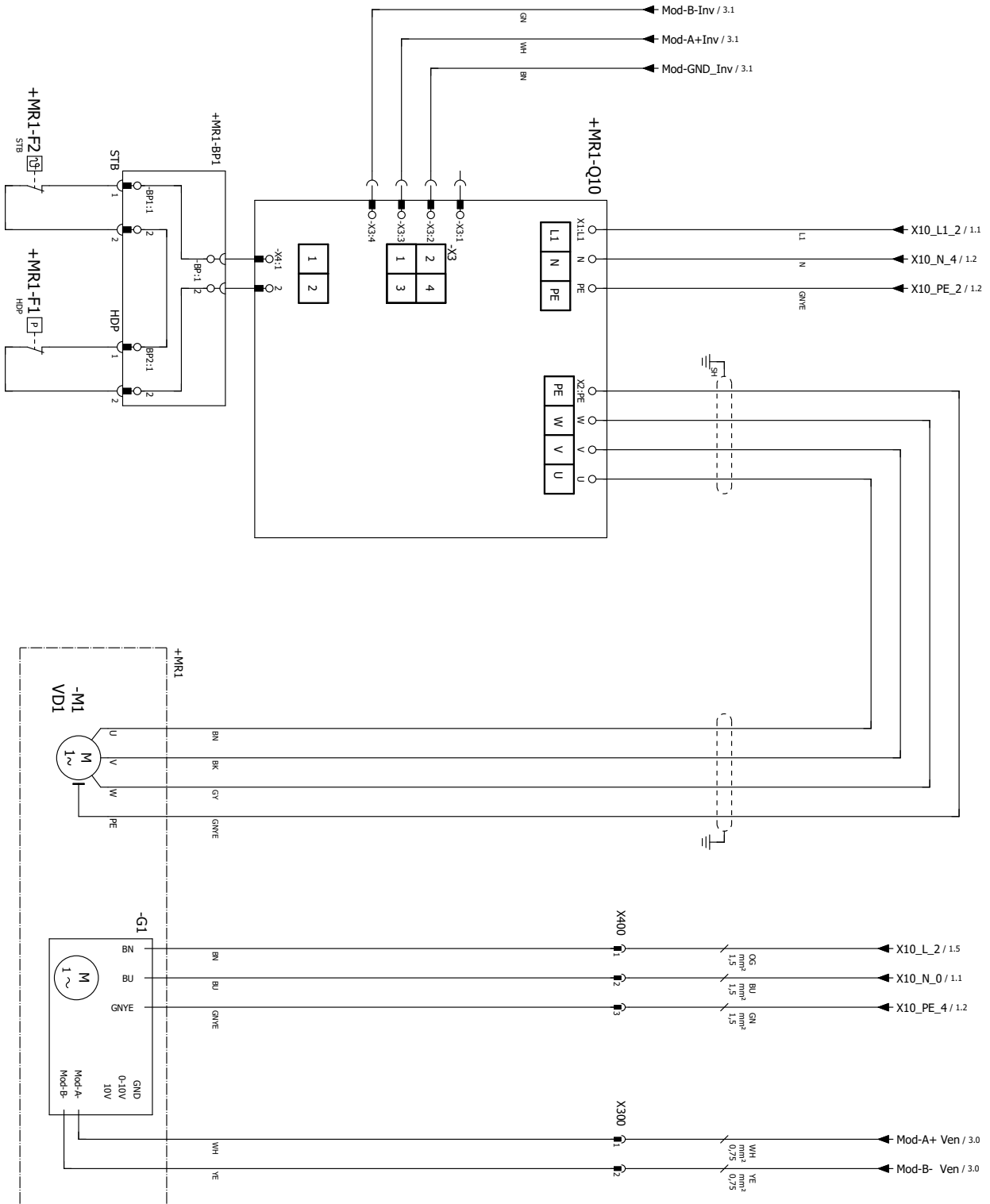

Refer to protection notice ISO 16016.



# Circuit diagram 3/5

# LWV 82R1/3

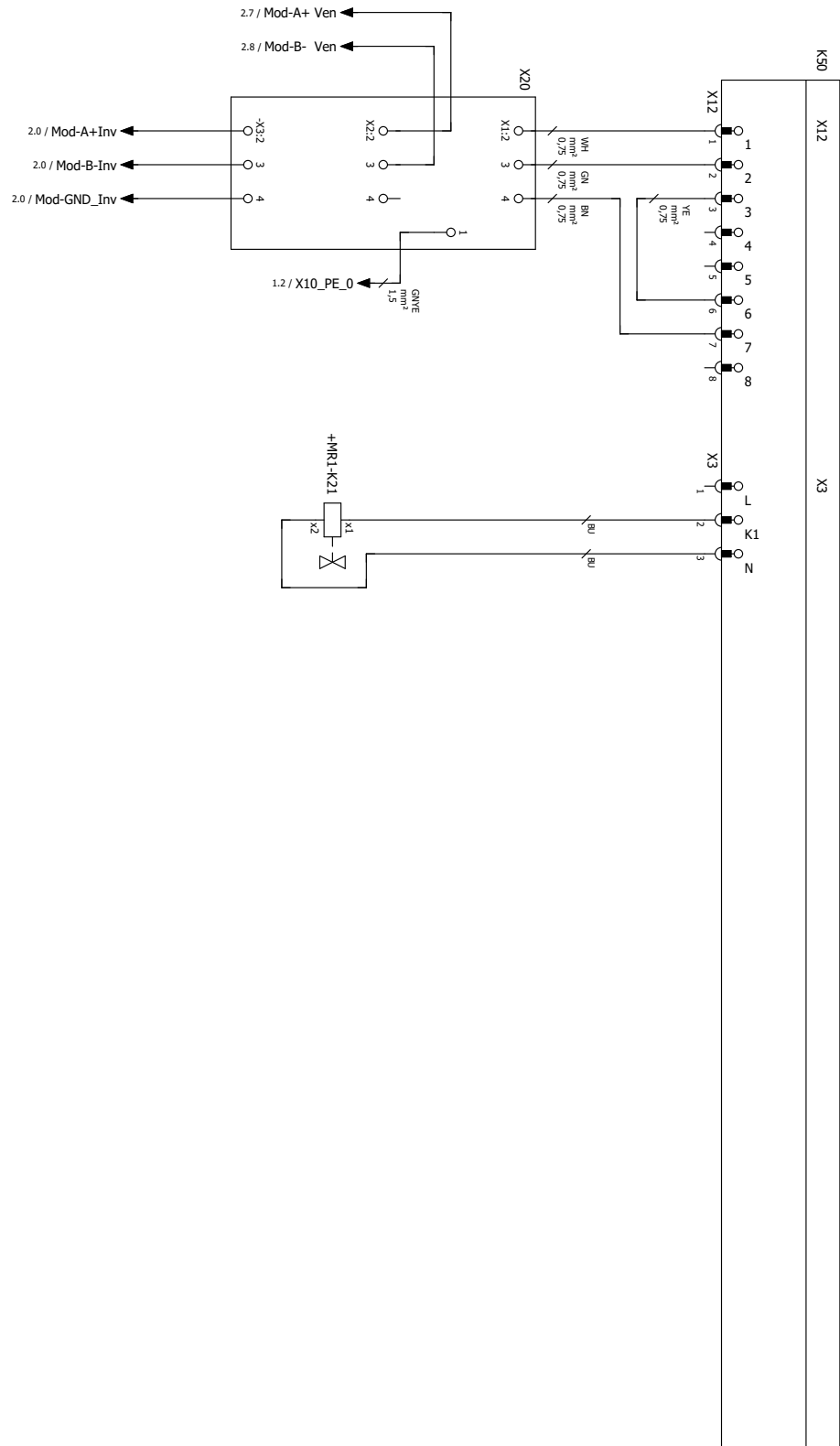

Refer to protection notice ISO 16016.



# LWV 82R1/3

# Circuit diagram 4/5

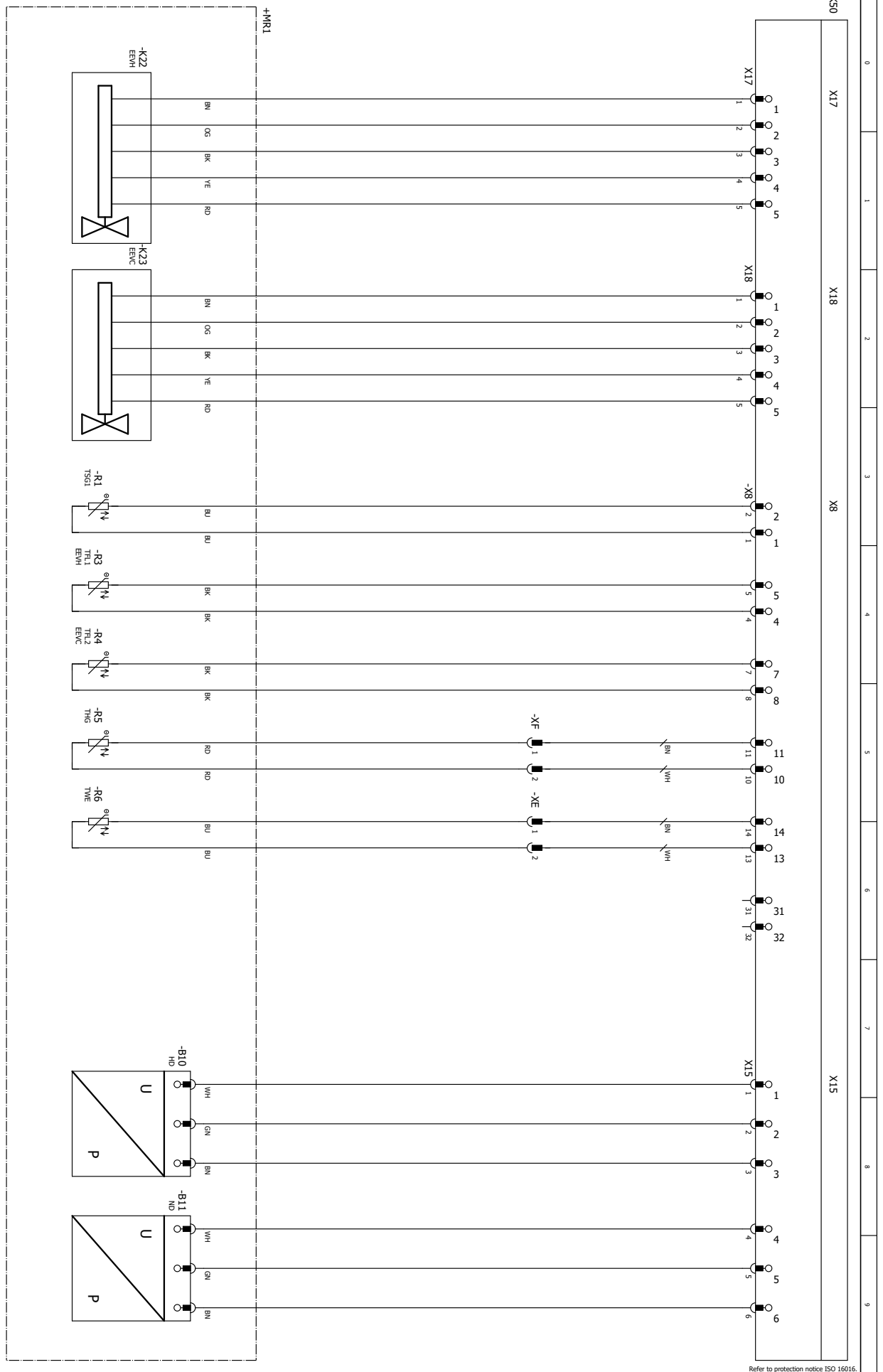

Refer to protection notice ISO 16016.



# Circuit diagram 5/5

# LWV 82R1/3

Equipment	Description
B2	Volumetric flow meter
B10	High-pressure sensor
B11	Low pressure sensor
E20	Compressor heating
F1	High-pressure switch
F2	Temperature switch
F6	Fuses ventilator
G1	Fan
K21	Defrost valve
K22	Electronic expansion valve heating
K23	Electronic expansion valve cooling
K50	ASB board
M1	Compressor
Q10	Inverter
R1	Suction sensor, condenser
R3	Liquid temperature heating
R4	Liquid temperature cooling
R5	Hot gas sensor
R6	Heat source input sensor
RF1	Mains filter
X10	Distribution box power supply output compressor
X20	MODBUS circuit board
X200	Control connector
XSH	Shield clamp Control unit
XE / XF	Plug connector
+MR1	Machine room

Refer to protection notice ISO 16016.



# LWV 122R3

# Circuit diagram 1/5

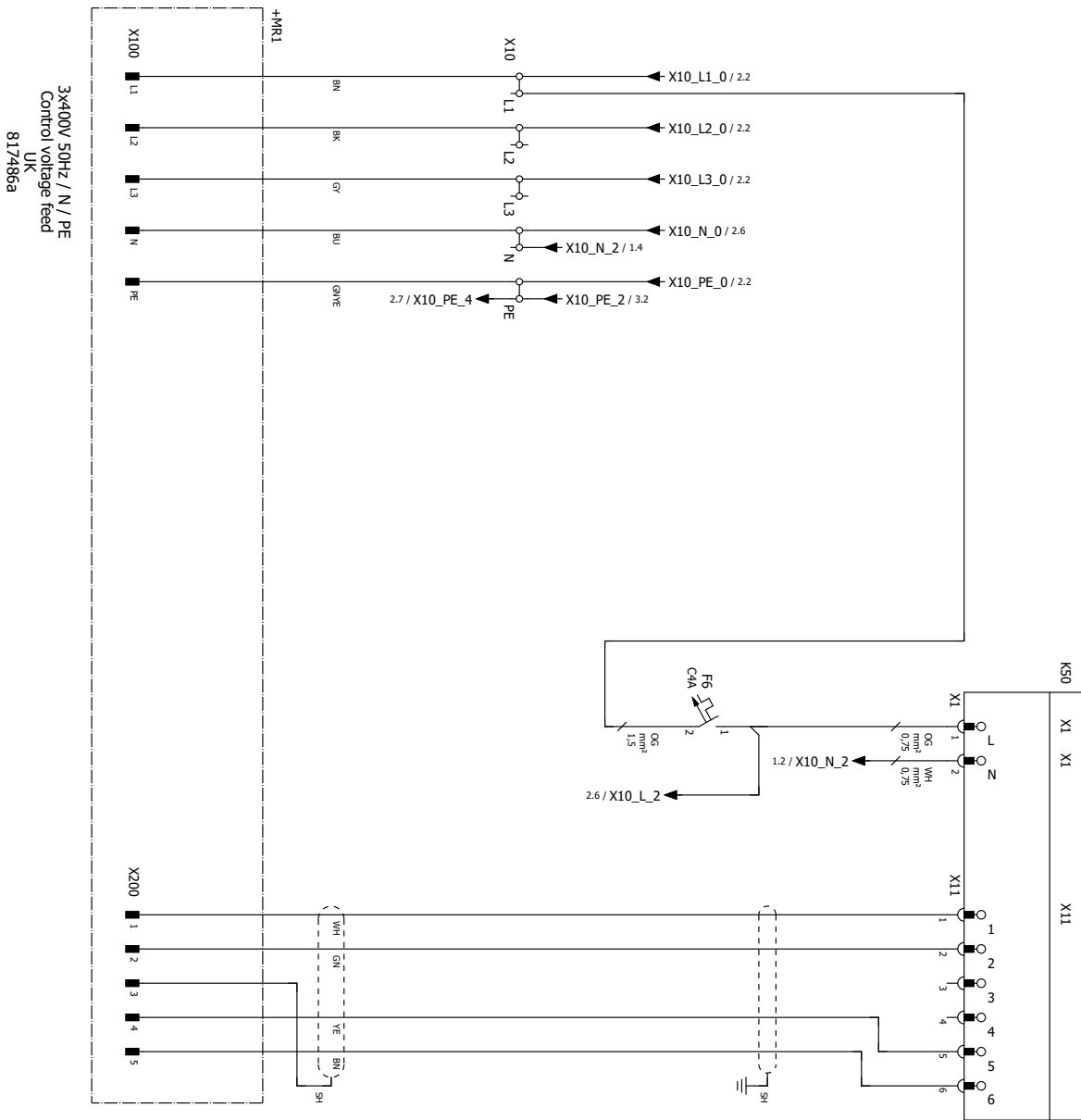

0
1
2
3
4
5
6
7
8
9

Refer to protection notice ISO 16016.



# Circuit diagram 2/5

# LWV 122R3

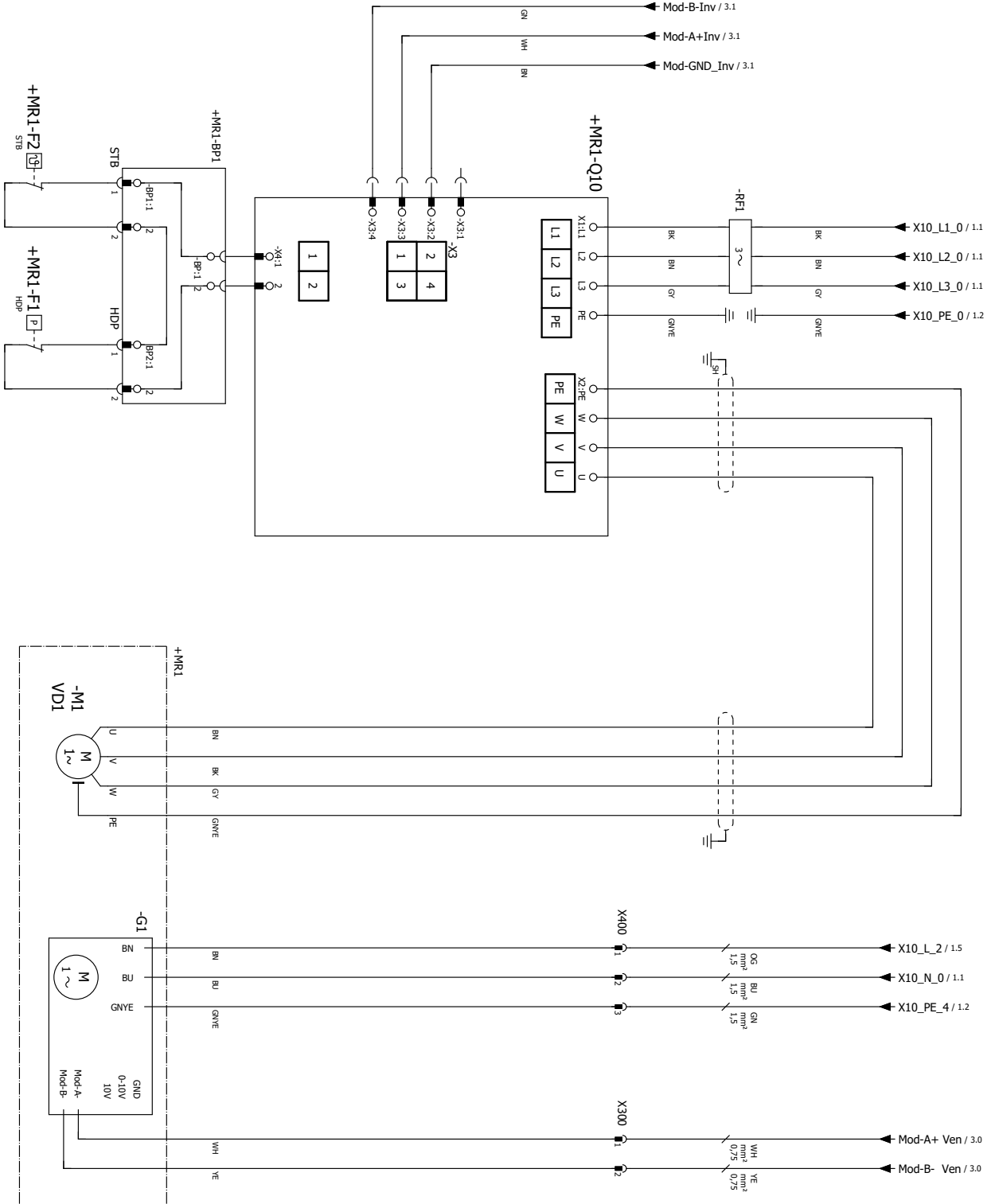

0
1
2
3
4
5
6
7
8
9

Refer to protection notice ISO 16016.







# Circuit diagram 4/5

# LWV 122R3

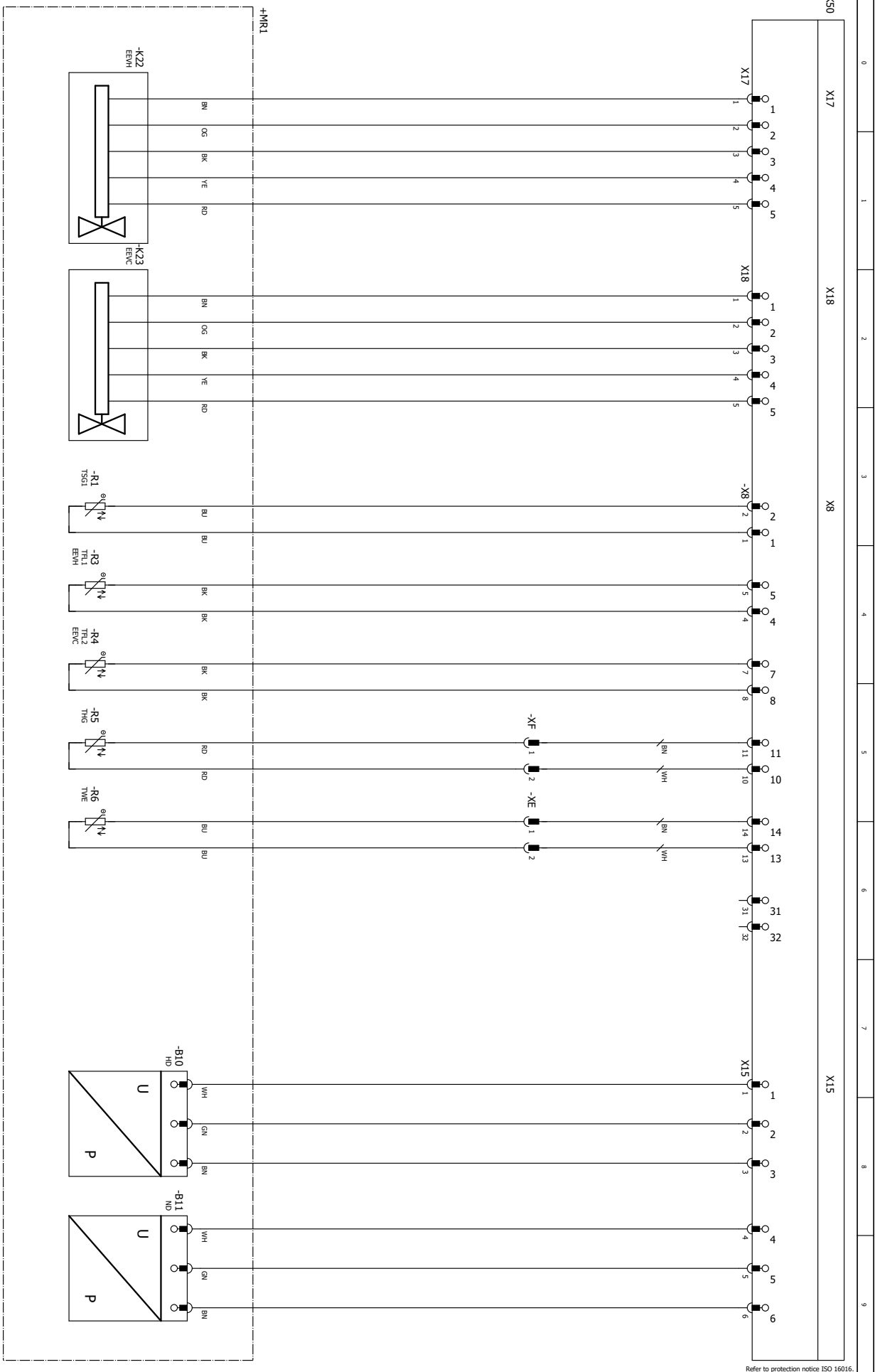

Refer to protection notice ISO 16016.





**alpha innotec**

ait-deutschland GmbH  
Industriestraße 3  
95359 Kasendorf  
Germany

T • +49 9228 / 9906-0  
F • +49 9228 / 9906-189  
E • [info@alpha-innotec.de](mailto:info@alpha-innotec.de)

**[www.alpha-innotec.com](http://www.alpha-innotec.com)**

**alpha innotec** – an ait-deutschland GmbH brand

Subject to technical amendments without prior notice.