

an ideal tomorrow

ait
HEAT PUMPS



Operating Manual

Hydraulic module HV 4 / HV 6H / HV 9H

Accessory for heat pumps

UK

www.aitgroup.com

83071200eUK



Table of contents

1	About this operating manual	3	16	Faults	17
1.1	Validity	3	16.1	Unlock safety temperature limiter	17
1.2	Reference documents	3	17	Dismantling and disposal	17
1.3	Symbols and markings	3	17.1	Dismantling	17
1.4	Contact	4	17.2	Disposal and recycling	17
2	Safety	4	17.2.1	Buffer (standby) battery	17
2.1	Intended use	4	Technical data / Scope of supply	18	
2.2	Personnel qualifications	4	HV 4	18	
2.3	Personal protective equipment	4	HV 6H / HV 9H	19	
2.4	Residual risks	5	HV 4	20	
2.5	Avoid damage to property	5	HV 6H	20	
3	Operation and maintenance	5	HV 9H	20	
3.1	Energy and environmentally-conscious operation	5	Dimensioned drawings	21	
3.2	Maintenance	6	HV 4 / HV 6H	21	
4	Compatible products	6	Drill pattern	21	
5	Scope of supply	6	HV 9H	22	
5.1	Accessories	6	Drill pattern	22	
5.2	Components of the unit	7	Installation plans	23	
6	Storage, transport, installation	7	Terminal diagrams	24	
6.1	Storage	7	HV 4 / HV 6H	24	
6.2	Unpacking and transport	7	HV 9H	26	
6.2.1	Transport with handcart	7	Terminal diagram, mains connection heat pump 1~230V + electric heating element 3~400V	28	
6.2.2	Carrying the unit	7	Terminal diagram, mains connection heat pump 1~230V + electric heating element 1~230V	29	
6.2.3	Unpacking	8	Circuit diagrams	30	
6.3	Installation	8	HV 4 / HV 6H	30	
7	Install the hydraulic connections	10	HV 9H	34	
7.1	Heating circuit	10			
7.2	Expansion vessel	11			
8	Electrical installation	11			
9	Control panel	13			
10	Flushing, filling and venting	14			
10.1	Heating water quality	14			
10.2	Flush and fill the heating circuit and the domestic hot water charging circuit	14			
11	Insulate hydraulic connections	16			
12	Overflow valve	16			
13	Volumetric flow meter / heat meter	16			
14	Commissioning	16			
15	Maintenance	16			
15.1	Maintenance as required	16			
15.2	Yearly maintenance	16			



1 About this operating manual

This operating manual is part of the unit.

- ▶ Before working on or with the unit, read the operating manual carefully and follow it for all activities at all times, especially the warnings and safety instructions.
- ▶ Keep the operating manual to hand at the unit and pass on to the new owner if the unit changes hands.
- ▶ If you have any questions or anything is unclear, ask the manufacturer's local partner or the factory's customer service.
- ▶ Note and follow all reference documents.

1.1 Validity

This operating manual refers solely to the unit identified by the nameplate (→ "Nameplate", page 7).

1.2 Reference documents

The following documents contain additional information with regard to this operating manual:

- Planning manual hydraulic integration
- Operating manual of the heat pump
- Operating manual of the heating and heat pump controller
- Brief description of the heat pump controller
- Operating manual of the expansion board (accessory)

1.3 Symbols and markings

Identification of warnings

Symbol	Meaning
	Safety-relevant information. Warning of physical injuries.
	Safety-relevant information. Warning of physical injuries. Flammable materials / flammable (primary) refrigerant
	Safety-relevant information. Warning of physical injuries. Flammable materials / flammable (primary) refrigerant

Symbol	Meaning
	Safety-relevant information. Warning of physical injuries. Danger of fatal injury due to electric current.
DANGER	Indicates imminent danger resulting in severe injuries or death.
WARNING	Indicates a potentially dangerous situation, which can result in severe injuries or death.
CAUTION	Indicates a potentially dangerous situation, which can result in moderate or minor injuries.
IMPORTANT	Indicates a potentially dangerous situation, which can result in property damage.

Symbols in the document

Symbol	Meaning
	Information for qualified personnel
	Information for the owner/operator
✓	Requirement for action
▶	Procedural instructions: Single step action prompt
1., 2., 3., ...	Procedural instructions: Numbered step within a multi-step action prompt. Keep to the given order.
	Additional information, e.g. a tip on making work easier, information on standards
→	Reference to further information elsewhere in the operating manual or in another document
•	Listing
	Secure connections against twisting



1.4 Contact

Addresses for purchasing accessories, for service cases or for answers to questions about the unit and this operating manual can be found on the internet and are kept up-to-date:

- www.ait-deutschland.eu

2 Safety

Only use the unit if it is in proper technical condition and only use it as intended, safely and aware of the hazards, and follow this operating manual.

2.1 Intended use

The unit is designed for household use and is solely intended for the following purposes:

- Heating
- Domestic hot water preparation
- ▶ Intended use includes complying with the operating conditions (→ „Technical data / Scope of supply“, from page 18) as well as the operating manual and observing and following the reference documents.
- ▶ When using the local regulations note: laws, standards, guidelines, directives.

All other uses of the unit are not as intended.

2.2 Personnel qualifications

The operating manuals supplied with the product are intended for all users of the product.

The operation of the product via the heating and heat pump control and work on the product which is intended for end customers / operators is suitable for all age groups of persons who are able to understand the activities and the resulting consequences and can carry out the necessary activities.

Children and adults who are not experienced in handling the product and do not understand the necessary activities and the resulting consequences must be instructed and, if necessary, supervised by persons experienced in handling the product and who are responsible for safety.

Children must not play with the product.

The product may only be opened by qualified personnel.

All procedural instructions in this operating manual is solely directed at qualified, skilled personnel.

Only qualified, skilled personnel is able to carry out the work on the unit safely and correctly. Interference by unqualified personnel can cause life-threatening injuries and damage to property.

- ▶ Ensure that the personnel is familiar with the local regulations, especially those on safe and hazard-aware working.
- ▶ Ensure that the personnel are qualified to handle flammable (primary) refrigerant.
- Work on the refrigerating circuit may only be carried out by qualified personnel with appropriate qualifications for refrigeration system installation.
- Work on the electrics and electronics may only be carried out by electrical technicians.
- Any other work on the system may only be carried out by qualified personnel (heating installer, plumbing installer).

During the warranty and guarantee period, service work and repairs may only be carried out by personnel authorised by the manufacturer.

2.3 Personal protective equipment

During transport and work on the unit, there is a risk of cuts due to the sharp edges of the unit.

- ▶ Wear cut-resistant protective gloves.

During transport and work on the unit, there is a risk of foot injuries.

- ▶ Wear safety shoes.

When working on liquid-conveying lines, there is a risk of injury to the eyes due to leakage of liquids.

- ▶ Wear safety goggles.



2.4 Residual risks

Injuries caused by electric shock

Components in the unit are energised with life-threatening voltage. Before working on the unit:

- ▶ Disconnect unit from power supply.
- ▶ Secure unit against being switched back on again.

Existing earthing connections within housings or on mounting plates must not be altered. If this should nevertheless be necessary in the course of repair or assembly work:

- ▶ Restore earthing connections to their original condition after completion of the work.

Injuries caused by high temperatures

- ▶ Before working on the unit, let it cool down.

Safety instructions and warning symbols

- ▶ Observe the safety instructions and warning symbols on the packaging and on and in the unit.

2.5 Avoid damage to property

Improper action

Requirements for minimum scale and corrosion damage in hot water heating systems:

- Proper planning, design and commissioning
- Closed system with regard to corrosion
- Integration of an adequately dimensioned pressure maintaining device
- Use of demineralised heating water (VE water) or water corresponding to the VDI 2035 norm
- Regular servicing and maintenance

If a system is not planned, designed, started up and operated in accordance with the given requirements, then there is a risk that the following damage and faults will occur:

- Faults and the failure of components, e.g. pumps, valves
- Internal and external leaks, e.g. from heat exchangers
- Cross-section reduction and blockages in components, e.g. heat exchanger, pipes, pumps
- Material fatigue
- Gas bubbles and gas cushion formation (cavitation)

- Negative effect on heat transfer, e.g. formation of coatings, deposits, and associated noises, e.g. boiling noises, flow noises
- ▶ Note and follow the information in this operating manual for all work on and with the unit.

Unsuitable quality of the fill and make-up water in the heating circuit

The efficiency of the system and the service life of the heat generator and the heating components depend decisively on the quality of the heating water.

If the system is filled with untreated drinking water, calcium and magnesium precipitate as mineral scale. Lime scale deposits form on the heat transfer surfaces of the heating. The efficiency drops and energy costs rise. In extreme cases, the heat exchangers will be damaged.

- ▶ Fill the system with deionised heating water (VE water) or with water corresponding to the VDI 2035 norm only (low-salt operation of the system).

3 Operation and maintenance



NOTE

The unit is operated via the control panel of the heating and heat pump controller (→ operating manual of the heating and heat pump controller).

3.1 Energy and environmentally-conscious operation

The generally accepted requirements for energy-conscious and environmentally-conscious operation of a heating system also apply to use of a heat pump. The most important measures include:

- No unnecessarily high flow temperature
- No unnecessarily high domestic hot water temperature (note and follow local regulations)
- Do not open windows with just a gap or tilt open (continuous ventilation); instead, open wide for a short time (shock ventilation)
- Always ensure that the controller settings are correct



3.2 Maintenance

Wipe down the outside of the unit only using a damp cloth or cloth with mild cleaning product (washing-up liquid, neutral cleaning agent). Never use any harsh, abrasive, acid or chlorine-based cleaning products.

4 Compatible products

HV 4

- Paros
- Polaris

HV 6H / HV 9H

- Hybrox
- Helox

5 Scope of supply

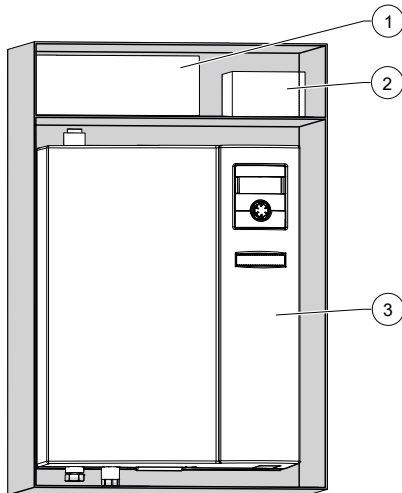

- 1 Accessory package
- 2 Safety module
- 3 Hydraulic module

Accessory package:

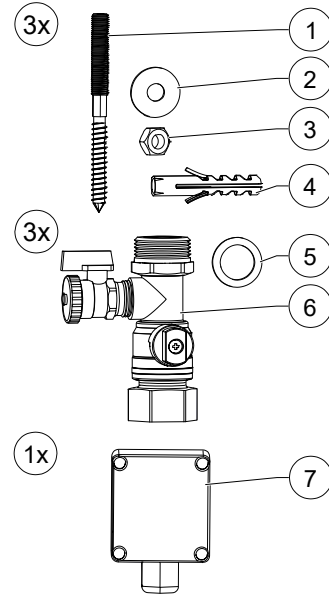

- 1 Hanger bolts (M10) for wall mounting
- 2 Washers for wall mounting
- 3 Nuts (M10) for wall mounting
- 4 Plugs for wall mounting
- 5 Flat seals 1"
- 6 Ball valves
- 7 Outdoor sensor

1. Inspect the delivery for outwardly visible signs of damage.
2. Inspect the scope of supply for completeness. Any defects or incorrect deliveries must be reported immediately.

5.1 Accessories

The following accessories are available for the unit through the manufacturer's local partner:

- Expansion board with various additional functions
- Room control unit for controlling the main functions from the living room
- Electrical connection kit EVS or EVS 8
- Domestic hot water tank
- Buffer tank



5.2 Components of the unit

Example HV 4:

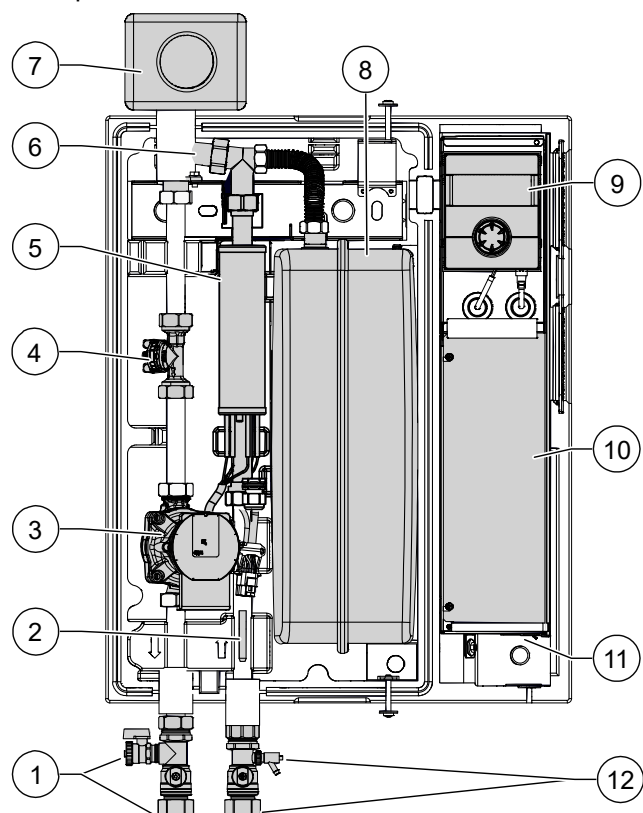

- 1 Heating water outlet (supply): shut-off ball valve with filling and drain tap*)
- 2 Supply sensor
- 3 Energy-efficient circulating pump heating circuit
- 4 Volumetric flow meter
- 5 Electric heating element
- 6 Air separator
- 7 Heating circuit safety module (insulated)*)
- 8 Expansion vessel
- 9 Control panel
- 10 Electrical switch box
- 11 Sockets for the electrical connection kit EVS or EVS 8
- 12 Heating water inlet (supply): shut-off ball valve with drain tap*)
(HV 9H with fill and drain tap)

*) to be mounted at the installation location

Nameplate

A nameplate is attached to the outside of the unit at the factory.

The nameplate contains the following information at the very top:

- Model, item number
- Serial number

The nameplate also contains an overview of the most important technical data.

6 Storage, transport, installation

6.1 Storage

- ▶ Store unit protected against:
 - Moisture/damp
 - Frost
 - Dust and dirt

6.2 Unpacking and transport

Notes on safe transport

The unit is heavy (refer to „Technical data / Scope of supply“, from page 18). There is a risk of injuries or damage to property if the unit falls down or overturns.

The hydraulic connections are not designed for mechanical loads.

- ▶ Do not lift or transport the unit by the hydraulic connections.
- ▶ Transport the unit preferably with a handcart or by carrying.



NOTE

To prevent damage during transport, always transport the unit to final installation location in its original packaging.

6.2.1 Transport with handcart

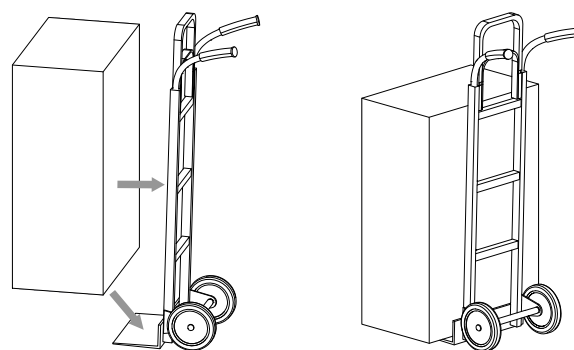

6.2.2 Carrying the unit

- ▶ Carry the packed unit with 2 persons to the installation location.



6.2.3 Unpacking

1. Remove plastic films and cardboard. Ensure that you do not damage the unit.
2. Dispose of the transport and packaging material in an environmentally friendly way and in accordance with local regulations.

6.3 Installation

Installation location

IMPORTANT

Install the unit inside buildings only.

The installation area must be frost-free and dry. It must fulfil the relevant local regulations.

Observe safety and service clearances.

→ "Installation plans", page 23 and „Dimensioned drawings“, from page 21

Mount the unit

Example of installation:

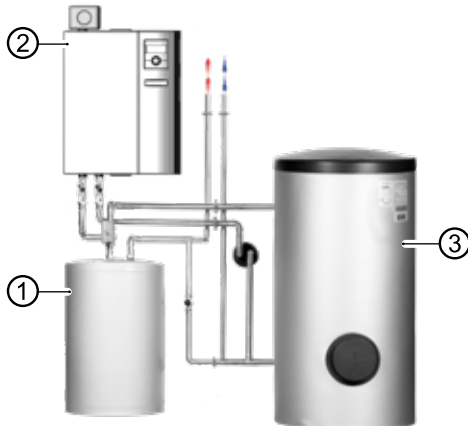

- 1 Buffer tank
- 2 Hydraulic module
- 3 Domestic hot water tank

IMPORTANT

The load-bearing capacity of the wall must be guaranteed.

1. Align drill pattern, mark drill holes and drill. Observe the instructions on the drill pattern.

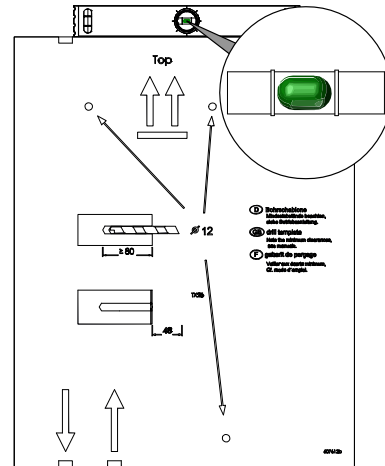

2. Insert the plugs and hanger bolts supplied into the holes drilled.

The plugs supplied are only suitable for use with the following types of walls:

- Concrete
- Solid lightweight concrete blocks
- Cavity block made of lightweight concrete
- Cellular concrete
- Prestressed concrete - hollow ceiling/floor slabs
- Natural stone with dense, close-grained micro-structure
- Solid calcium silicate blocks
- Perforated calcium silicate blocks
- Solid bricks
- Vertically perforated (honeycomb) bricks
- Hollow floors/ceilings made of clay bricks, concrete or similar
- Solid gypsum boards
- Gypsum boards and gypsum fibre boards
- Particle boards

The board material must be dimensioned with sufficient thickness to ensure secure fixing.

Appropriate fixing material must be provided on site for other types of wall constructions.



3. Take off the front hood.

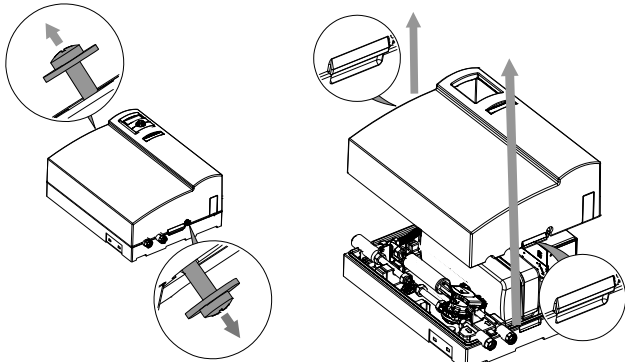

IMPORTANT

The unit must neither be lifted up nor transported by the switch box.

Example HV 4:

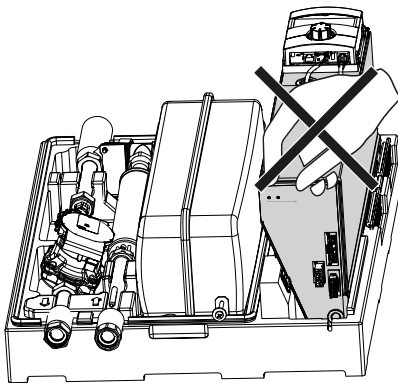

4. Mount the unit to the wall.

Example HV 4:

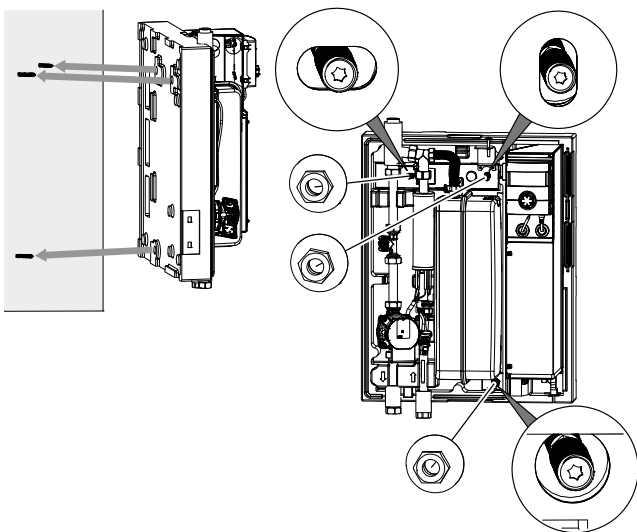

IMPORTANT

The gap between the unit and the wall helps back ventilation. It may not be sealed or closed off.

5. Lay cable glands at a distance of at least 2 cm from the unit.
6. Remount the front hood immediately or after completing the installation work on the rear panel.
- 6.1. On the inside of the front hood, there is a circumferential groove (①). Lock the front hood to the groove in the tongue (②) on the rear panel.

Example HV 4:

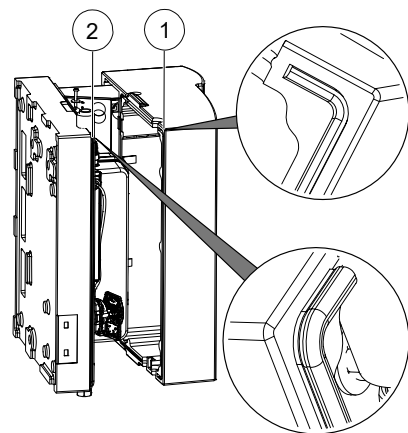

6.2. Screw on the front hood.



7 Install the hydraulic connections



NOTE

The safety valve that is integrated or included in delivery has a tolerance of plus / minus 10% for the set pressure. If local regulations, laws, standards or directives require a smaller tolerance range, the safety valve must be replaced on site with a safety valve that meets the requirements.

IMPORTANT

Avoid open heating systems and / or heating systems that are not oxygen diffusion-tight. If this is not possible, a system separation must be installed.

Depending on the dimensioning of the heat exchanger and the additionally required circulation pump, the system separation worsens the energy efficiency of the system.

IMPORTANT

Dirt and deposits in the (existing) hydraulic system can cause damage to the heat pump.

- ▶ Ensure that a air / magnetic sludge separator is installed in the heating circuit.
- ▶ Rinse the hydraulic system thoroughly prior to establishing the hydraulic connection of the heat pump.

IMPORTANT

Damage to the copper pipes due to unacceptable loading!

- ▶ Secure all connections against twisting.
 - ✓ Cross-sections and lengths of the pipes for the heating circuit are adequately dimensioned. In doing so, always take the connection pipework between the heat pump and hydraulic module into account.
 - ✓ The free pressing of the circulation pumps in the heating circuit at least results in the throughput required for the device type (refer to "Free pressing", page 20)
1. Route all hydraulic connections as fixed piping and attach them via a fixed point to the wall or ceiling at a maximum distance of 20 cm from the centre of the respective unit connection.
 2. Insert a vent at the highest point of the heating circuit.

7.1 Heating circuit

Safety module and shut-off ball valves

1. Take the safety module and the shut-off ball valves out of the accessory pack and fit them to the connections provided. Use seals from the accessory pack.

Example HV 4:

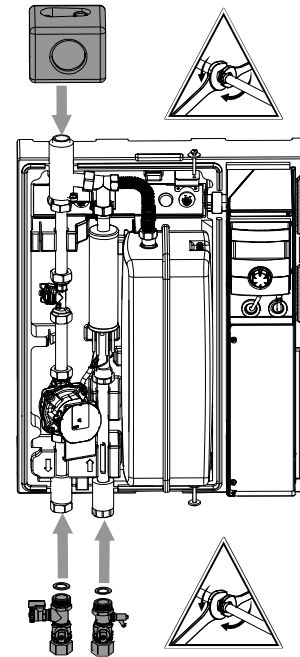

2. Lay the safety discharge of the safety valve into the drain via a funnel waste trap according to the relevant standards and guidelines. It is essential that the safety discharge is connected.

Heating water inlet and outlet

1. Establish hydraulic connection to the unit.
2. Establish hydraulic connection to the heating circuit / domestic hot water tank.

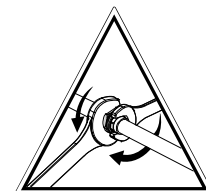

- Position of the connections: „Dimensioned drawings“, from page 21



7.2 Expansion vessel

The expansion vessel for the heating circuit is integrated. Always check whether the size of the expansion vessel is large enough for the system. If necessary, an additional expansion vessel must be installed on site in accordance with the relevant standards and guidelines.



NOTE

The admission pressure of the expansion vessel must be adjusted to the system (approx. 0.5 bar less than the system filling pressure) in accordance with the calculation to the relevant standards (EN 12828).

8 Electrical installation

8.1 Establish electrical connections

IMPORTANT

Irreparable damage to the compressor due to wrong rotating field (only applies to units with 400V connection).

- ▶ Ensure that there is a clockwise rotating field for the compressor load infeed.

Basic information on the electrical connection

- The specifications of the local energy supply company may apply to electrical connections
- Fit the power supply for the heat pump with an all-pole circuit breaker with at least 3 mm contact spacing (per IEC 60947-2)
- Note the level of the tripping current (→ „Technical data / Scope of supply“, from page 18)
- Comply with the electromagnetic compatibility regulations (EMC regulations)
- Lay unshielded power supply cables and shielded cables (bus cable) sufficiently far apart (> 100 mm)
- Maximum line length: 30m

Establish the electrical connections between the heat pump and the hydraulic module

→ Operating manual of the heat pump

8.2 Electrical connection

The electrical connection is established via the switch box.

The hydraulic module is connected electrically on site according to the following scheme:

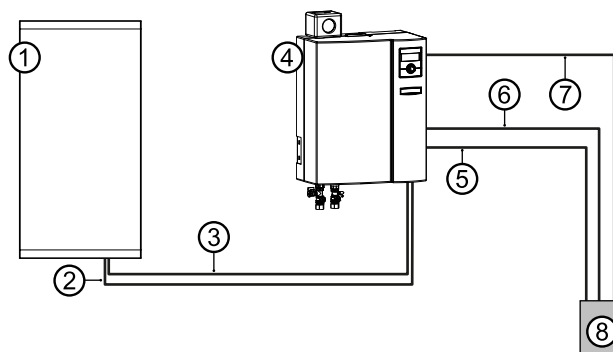

- 1 Heat pump
- 2 Load cable compressor
(accessory: electrical connection kit EVS or EVS 8)
- 3 Bus cable (shielded)
(accessory: electrical connection kit EVS or EVS 8)
- 4 Hydraulic module
- 5 Load line electric heating element
- 6 Control voltage
- 7 Load cable compressor
- 8 Sub-distribution

1. Open the side cover (①) of the electrical switch box.

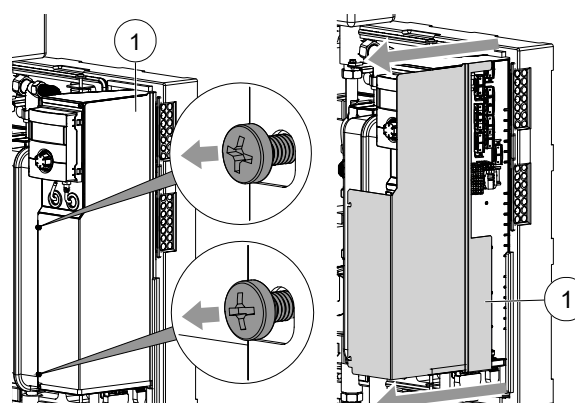



2. Fasten the return sensor (②) to the heat-conducting pipe of the return line leading to the heat pump (③) using cable ties and thermal compound.

Example HV 4:

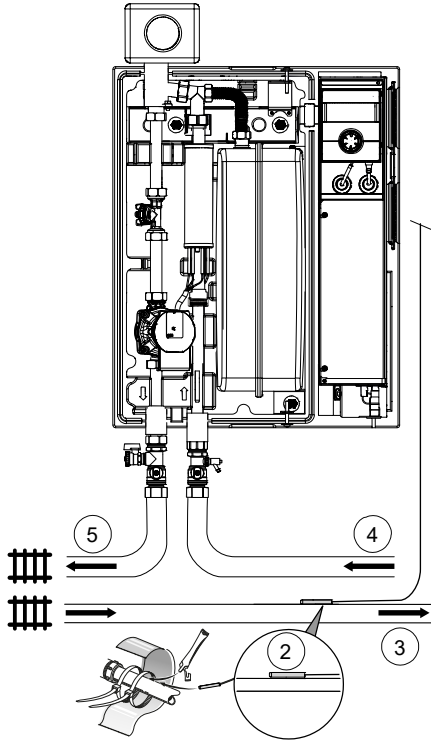

- 2 Return sensor on hydraulic module
 - 3 Return to heat pump
 - 4 Supply from heat pump
 - 5 Supply to heating circuit / domestic hot water tank
3. Lay the sensor cable to the hydraulic module.
 4. Strip the control and sensor cable, of the cable for the EVU blocking time as well as the cables of external loads before feeding them into the switch box (stripping length of each of the individual wires: 6 mm).
 5. Feed the cables through the cable gommets (⑥) into the switch box.

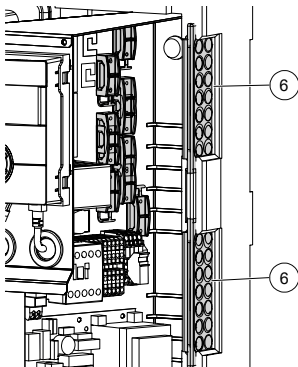

6. Fit the connectors to the bus cable and power cable of the heat pump.

→ Operating manual of the heat pump

7. Insert the wired plugs of the heat pump power cable (⑦) and the bus cable (⑧) into the corresponding socket at the bottom of the electrical switch box.

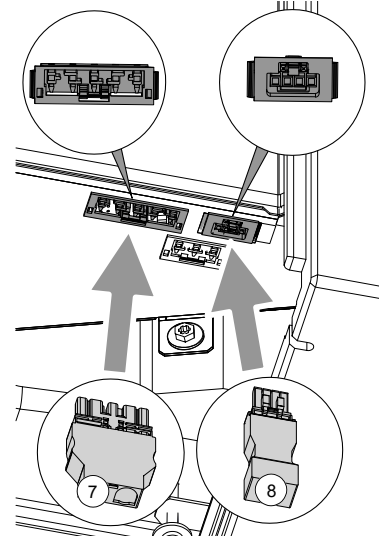

8. Make further electrical connections in accordance with the terminal diagram.
- „Terminal diagrams“, from page 24
9. Insert all cables introduced into the switch box into the cable ducts in the switch box, route them through the strain reliefs (⑨) and screw them into the strain reliefs.

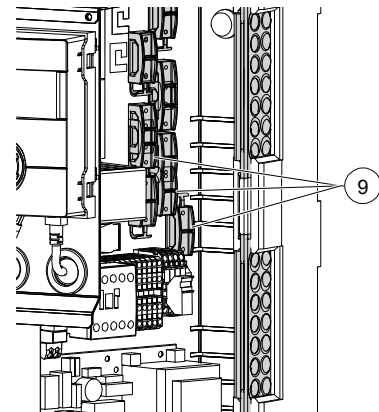

NOTE

The control panel of the heating and heat pump controller can be connected to a computer or network using a suitable network cable, enabling the heating and heat pump controller to be controlled remotely from there.



If such a connection is desired, route a shielded network cable (⑩, category 6, with RJ45 connector) through the electrical switch box and plug it to the corresponding socket of the control panel.

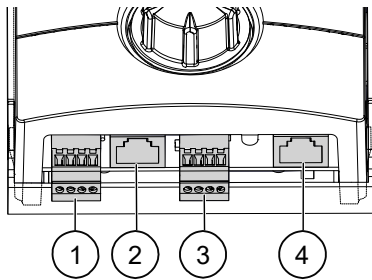
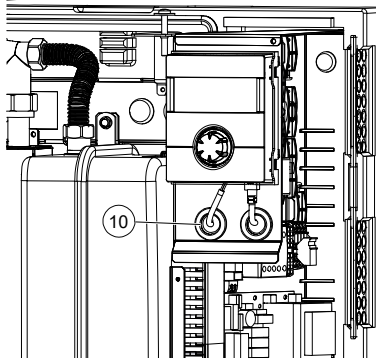

- 1 RS485 for connecting the room control unit RBE (accessory)
- 2 RJ45 for network cable connection
- 3 RS485 LIN bus cable connection to the control board
- 4 RJ45 connection Modbus cable to Modbus distributor.



NOTE

The integrated electric heating element is connected at 9kW (6kW) in the factory. At contactor Q, it is possible to select 6kW (4kW) = 2 phase operation. Disconnect Q5/6 for this. Or 3kW (2kW) = 1 phase operation. Disconnect Q5/6 and Q5/4 for this.

The values in brackets are for the 6kW heating element. Disconnected cables must be furnished with screw terminals. Only the phases cited above may be disconnected (safety temperature limiter).

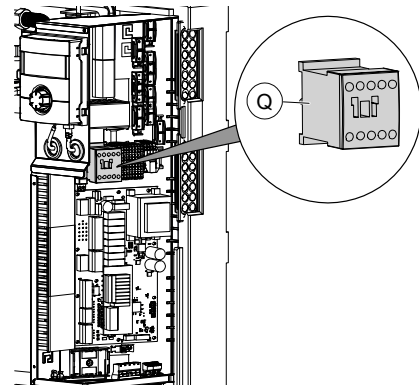

10. Close the electrical switch box by re-attaching the side cover.

9 Control panel

The control panel is pre-assembled at the factory. If the control panel needs to be removed for any reason:

1. Take off the front hood.
2. Disconnect or unplug all connections at the bottom.
3. Lift off the control panel.

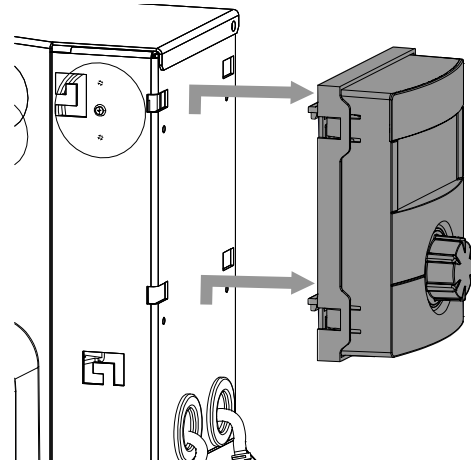

Reattaching the control panel:

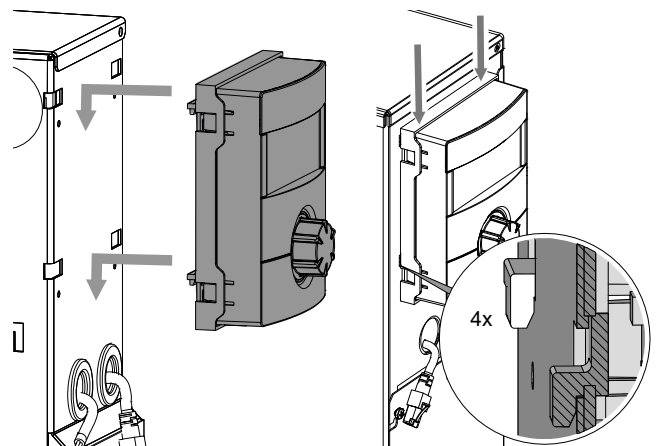



10 Flushing, filling and venting

10.1 Heating water quality



NOTE

For detailed information refer, among other things, to the VDI Guidelines 2035 “Vermeidung von Schäden in Warmwasserheizanlagen” (preventing damage in hot water heating systems).

1. Ensure that the pH-value of the heating water is between 8.2 – 10, for aluminium materials between 8.2 – 9.
Ideally, the pH value should already be in the required range after filling. After 6 weeks at the latest, it must have adjusted to the required range.
2. Ensure that the electrical conductivity is $< 100 \mu\text{S}/\text{cm}$.



NOTE

If the required water quality is not achieved, consult a company specialising in the treatment of heating water.

3. Fill the system with deionised heating water (VE water) or with water corresponding to the VDI 2035 norm only (low-salt operation of the system).
Advantages of low-salt operation:
 - Low corrosion-promoting properties
 - No formation of mineral scale
 - Ideal for closed heating circuits
4. Keep a system log for hot water heating systems in which relevant planning data and the water quality are entered (VDI 2035).

10.2 Flush and fill the heating circuit and the domestic hot water charging circuit

- ✓ Outlet pipe of the safety valve is connected.
- Ensure that the set pressure of the safety valve is not exceeded.

IMPORTANT

Flush the heating circuit only in its flow direction.



NOTE

The venting program on the controller can also be used to support the flushing and venting process. It is possible to control individual circulation pumps and even the changeover valve through the venting programme. As a result it is not necessary to remove the valve motor.

1. Vent the system at the highest point.
2. Pull off the U-clip (①) on the back of the valve motor (②) on the 3-way switching valve (③, accessory) upwards.

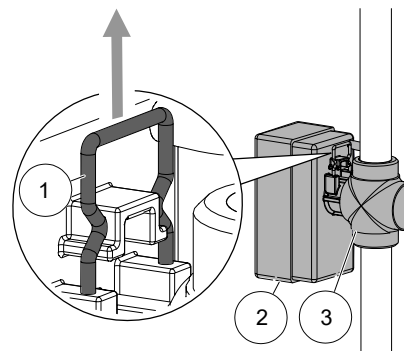

3. Carefully pull the valve motor (②) forward from the 3-way switching valve (③).

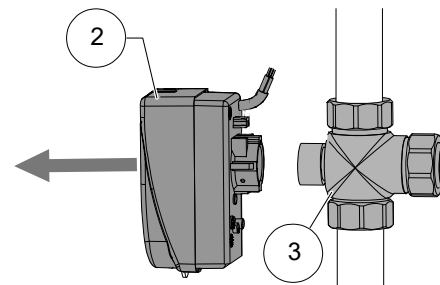

4. Turn the spindle of the 3-way switching valve so that the rounded side of the spindle points in the direction of marking A of the connections of the 3-way switching valve.

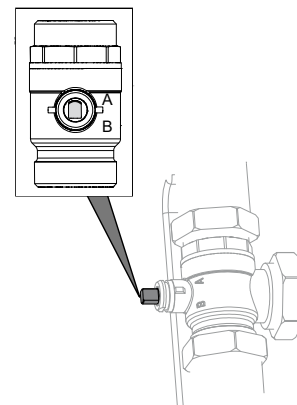



5. Flush the domestic hot water charging circuit for approx. 1 minute.
6. Turn the spindle so that the rounded side of the spindle points in the direction of marking B of the connections of the 3-way switching valve.
7. Flush heating circuit thoroughly, until no more air is discharged.
8. Position the valve motor (2) on the 3-way switching valve (3).

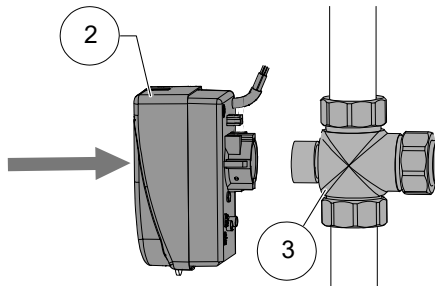

9. Insert the U-clip (1) into the back of the valve motor (2).

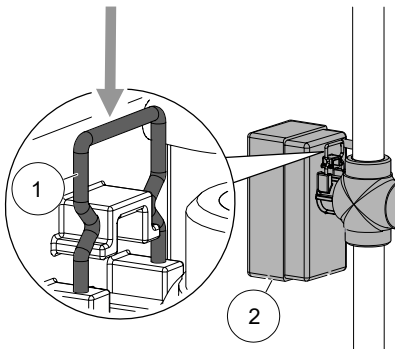

10. Ensure that the U-clip has latched into position correctly:
 - ✓ Valve motor sits securely on the 3-way switching valve.
 - ✓ Both prongs of the U-clip sit on the lug.
 - ✓ The tips of the U-clip are not visible more than approx. 2 mm.

Example for integration of storage tank in series:

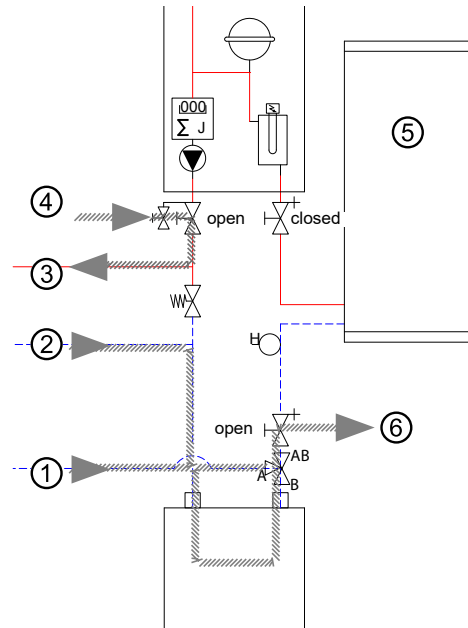

Example for integration of storage tank in series:

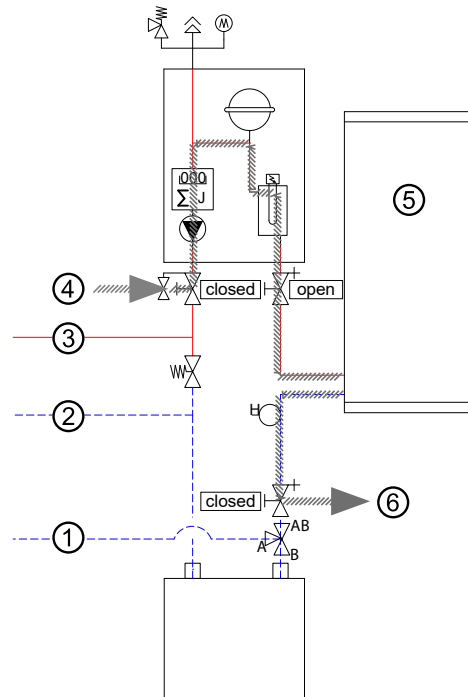

- 1 Return, domestic hot water
- 2 Return, hot heating water
- 3 Supply, hot heating water / domestic hot water
- 4 Filling stop cock
- 5 Heat pump
- 6 Drain

11. Swap the hoses at the filling and draining stop cocks and flush the condenser of the heat pump via the return.



12. Open the additional vent valve at the condenser of the heat pump. Vent the condenser and then close the vent valve again when fully vented.

→ Operating manual of the switching valve

11 Insulate hydraulic connections

Insulate hydraulic lines in accordance with local regulations.

1. Open shut-off devices.
2. Perform a pressure test and inspect for leaks.
3. Insulate external piping on site.
4. Insulate all connections, fittings and pipes.

12 Overflow valve

→ Operating manual of the heat pump

13 Volumetric flow meter / heat meter

The integrated volumetric flow meter / heat meter (①) is used to measure the heat quantity generated by the heating system and made available for domestic hot water preparation and building heating.

Example HV 4:

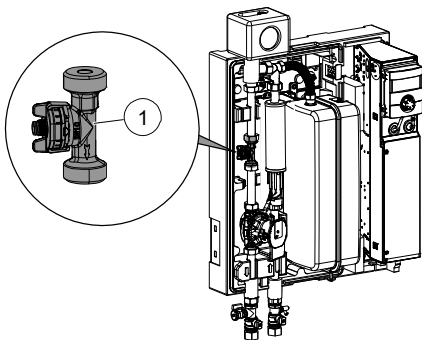

The volumetric flow meter / heat meter measures flow and temperature difference in the charging circuit. The measuring ranges are set in the heating and heat pump controller. Measured values can be read out on the control panel display.

→ Operating manual of the heating and heat pump controller

14 Commissioning

→ Operating manual of the heating and heat pump controller

→ Operating manual of the heat pump

15 Maintenance



NOTE

We recommend that you sign a maintenance agreement with an accredited heating company.

15.1 Maintenance as required

- ▶ The components of the heating circuit (valves, expansion vessels, circulating pumps, filters, dirt traps) should be inspected or cleaned as needed, at the very least annually, by qualified personnel (heating or cooling system engineers).

15.2 Yearly maintenance

- ▶ Determine the quality of the heating water by analysis. In the event of deviations from the specifications, take suitable measures without delay.
- ▶ Check all installed dirt traps for dirt and clean them if necessary.



16 Faults

- ▶ Read out the cause of the fault via the diagnostics program of the heating and heat pump controller.
- ▶ Contact the local partner of the manufacturer or the factory's customer service. Have the fault message and unit number (→ "Nameplate", page 7) to hand.

16.1 Unlock safety temperature limiter

A safety temperature limiter for the electric heating element is mounted on the electrical switch box. If the heat pump fails or there is air in the system:

- ▶ Check whether the reset button (①) of the safety temperature limiter has tripped.
- ▶ If the reset button (①) has tripped, press it again.

Example HV 4:

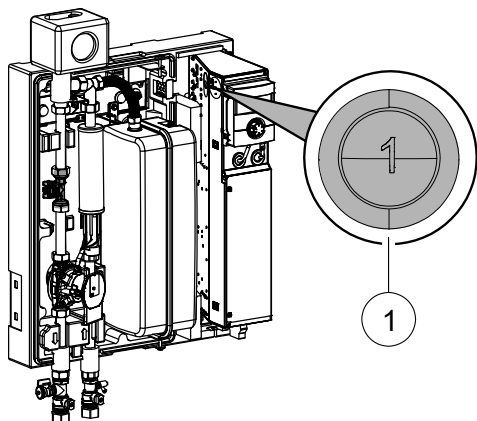

- ▶ If the safety temperature limiter trips again, contact the local partner of the manufacturer or the factory's customer service.

17 Dismantling and disposal

17.1 Dismantling

- ▶ Separate components by their materials.

17.2 Disposal and recycling

- ▶ Recycle or ensure proper disposal of unit components and packaging materials in accordance with local regulations.

17.2.1 Buffer (standby) battery

1. Use a screwdriver to push out the buffer battery on the processor board of the control panel.
2. Dispose of the buffer battery (type: CR2032, lithium) in accordance with local regulations.



HV 4

Technical data / Scope of supply

Accessories for heat pump type				HV 4
Air/water output-controlled	Indoor and outdoor installation	4 kW 8 kW 12 kW	• yes – no	• – –
Air/water Dual output-controlled	Outdoor installation	5 kW 7 kW 9 kW	• yes – no	– – –
Air/water output-controlled	Outdoor installation	5 kW 7 kW	• yes – no	– –
Air/water	Outdoor installation	14 kW 18 kW	• yes – no	– –
Air/water Dual	Outdoor installation	5 kW 7 kW 9 kW	• yes – no	– – –
Air/water Dual RX	Outdoor installation	5 kW 7 kW	• yes – no	– –
Installation location				
Room temperature		min. max.	°C	5 35
Relative humidity maximum (non-condensing)			%	60
Sound				
Sound pressure level at 1 m distance	inside		dB(A)	36
Sound power level	inside		dB(A)	44
Heating circuit				
Flow rate: minimum maximum (see heat pump for pipe dimensioning)			l/h l/h	170 1200
Free pressing Pressure loss Flow rate			bar bar l/h	0.4 – 1200
Max. allowable operating pressure			bar	3
Circulation pump control range	min. max.		l/h	170 1200
General unit data				
Total weight			kg	25
Weight of individual components			kg kg kg	– – –
Electrics				
Voltage code all-pole fuse protection for heat pump **)*)	1 phase		... A	1~N/PE/230V/50Hz C10
Voltage code all-pole fuse protection for heat pump **)*)	3 phases		... A	– –
Voltage code Control voltage fuse protection **)			... A	1~N/PE/230V/50Hz B10
Voltage code Electric heating element fuse protection **)	1 phase		... A	1~N/PE/230V/50Hz B32
Voltage code Electric heating element fuse protection **)	3 phases		... A	3~N/PE/400V/50Hz B16
Degree of protection			IP	10B
Zmax			Ω	–
Residual current circuit breaker	if required		type	B
Electric heating element output	3 2 1 phase		kW kW kW	6 4 2
Circulation pump power consumption, heating circuit	min. max.		W	3 43
Other unit information				
Safety valve Heating circuit Response pressure		included in scope of supply: • yes – no bar		• 3
Buffer tank Volume		included in scope of supply: • yes – no l		– –
Diaphragm expansion vessel Heating circuit Volume Prepressure		incl. in scope of supply: • yes – no l bar		• 12 1.5
Overflow valve Changeover valve, heating - domestic hot water		integrated: • yes – no		– –
Vibration decoupling, Heating circuit Heat source		included in scope of supply or integrated: • yes – no		–
Controller Heat quantity recording Extension board		included in scope of supply or integrated: • yes – no		• • –
*) compressor only, **) note local regulations Index: m-Hyd				813649a



Technical data / Scope of supply

HV 6H / HV 9H

Accessories for heat pump type				HV 6H	HV 9H
Air/water output-controlled	Indoor and outdoor installation	4 kW 8 kW 12 kW	• yes – no	– – –	– – –
Air/water dual output-controlled	Outdoor installation	5 kW 8 kW 9 kW	• yes – no	–	–
Air/water output-controlled	Outdoor installation	5 kW 7 kW	• yes – no	• •	• •
Air/water	Outdoor installation	14 kW 18 kW	• yes – no	– –	– –
Air/water Dual	Outdoor installation	5 kW 7 kW 9 kW	• yes – no	– – –	– – –
Air/water Dual RX	Outdoor installation	5 kW 7 kW	• yes – no	– –	– –
Installation location					
Room temperature		min. max.	°C	5 35	5 35
Relative humidity maximum (non-condensing)			%	60	60
Sound					
Sound pressure level at 1 m distance		inside	dB(A)	36	36
Sound power level		inside	dB(A)	44	44
Heating circuit					
Flow rate: minimum maximum (see heat pump for pipe dimensioning)			l/h l/h	500 2500	500 2500
Free pressing Pressure loss Flow rate			bar bar l/h	0.72 – 1200	0.72 – 1200
Max. allowable operating pressure			bar	3	3
Circulation pump control range		min. max.	l/h	500 2500	500 2500
General unit data					
Total weight			kg	25	40
Weight of individual components			kg kg kg	– – –	– – –
Electrics					
Voltage code all-pole fuse protection for heat pump *)**)		1 phase	... A	1~N/PE/230V/50Hz B16	1~N/PE/230V/50Hz B16
Voltage code all-pole fuse protection for heat pump *)**)		3 phases	... A	– –	– –
Voltage code Control voltage fuse protection **)			... A	1~N/PE/230V/50Hz B10	1~N/PE/230V/50Hz B10
Voltage code Electric heating element fuse protection **)		1 phase	... A	1~N/PE/230V/50Hz B32	1~N/PE/230V/50Hz B40
Voltage code Electric heating element fuse protection **)		3 phases	... A	3~N/PE/400V/50Hz B16	3~N/PE/400V/50Hz B16
Degree of protection			IP	10B	20
Zmax			Ω	–	–
Residual current circuit breaker		if required	type	B	B
Electric heating element output		3 2 1 phase	kW kW kW	6 4 2	9 6 3
Circulation pump power consumption, heating circuit		min. max.	W	2 74	2 74
Other unit information					
Safety valve Heating circuit Response pressure		included in scope of supply: • yes – no bar		• 3	• 3
Buffer tank Volume		included in scope of supply: • yes – no l		– –	– –
Diaphragm expansion vessel Heating circuit Volume Prepressure		incl. in scope of supply: • yes – no l bar		• 12 1.5	• 18 1.5
Overflow valve Changeover valve, heating - domestic hot water		integrated: • yes – no		– –	– –
Vibration decoupling, Heating circuit Heat source		included in scope of supply or integrated: • yes – no		–	–
Controller Heat quantity recording Extension board		included in scope of supply or integrated: • yes – no		• • –	• • –
				813657	813658

*) compressor only, **) note local regulations | Index: o



HV 4 / HV 6H / HV 9H

Free pressing

HV 4

HV 6H

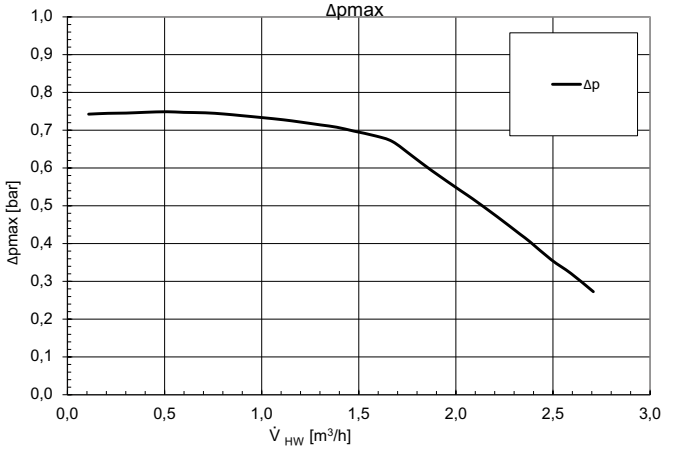
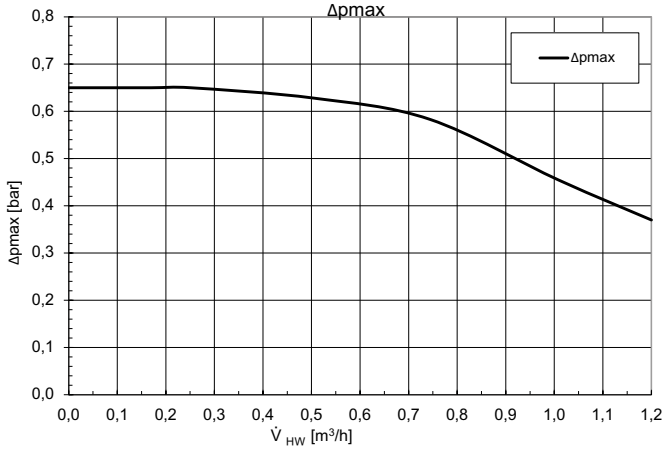

823329

HV 9H

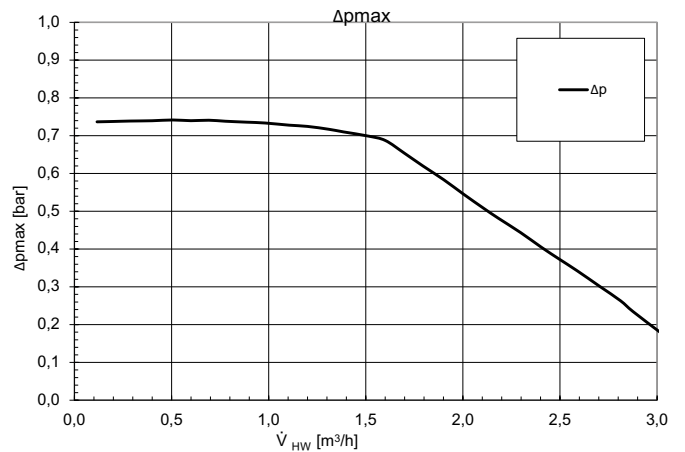

Key: UK823329

\dot{V}_{HW}	Volumetric flow of hot water
Δp_{max}	Maximum free pressing



Dimensioned drawings

HV 4 / HV 6H

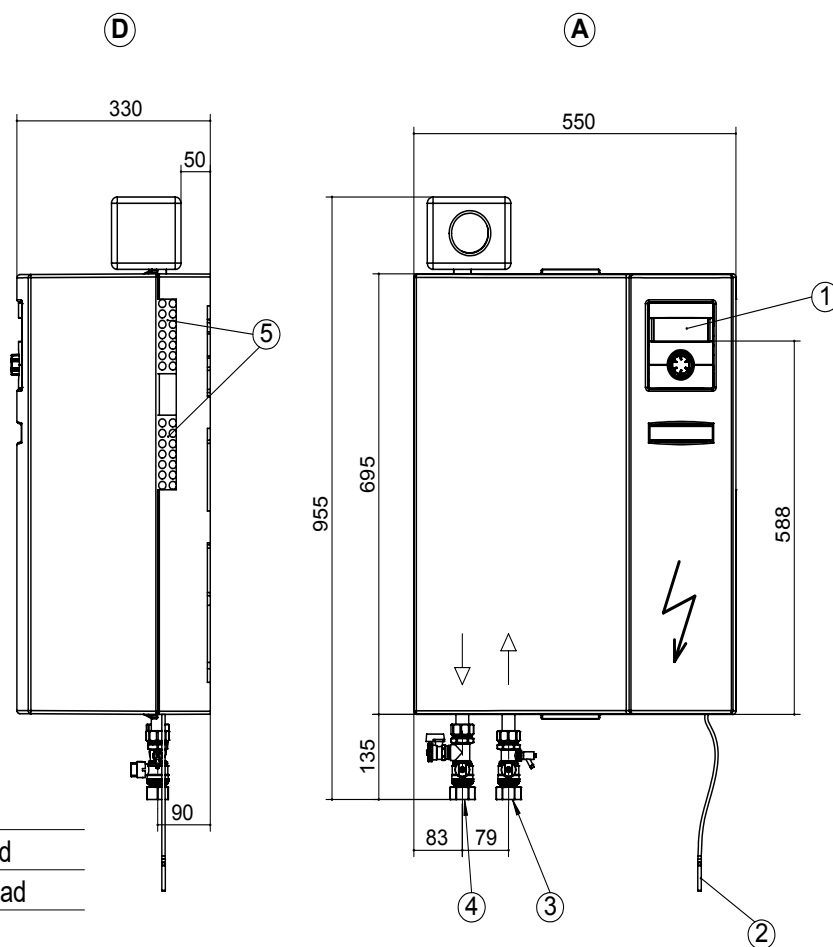

Key: UK819396

All dimensions in mm.

Pos.	Name
A	Front view
D	Side view from right
1	Control panel
2	Return flow sensor approx. 5.5m from unit
3	Heating water inlet (supply) Rp 1" internal thread
4	Heating water outlet (supply) Rp 1" internal thread
5	Penetrations for electric/sensor cables

The hydraulic module is installed in the heating flow!

Drill pattern

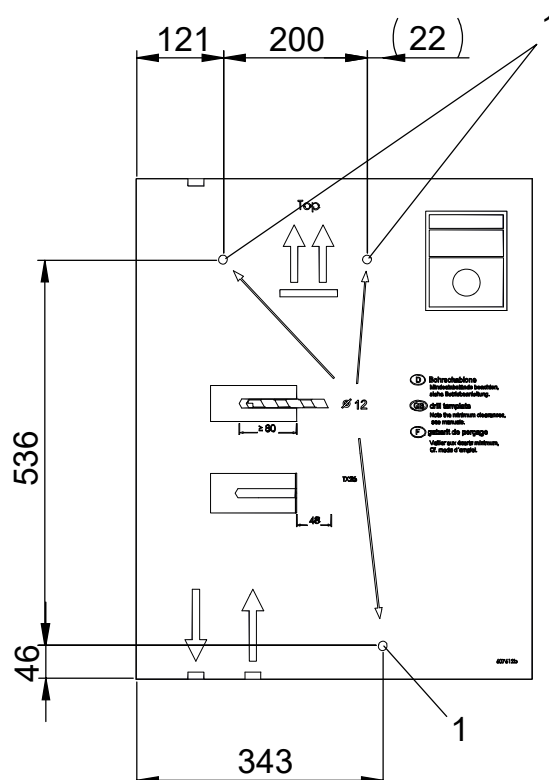

Key: UK819403a

All dimensions in mm.

Pos.	Name
1	Drill hole Ø12 for plug (incl. accessory package)



HV 9H

Dimensioned drawings

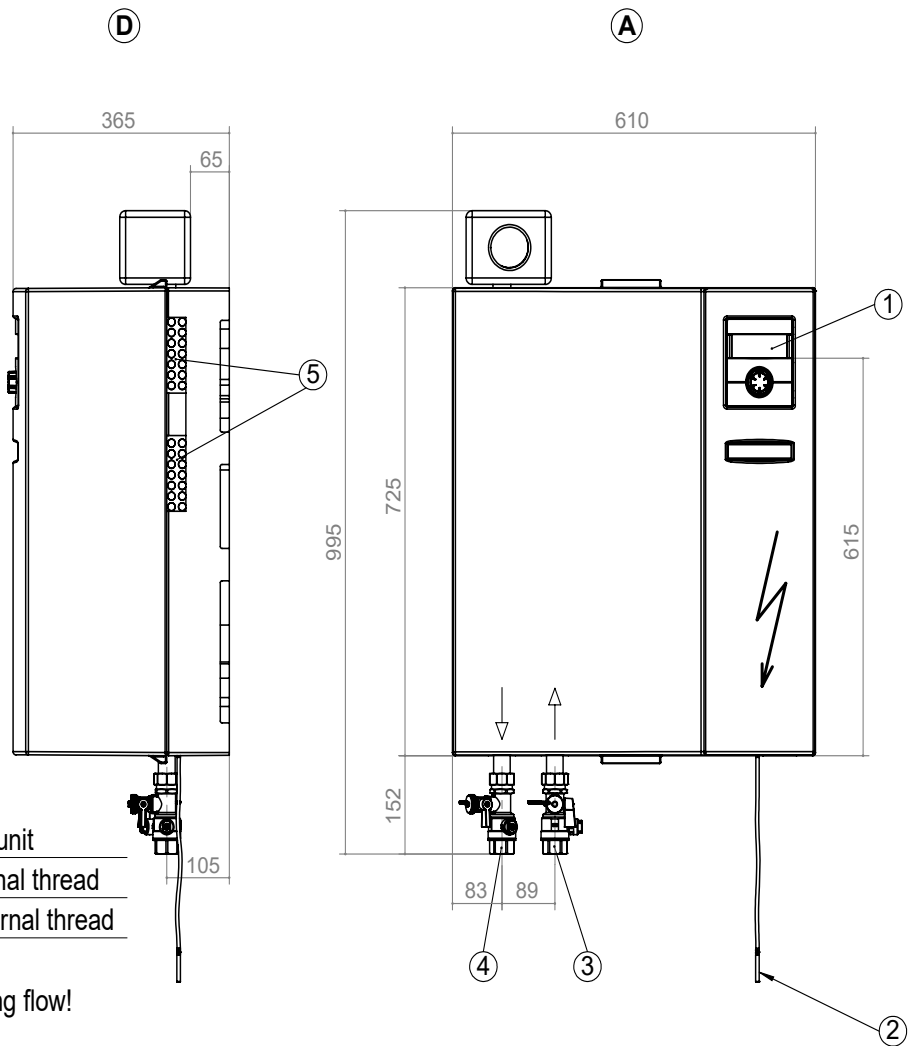

Keys: UK819487

All dimensions in mm.

Pos.	Name
A	Front view
D	Side view from right
1	Control panel
2	Return flow sensor approx. 5.5m from unit
3	Heating water inlet (supply) Rp 1" internal thread
4	Heating water outlet (supply) Rp 1" internal thread
5	Penetrations for electric/sensor cables

The hydraulic module is installed in the heating flow!

Drill pattern

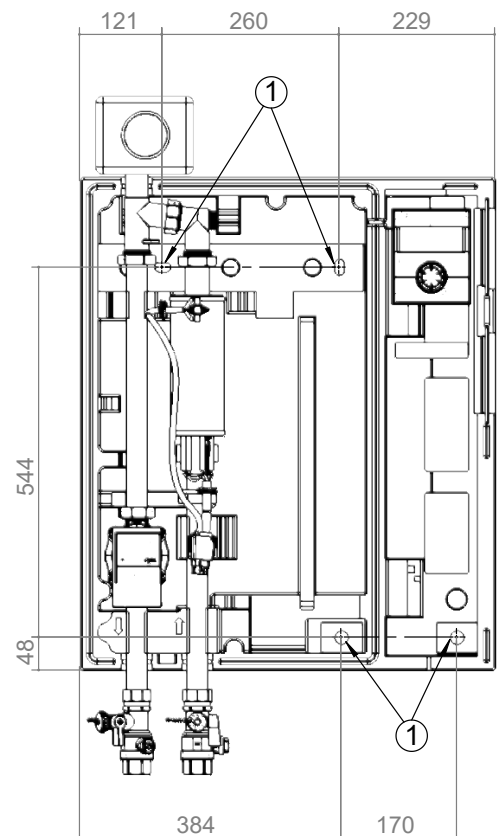

Keys: UK819493

All dimensions in mm. Spacing for drill pattern.

Pos.	Name
1	Drill hole Ø12 for plug (incl. accessory package)



Installation plans

HV 4 / HV 6H

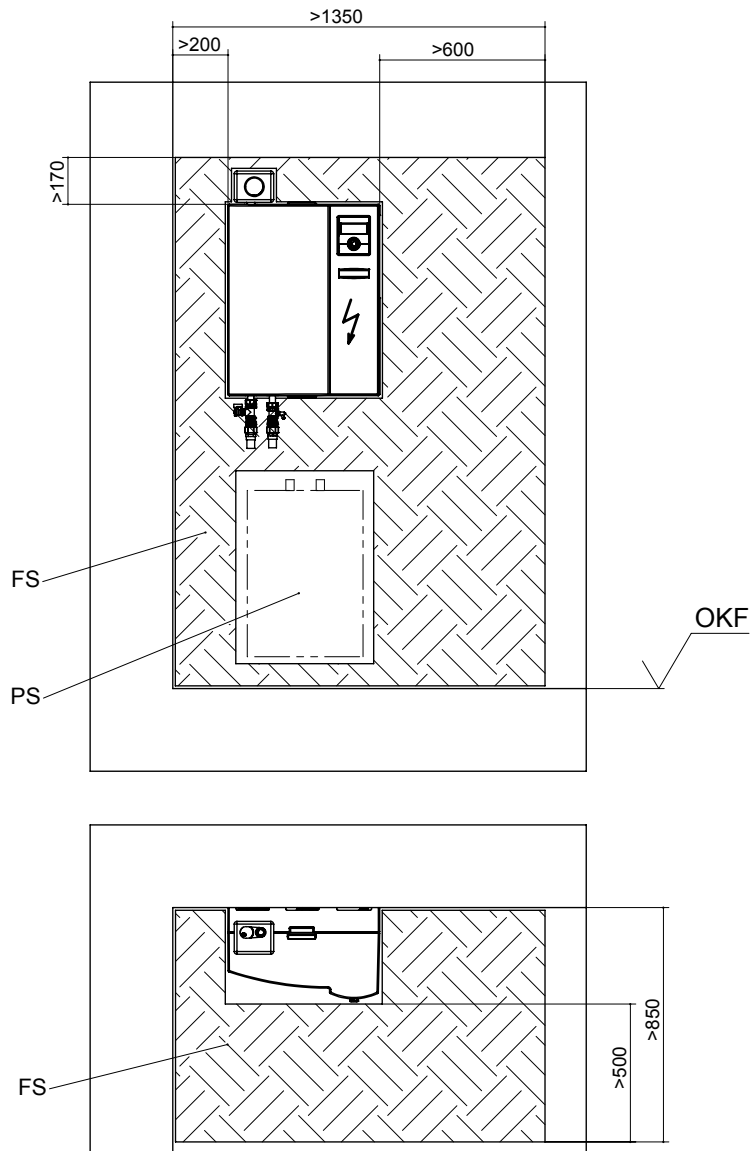

HV 9H

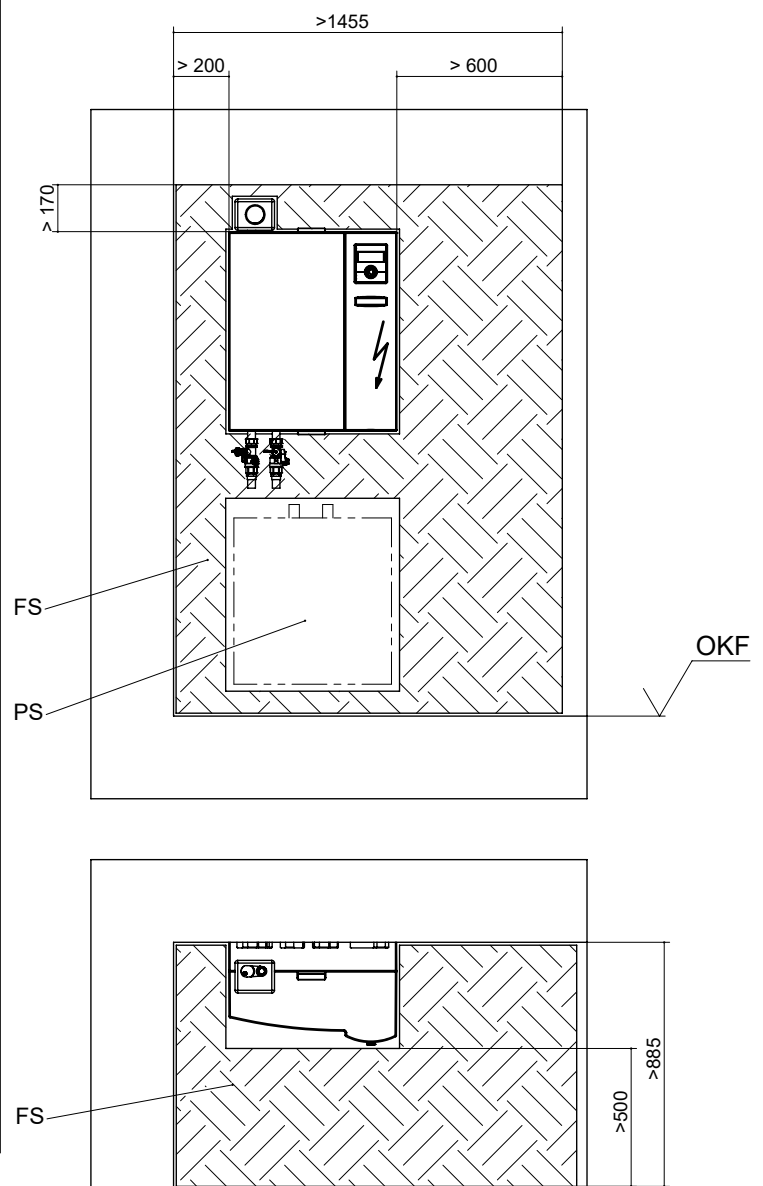

Key: UK819398

All dimensions in mm.

Pos.	Bezeichnung
FS	Free space for service purposes
OKF	Top edge of finished floor
PS	Free space for wall-hanging buffer tank possible

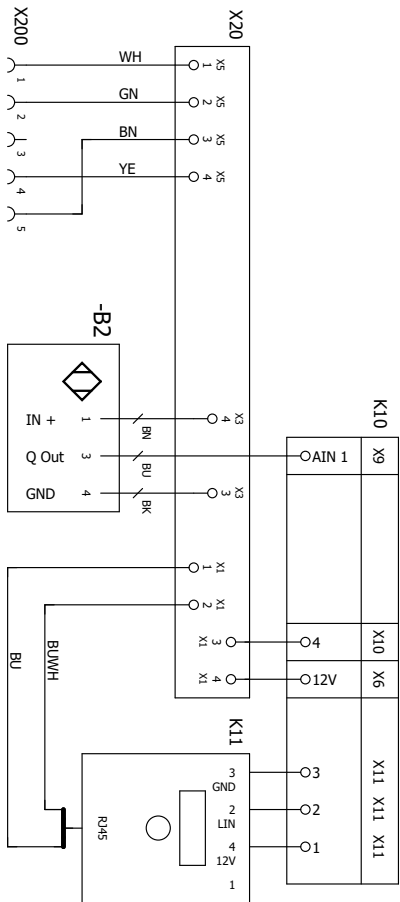
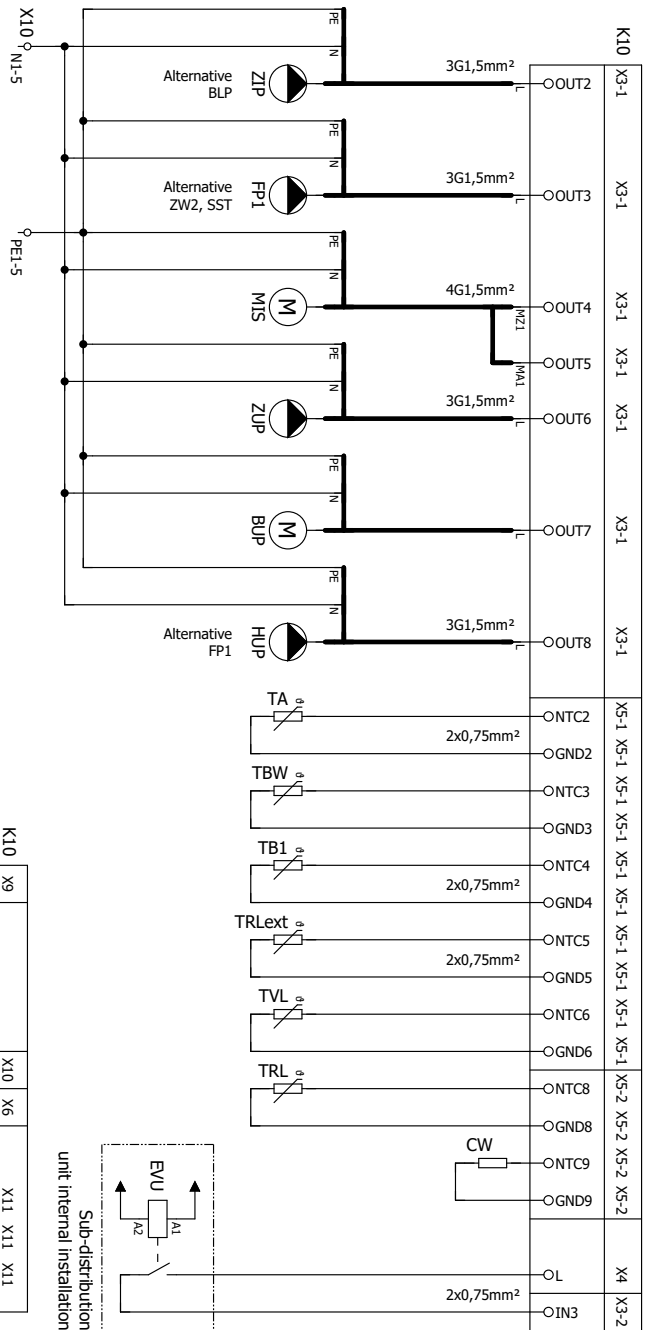
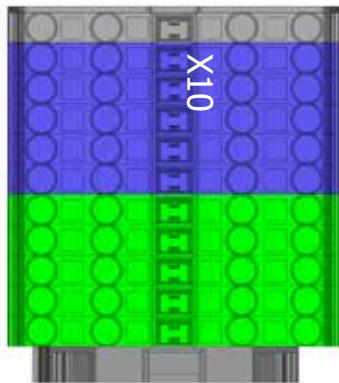
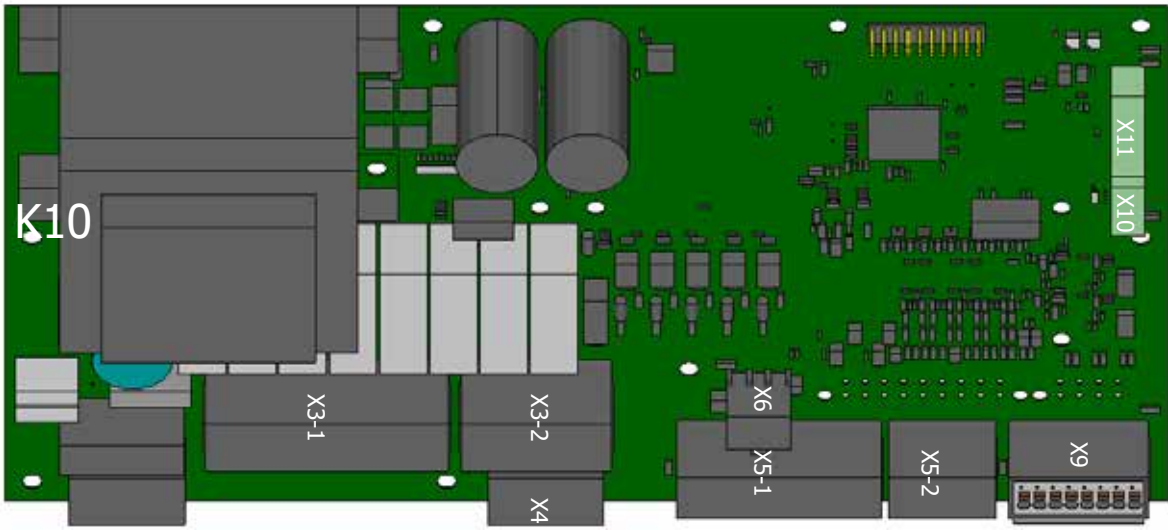

WARNING

The cable cross-sections shown are only intended as a guideline for the electrician! They must be adapted to the regional regulations and the conditions of use (e.g. cable length, current carrying capacity, ambient temperature, type of installation)!

UK
831248



HV 4 / HV 6H

Terminal diagram 2/2

UK 831248

Equipment	Description	Wired
PEX	Party external	
TA	Outdoor temperature sensor	
TBW	Domestic hot water temperature sensor / domestic hot water thermostat	
TB1	Temperature sensor, mixing circuit 1	
TRLext.	Temperature sensor, external return	
TVL	Temperature sensor supply	
TRL	Temperature sensor, return	
CW	Coding resistor	
STB / ZWE	Safety temperature limiter / additional heating generator	
EVU / SG 1	Block by power supply company (jumper if no blocking time) / Smart Grid control 1	
SG 2	Smart Grid control 2	
ZWE1	Additional heating generator 1	
ZIP / KS / BLP	DHW circulation pump / cooling signal / domestic hot water charge pump	
FP 1 / ZWE 2 / SST	Mixing circuit 1 circulation pump	
MIS (MZ1)	Mixing circuit 1 closed (discharge mixer / cooling mixer / charge mixer)	
MIS (MA1)	Mixing circuit 1 open (discharge mixer / cooling mixer / charge mixer)	
ZUP	Additional (feeder) circulation pump	
BLP	Domestic hot water circulation pump / Domestic hot water switching valve	
HUP	Heating circuit circulation pump	
VBO	Fan / Brine circulation pump / Well circulation pump	
B2	Volumetric flow meter	
K10	Controller circuit board; Caution: I max = 6.3A/230VAC	
K11	Control panel	
X10	Control voltage feed	
X20	MODBUS circuit board	
X200	MODBUS	

Refer to protection notice ISO 16016.



HV 9H

Terminal diagram 1/2

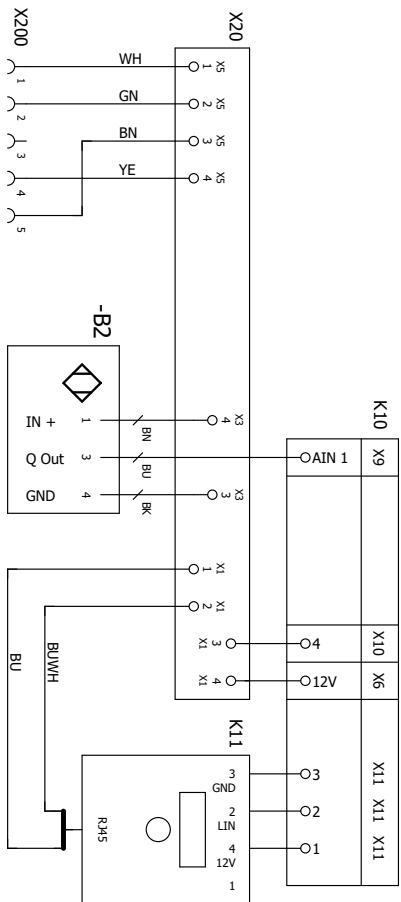
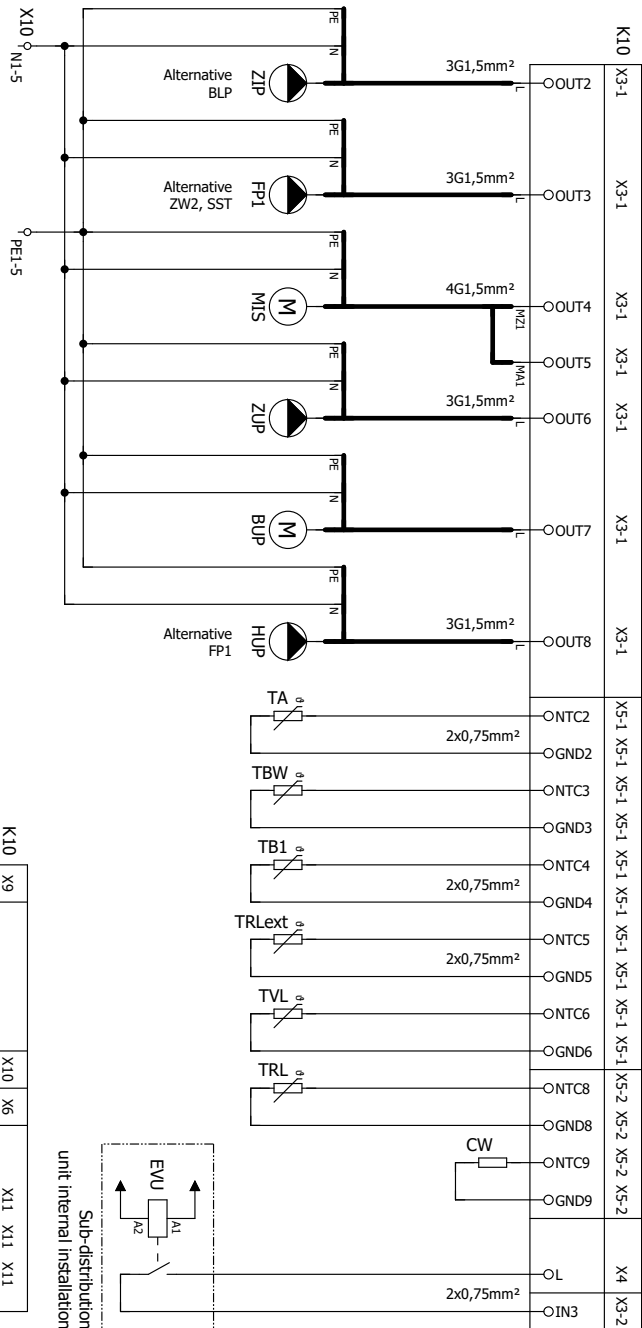
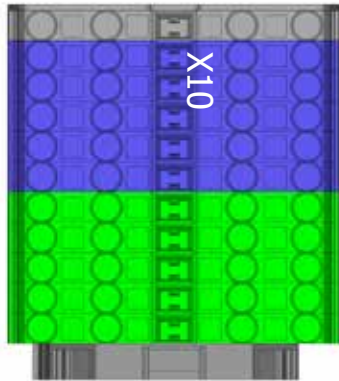
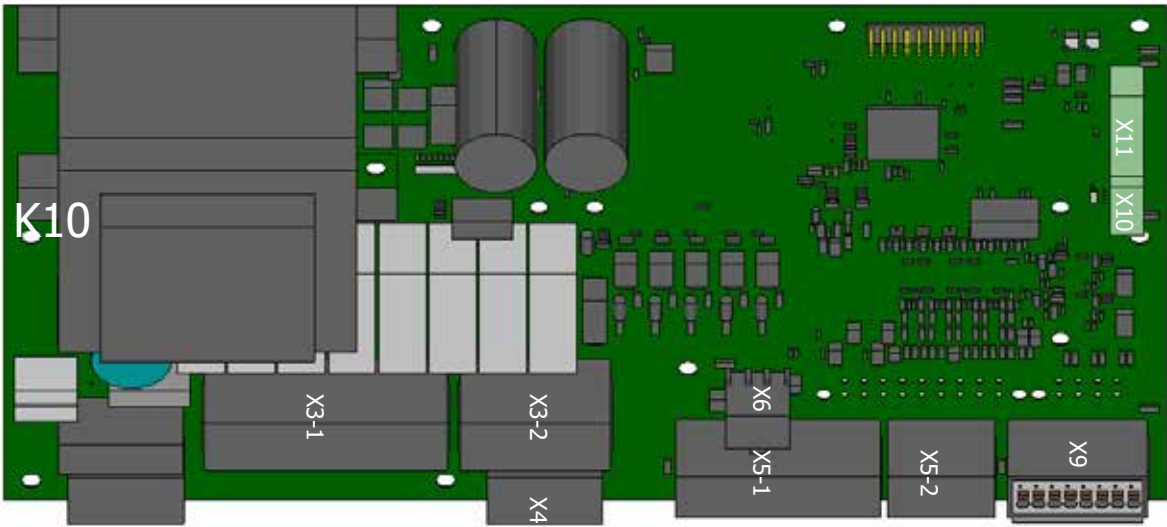

WARNING

The cable cross-sections shown are only intended as a guideline for the electrician! They must be adapted to the regional regulations and the conditions of use (e.g. cable length, current carrying capacity, ambient temperature, type of installation)!

UK
831250

Refer to protection notice ISO 16016.



Terminal diagram 2/2

UK 831250

Equipment	Description	Wired
PEX	Party external	
TA	Outdoor temperature sensor	
TBW	Domestic hot water temperature sensor / domestic hot water thermostat	
TB1	Temperature sensor, mixing circuit 1	
TRleft.	Temperature sensor, external return	
TVL	Temperature sensor supply	X
TRL	Temperature sensor, return	X
CW	Coding resistor	X
STB / ZWE	Safety temperature limiter / additional heating generator	
EVU / SG 1	Block by power supply company (jumper if no blocking time) / Smart Grid control 1	
SG 2	Smart Grid control 2	
ZWE1	Additional heating generator 1	
ZIP / KS / BLP	DHW circulation pump / cooling signal / domestic hot water charge pump	X
FP 1 / ZWE 2 / SST	Mixing circuit 1 circulation pump	
MIS (MZ1)	Mixing circuit 1 closed (discharge mixer / cooling mixer / charge mixer)	
MIS (MA1)	Mixing circuit 1 open (discharge mixer / cooling mixer / charge mixer)	
ZUP	Additional (feeder) circulation pump	
BLP	Domestic hot water circulation pump / Domestic hot water switching valve	
HUP	Heating circuit circulation pump	X
VBO	Fan / Brine circulation pump / Well circulation pump	
B2	Volumetric flow meter	X
K10	Controller circuit board; Caution: I max = 6.3A/230VAC	X
K11	Control panel	X
X10	Control voltage feed	X
X20	MODBUS circuit board	X
X200	MODBUS	X

Refer to protection notice ISO 16016.



HV ...

Terminal diagram, mains connection heat pump 1~230V + electric heating element 3~400V

0	1	2	3	4	5	6	7	8	9
---	---	---	---	---	---	---	---	---	---

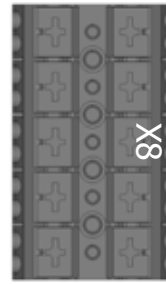

1x230V 50Hz / N / PE
Power supply compressor

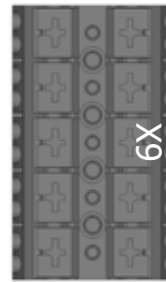
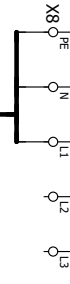

3x400V 50Hz / N / PE
Power supply electric heating element

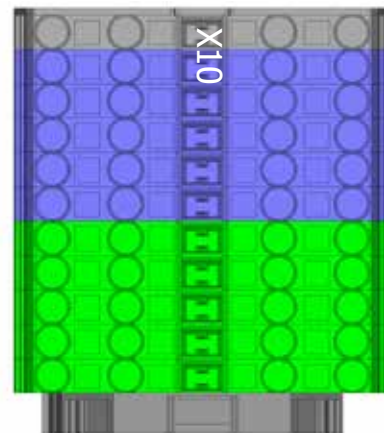
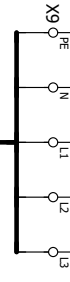

1x230V 50Hz / N / PE
Power supply control

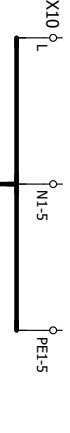

Sub-distribution unit: Internal installation
Please refer to the technical data for fuse protection!
UK
831222a

Equipment	Description
FKU1	Circuit breaker compressor
FKU2	Circuit breaker electric heating element
FKU3	Circuit breaker control
X8	Terminal for compressor
X9	Terminal for electric heating element
X10	Terminal for control



Terminal diagram, mains connection heat pump 1~230V + electric heating element 1~230V

0	1	2	3	4	5	6	7	8	9
---	---	---	---	---	---	---	---	---	---

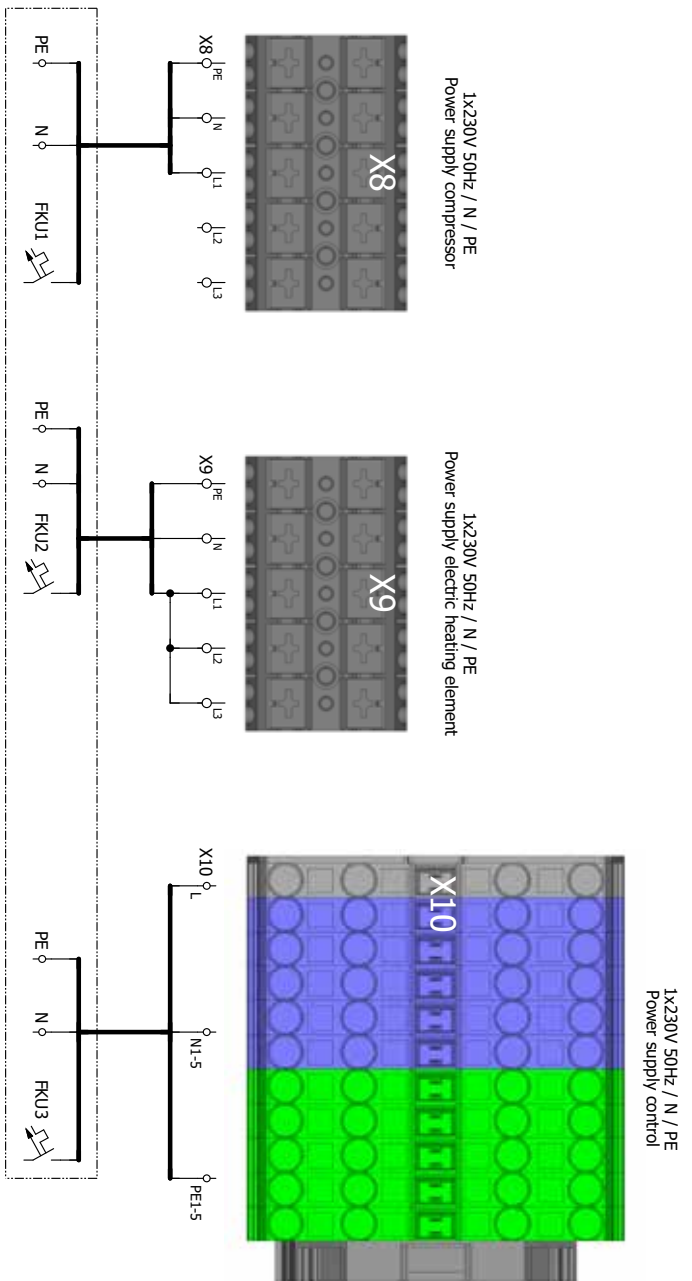

Equipment	Description
FKU1	Circuit breaker compressor
FKU2	Circuit breaker electric heating element
FKU3	Circuit breaker control
X8	Terminal for compressor
X9	Terminal for electric heating element
X10	Terminal for control

Refer to protection notice ISO 16016.

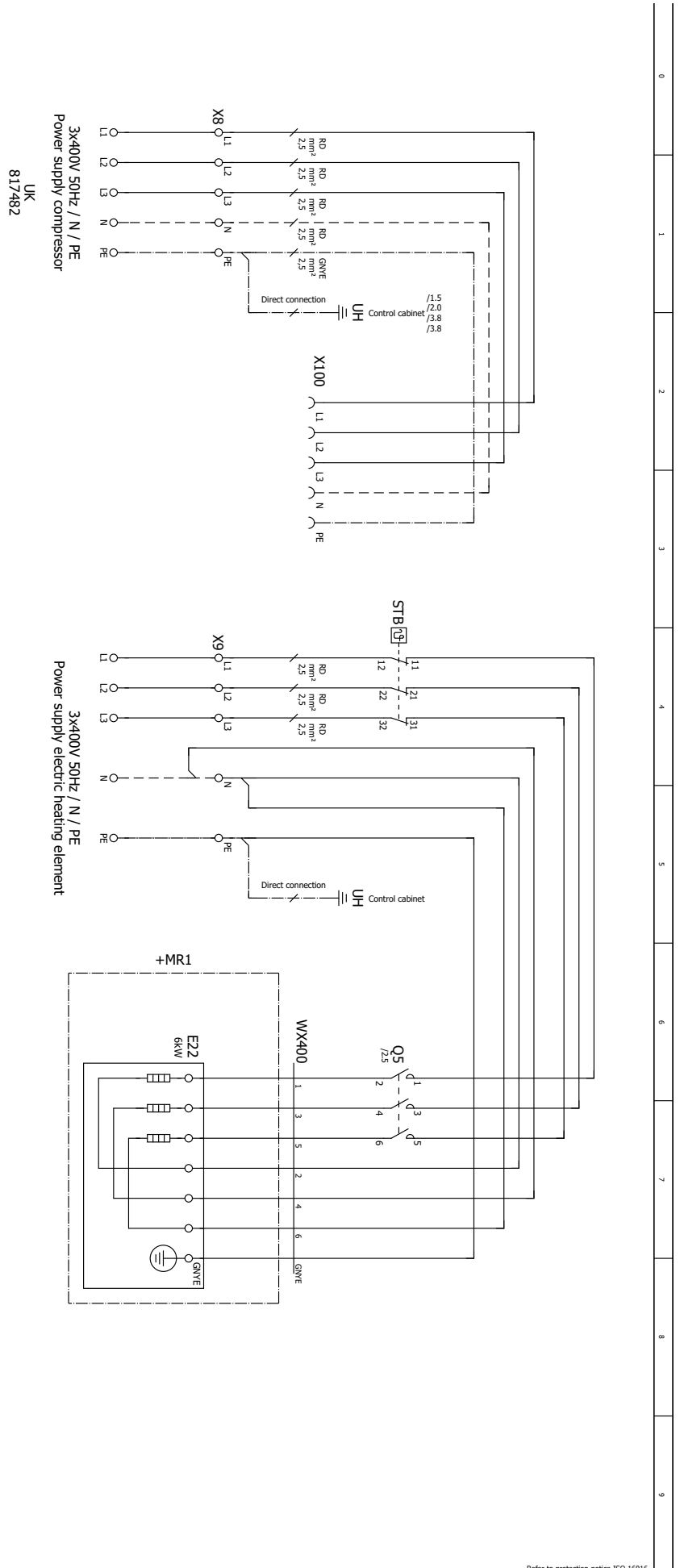

0	1	2	3	4	5	6	7	8	9
---	---	---	---	---	---	---	---	---	---

Refer to protection notice ISO 16016.



0
1
2
3
4
5
6
7
8
9

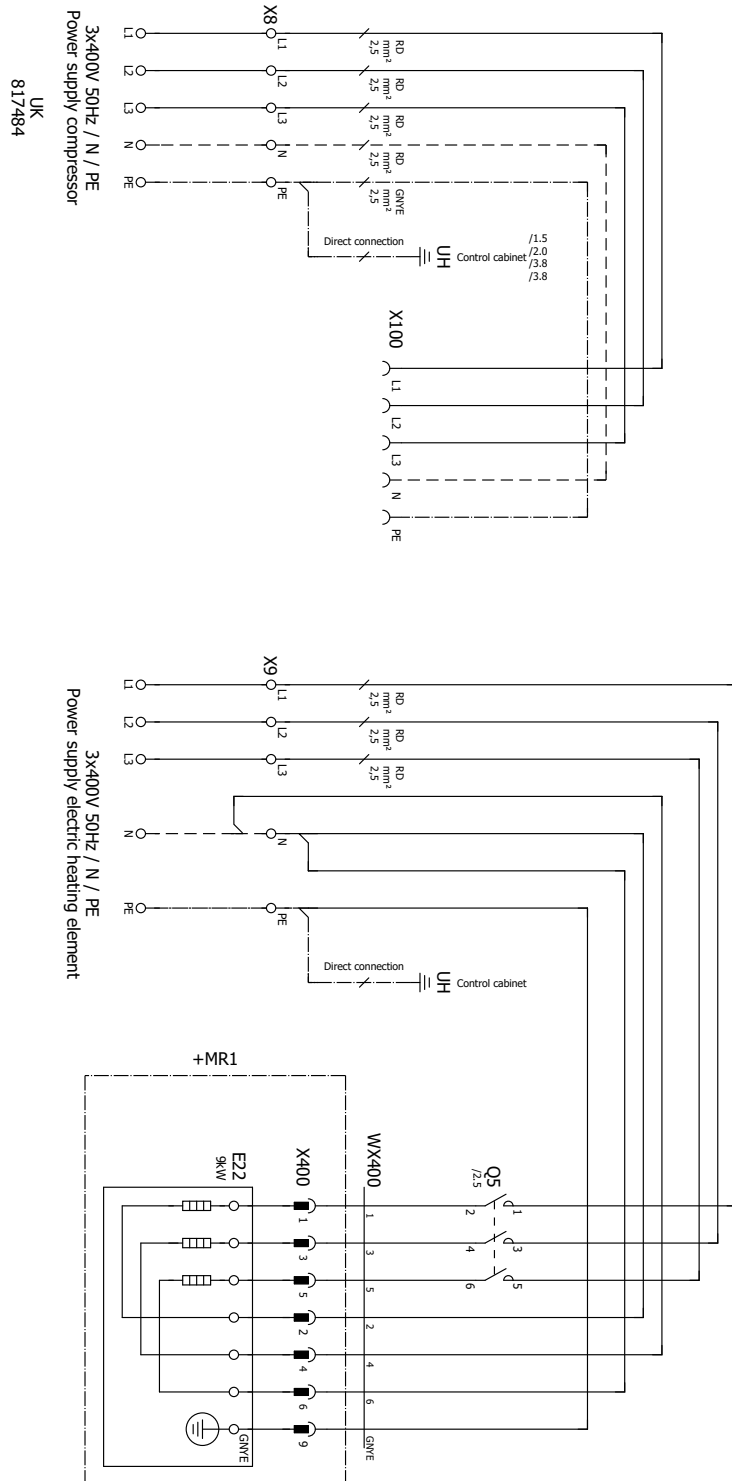

Refer to restriction notice ISO 16016



Circuit diagram 2/4

HV 9H

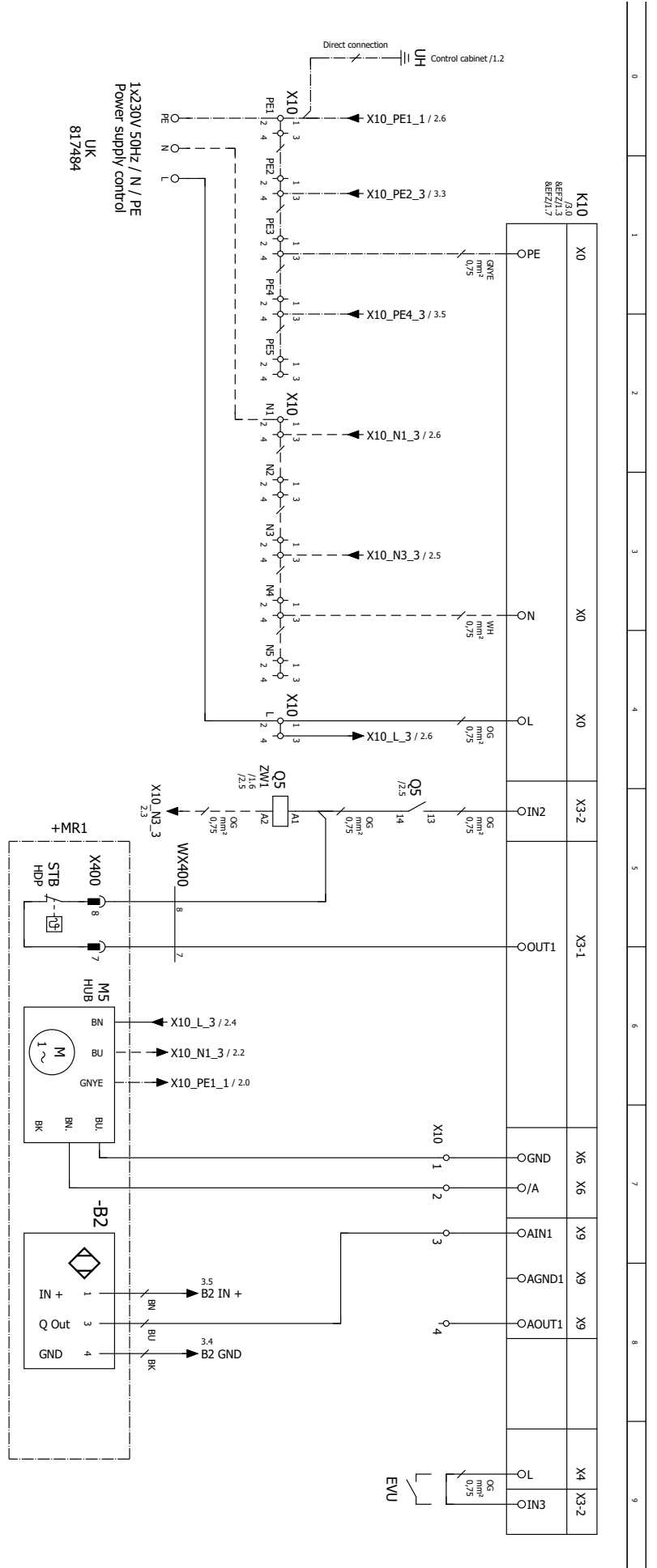

Refer to production notice ISO 15016.

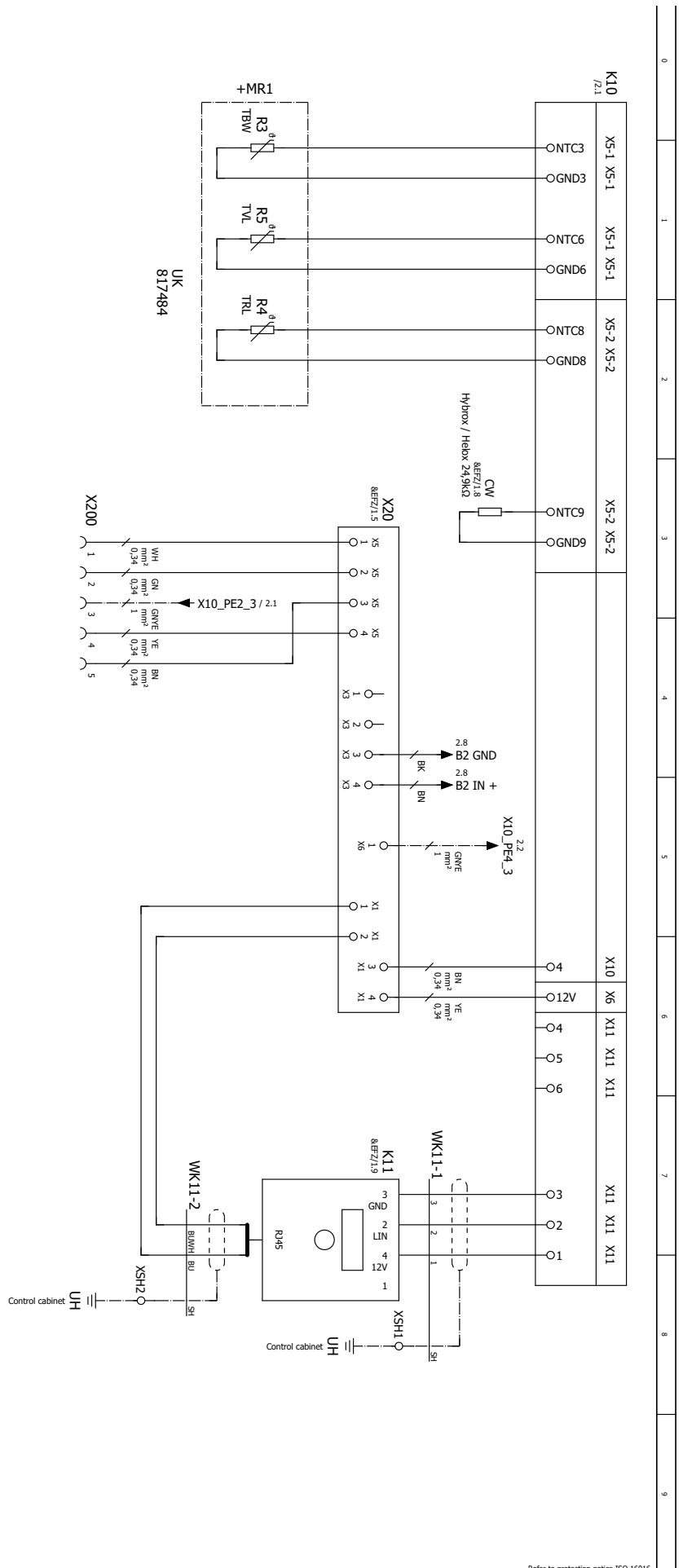

Refer to protection notice ISO 16016.



Circuit diagram 4/4

817484

Equipment	Description
B2	Volumetric flow meter
E22	Electric heating element
EVU	Energy supplier contact; closed on release; bridge if no blocking interval
K10	Controller board; Attention: I-max = 6,3A/230VAC
K11	Control unit
M5	Heating pump
Q5	Contact for Electric heating element
R3	Domestic hot water temperature sensor
R4	Return sensor
R5	Flow sensor
R9	Coding resistance; Hybrox / Helox 24,9KOhm
STB	Temperature shutdown Electric heating element
WK11-1	Connection cable control unit
WK11-2	Connection cable control unit
WX400	Connection Electric heating element
X8	Power supply compressor
X9	Power supply electric heating element
X10	Power supply control
X20	Terminal board, Modbus
X100	Power supply WP
X200	MOD-BUS
X300	Power supply controller 230V
X400	Power supply electric heating element
XSE	Sensorcard
XSH	Shield clamp Control unit
+MR1	Machine room

Refer to protection notice ISO 16016.





an ideal tomorrow

The logo for ait Heat Pumps is located in the top right corner. It features the lowercase letters 'ait' in a white, sans-serif font on a dark blue square background. A small blue square is positioned above the 'i'. Below the 'ait' text, the words 'HEAT PUMPS' are written in a smaller, white, uppercase, sans-serif font.

ait-deutschland GmbH
Industriestraße 3
95359 Kasendorf
Germany

T +49 9228 / 99 06 0
F +49 9228 / 99 06 149
E info@ait-deutschland.eu

www.aitgroup.com

Member of NIBE Group.